

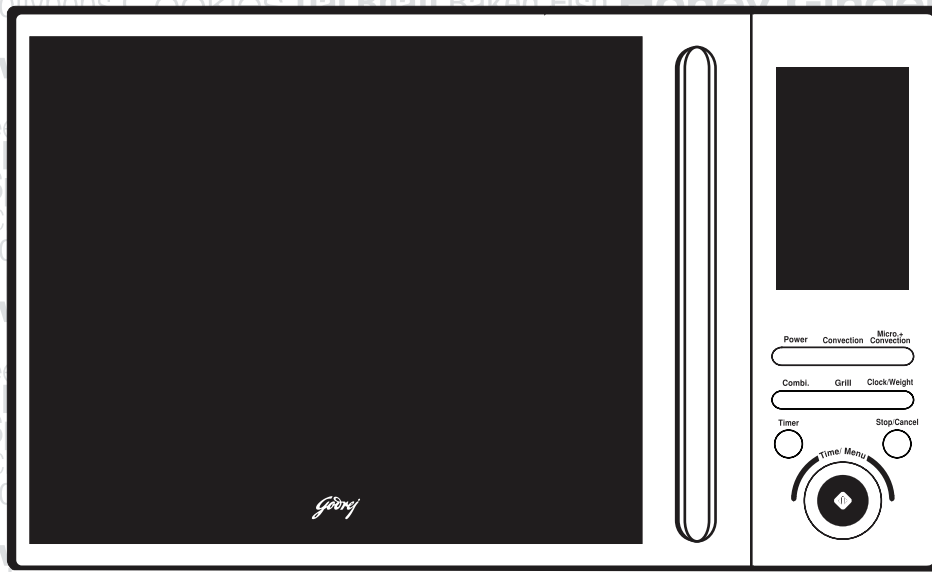

MODEL: GMX 25CA2 FIZ
CONVECTION MICROWAVE OVEN



Please read these instructions carefully before installing and operating the oven.

Record in the space below the SERIAL NO. found on the nameplate on your oven and retain this information for future reference.

SERIAL NO:

The above image is for representative purpose, actual image of the product may vary

Thank you for purchasing Godrej Microwave Oven

Please record the model number and serial number of this unit for future reference.

Staple your receipt here for proof of purchase.

Model No: _____

Serial No: _____

Dealer: _____

Dealer Phone No: _____

SPECIFICATIONS

Power Consumption:	230V/50Hz, 1400W(Microwave)
	1000W(Grill)
	1950W(Convection)
Rated Microwave Output:	900W
Operation Frequency:	2450MHz
Product Dimensions:	28.1cm(H)×48.3cm(W)×41.4cm(D)
Oven Capacity:	25Litres
Cooking Uniformity:	Turntable System
Net Weight:	Approx.16.0kg

TABLE OF CONTENT

IMPORTANT SAFETY INSTRUCTIONS	3
UTENSIL GUIDE	5
INSTALLATION INFORMATION	5
GROUNDING INSTRUCTIONS	6
ELECTRICAL REQUIREMENTS	6
RADIO INTERFERENCE	6
EXTENSION CORD INFORMATION	6
PART NAMES	6
CONTROL PANEL	7
OPERATION INSTRUCTIONS	8
INSTACOOK MENUS	12
CLEANING AND CARE	17
TROUBLESHOOTING	18
FAQs	19
WARRANTY	20

IMPORTANT SAFETY INSTRUCTIONS

READ CAREFULLY AND KEEP FOR FUTURE USE

Important Safety instructions

The Safety instructions mentioned below will tell you how to use your Microwave Oven without harming yourself and damaging your oven.

Warning – To reduce the risk of burns, electric shock, fire, injury to persons, or exposure to excessive microwave energy

- Read all the instructions before using your oven
- Do not allow children to use this oven without close supervision

Precautions to avoid possible exposure to excessive microwave energy:

- Do not attempt to operate this oven with the door open since open door operation can result in harmful exposure to microwave energy. It is important not to tamper with the safety interlocks.
 - Do not place any object between the microwave oven cavity and the door or allow soil or cleaner residue to accumulate on sealing surfaces
 - Do not operate the oven if it is damaged. It is particularly important that the oven door closes properly and that there is no damages to the:
 - Door (bent)
 - Hinges and latches (broken or loosened)
 - Door seals and sealing surfaces
 - It is hazardous for anyone other than properly qualified competent service personnel to repair, adjust or remove the cover which gives protection against exposure to microwave energy
- 1. Do not heat the following items in the microwave oven:** Whole eggs in the shell, water with oil or fat, sealed containers, or closed glass jars.

These items may explode.

- Do not cover or block any openings in the oven
- Use your oven only for the operations described in this manual
- Do not run the oven empty, without food in it
- Do not deep fry in your microwave oven
- Do not remove the turn table while using the microwave oven

- Do not make popcorn, peanuts and suji roast in plastic utensil. Use only microwaveable glass utensil.
- Only use utensils suitable for use in microwave oven
 - Remove wire twist-ties and metal handles from paper or plastic containers/bags before placing them in the oven
 - The oven should be cleaned regularly and any food deposits should be removed. Failure to maintain the oven in a clean condition could lead to deterioration of the surface, and could adversely affect the life of the appliance and possibly result in a hazardous situation.
 - When the appliance is operated in the combination mode, children should only use the oven under adult supervision due to the temperatures generated.
 - To avoid a fire hazard do not severely overcook food. Severely overcooked foods can start a fire in the oven.
 - When heating food in plastic or paper containers, keep an eye on the oven due to the possibility of ignition.
 - If smoke is observed, switch off or unplug the appliance and keep the door closed in order to stifle any flames
 - Do not use the cavity for storage purposes. Do not leave paper products, cooking utensils, or food in the cavity when not in use.
 - Do not use this oven for commercial purposes. This appliances is intended to be used in household and similar application such as:
 - Staff Kitchen areas in shops, offices and other working environments;
 - Farm Houses;
 - By clients in hotels, motels and other residential environments;
 - Bed and breakfast type environments.
 - When cleaning the door and the surfaces that touch the door, use only mild, non-abrasive soaps or detergents and a sponge or soft cloth
 - Do not use corrosive chemicals or vapours, in this appliance. This type of oven is specifically designed to heat, cook, or dry food. It is not designed for industrial or laboratory use

13. Do not use or store this appliance outdoors. Do not use this product near water for example near a kitchen sink, in a wet basement, or near a swimming pool, and the likes.
14. Do not tamper with the built-in safety switches on the oven door. The oven has several built-in safety switches to make sure the power is off when the door is open.
15. If the supply cord is damaged, it must be replaced by the manufacturer, its service agent or similarly qualified persons in order to avoid a hazard
16. If your oven is dropped or damaged, have it thoroughly checked by a qualified service technician before using it again
17. The temperature of accessible surfaces may be high when the appliance is operating. Keep cord away from heated surface, and do not cover the oven.
18. Do not immerse the electrical cord or plug in water
19. Pierce food with heavy skin such as potatoes, whole squashes, apples, tomatoes, brinjals, mutton, chicken before cooking
20. Cooking utensils may become hot because of heat transferred from heated food. Potholders may be needed to handle the utensils. Utensils should be checked to ensure that they are suitable for use in microwave ovens.
21. The microwave oven shall not be placed in a cabinet
22. Liquids, such as water, coffee, or tea can be overheated beyond the boiling point without appearing to be boiling. Visible bubbling or boiling when the container is removed from the microwave oven is not always present. **THIS COULD RESULT IN VERY HOT LIQUIDS SUDDENLY BOILING OVER WHEN THE CONTAINER IS DISTURBED OR A SPOON OR OTHER UTENSIL IS INSERTED INTO THE LIQUID.**
23. To reduce the risk of injury to persons:
 - Do not overheat the liquid
 - Stir the liquid both before and halfway through heating it
 - While cooking or reheating in microwave mode, ensure the vent of the lid is kept open at all times or the lid is partially open
 - After heating, allow the container to stand in the microwave oven for a short time before removing the container
 - Use extreme care when inserting a spoon or other utensil into the container
24. The contents of feeding bottles and baby food jars shall be stirred or shaken and the temperature checked before consumption, in order to avoid burns
25. The appliances is not intended for use by persons (including children) with reduced physical, sensory or mental capabilities, or lack of experience and knowledge, unless they have been given supervision or instruction concerning use of the appliance by a person responsible for their safety
26. The rear surface of the appliance shall be placed against the wall
27. Microwave oven is intended for heating food and beverages. Drying of food or clothing and heating of warming pads, slippers, sponges, damp cloth and similar may lead to risk of injury, ignition or fire.
28. Microwave heating of beverages can result in delayed eruptive boiling, therefore care must be taken when handling the container.
29. Details for cleaning door seals, cavities and adjacent parts are given on page **CLEANING AND CARE**.
30. No temperature sensing probe to be inserted into the food placed inside the cavity of this oven by user, during switched ON state.
A temperature probe may be placed on the food once the food is taken outside the oven.
31. The microwave is intended to be used freestanding.

UTENSIL GUIDE

1. The ideal material for a microwave utensil is transparent to microwave, it allows energy to pass through the container and heat the food.
2. Microwave cannot penetrate metal, so metal utensils or dishes with metallic trim should not be used.
3. Do not use recycled paper products when microwave cooking, as they may contain small metal fragments which may cause sparks and/or fires.
4. Round /oval dishes rather than square/oblong ones are recommend, as food in corners tends to overcook.
5. Narrow strips of aluminum foil may be used to prevent overcooking of exposed areas. But be careful don't use too much and keep a distance of 1 inch (2.54cm) between foil and cavity.

The list below is a general guide to help you select the correct utensils.

Cookware	Microwave	Grill	Convection	Combination*
Heat-Resistant Glass	Yes	Yes	Yes	Yes
Non Heat-Resistant Glass	No	No	No	No
Heat-Resistant Ceramics	Yes	Yes	Yes	Yes
Microwave-Safe Plastic Dish	Yes	No	No	No
Kitchen Paper	Yes	No	No	No
Metal Tray	No	Yes	Yes	No
Metal Rack	No	Yes	Yes	No
Aluminum Foil & Foil Container	No	Yes	Yes	No

* Combination: applicable for both "microwave+grill", and "microwave+convection" cooking.

INSTALLATION INFORMATION

- 1) Select a level surface that provides enough open space for the intake and/or outlet vents

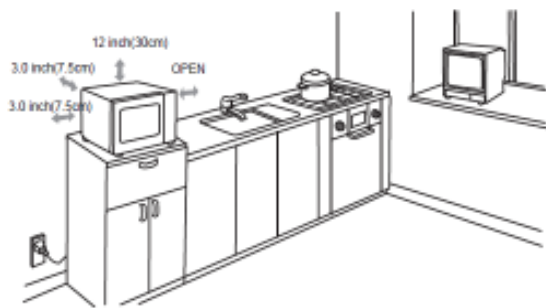

A minimum clearance of 7.5 cm is required between the oven and any adjacent walls. One side must be open.

- a) Leave a minimum clearance of 30 cm above the oven.
- b) Do not remove the legs from the bottom of the oven.

- c) Blocking the intake and/or outlet openings can damage the oven
- d) Place the oven as far away from radios and TV as possible

- 2) Plug your oven into a standard household outlet. Be sure the voltage and frequency is the same as the voltage and the frequency on the rating label at the back of the Microwave Oven.

- 3) Do not operate the oven without glass tray, roller support and shaft in their proper positions (applicable for microwave ovens with turn tables)

WARNING: Do not install oven over a range cooktop or other heat-producing appliance. If installed near or over a heat source, the oven could be damaged and the warranty would be void.

GROUNDING INSTRUCTIONS

This appliance must be grounded. This oven is equipped with a cord having a grounding wire with a grounding plug. It must be plugged into a wall receptacle that is properly installed and grounded. In the event of an electrical short circuit, grounding reduces risk of electric shock by providing an escape wire for the electric current. It is recommended that a separate circuit serving only the oven be provided. Using a high voltage is dangerous and may result in a fire or other accident causing oven damage.

WARNING Improper use of the grounding plug can result in a risk of electric shock.

Note:

- 1) If you have any questions about the grounding or electrical instructions, consult a qualified electrician or service person.
- 2) Neither the manufacturer nor the dealer can accept any liability for damage to the oven or personal injury resulting from failure to observe the electrical connection procedures.

The wires in this mains cable are colored in accordance with the following code:
Green and/or Yellow = EARTH, Blue and/or Black = NEUTRAL, Brown and/or Red = LIVE

ELECTRICAL REQUIREMENTS

The oven is designed to operate on a standard 230V/50Hz household outlet. Be sure the circuit is at least 15A or 20A and the

microwave oven is the **only appliance on the circuit**

RADIO INTERFERENCE

Operation of the microwave oven can cause interference to your radio, TV, or similar equipment.

When there is interference, it may be reduced or eliminated by taking the following measures:

1. Clean door and sealing surface of the oven.
2. Reorient the receiving antenna of radio or television.

3. Relocate the microwave oven with respect to the receiver.
4. Move the microwave oven away from the receiver.
5. Plug the microwave oven into a different outlet so that microwave oven and receiver are on different branch circuits.

EXTENSION CORD INFORMATION

1. A short power supply cord is provided to reduce the risks resulting from becoming entangled in or tripping over a longer cord

2. DO NOT USE AN EXTENTION CORD

PART NAMES

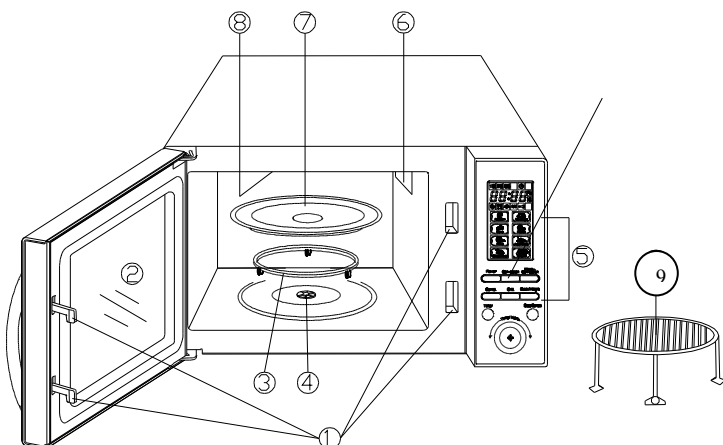

1. Door Safety Lock System
2. Oven Window
3. Roller Ring
4. Shaft
5. Control Panel
6. Oven Air Vent
7. Glass Tray
8. Heater
9. Metal Rack

CONTROL PANEL

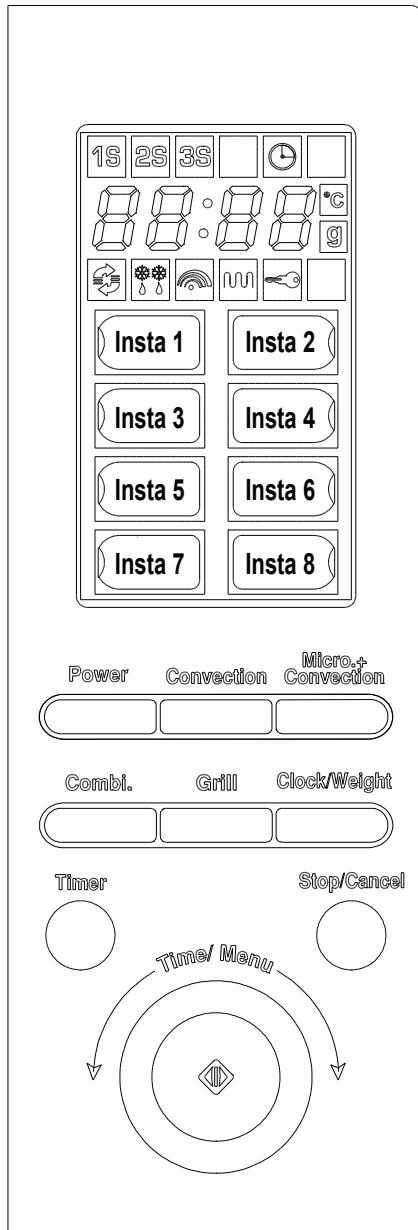

1. DISPLAY SCREEN

- Cooking time, power, indicators and present time are displayed.

2. POWER

- Press to select microwave power level.

3. GRILL

- Press to set a grill cooking program.

4. CONVECTION

- Press to program convection temperature.

5. COMBI. (MICRO.+GRILL)

- Press to select one of two combination cooking settings.

6. MICRO.+CONVECTION

- Press to select one of four combination cooking settings.

7. TIME/MENU (START/QUICK START)

- Rotate to set cooking time or select auto-menu.
- Press to start cooking program or set quick start cooking program.

8. CLOCK/WEIGHT

- Used to set clock time or enter food weight.

9. TIMER

- Used to set the oven timer.

10. STOP/CANCEL

- Touch to stop cooking program or clear all previous settings before cooking starts.

the above image is for representative purpose, actual image of the product may vary

OPERATION INSTRUCTIONS

Getting to Know your Microwave Oven

Each time a button is pressed, the microwave oven will beep to acknowledge each press of the button on the control panel. After a cooking program completes, the microwave oven will give a beep sound and a END will be displayed to indicate the completion of the cooking.

Setting the Clock

1. Press CLOCK/WEIGHT once.
2. Rotate TIME/MENU until the correct hour is displayed.
3. Press CLOCK/WEIGHT.
4. Rotate TIME/MENU until the correct minute is displayed.
5. Press CLOCK/WEIGHT to confirm.

NOTE: This is a 24-hour clock. You can check the clock time when cooking is in progress by pressing CLOCK/WEIGHT.

Microwave Cooking

Microwave cooking allows you to customize cooking power and time. The longest cooking time is 95 minutes (95:00). You can select cooking power level by pressing POWER once or repeatedly:

Press POWER	Power	Description
Once	100%(P100)	High
twice	90%(P-90)	
3 times	80%(P-80)	
4 times	70%(P-70)	Medium High
5 times	60%(P-60)	
6 times	50%(P-50)	Medium
7 times	40%(P-40)	
8 times	30%(P-30)	Medium

9 times	20%(P-20)	Low
10 times	10%(P-10)	Low
11 times	0%(P-00)	

Suppose you want to cook for 5 minutes at 60% power level.

1. Press POWER repeatedly to select P-60.
2. Rotate TIME/MENU until the correct cooking time (5:00) is displayed.
3. Press TIME/MENU to start.

NOTE:

1. If you want to temporarily stop a cooking session, press the STOP/CANCEL once and then you can restart the cooking by pressing TIME/MENU, or press STOP/CANCEL twice to cancel the cooking program altogether.
2. After the cooking time ends, the system will beep four times and "End" will be displayed until you open the oven door or press any button.
3. Before starting another cooking session, you need to clear the display and reset the system by pressing STOP/CANCEL (Notes 1~3 are also available in the following cooking features.)

Grill

Grill cooking is particularly useful for thin slices of meat, steaks, chops, kebabs, sausages and pieces of chicken. It is also suitable for hot sandwiches and vegetable dishes. The longest cooking time is 95 minutes (95:00).

Suppose you want to program grill cooking for 12 minutes.

1. Press GRILL.
2. Turn TIME/MENU to display 12:00.
3. Press TIME/MENU to start.

Convection

During convection cooking, hot air is circulated throughout the oven cavity to brown and crisp foods quickly and evenly.

This oven can be programmed for ten different cooking temperatures (110^o~200^o). The longest cooking time is 9 hours and 30 minutes

To Cook with Convection

Suppose you want to cook at 200^o for 40 minutes(H:40).

1. Press CONVECTION repeatedly to select 200^o.
2. Rotate TIME/MENU until the correct cooking time is displayed.
3. Press TIME/MENU to start.

NOTE: You can check the convection temperature while cooking is in progress by pressing the CONVECTION.

To Preheat and Cook with Convection

Your oven can be programmed to combine preheating and convection cooking operations.

Suppose you want to preheat to 170^o and then cook for 35 minutes(H:35).

1. Press CONVECTION repeatedly to select 170^o.
2. Press TIME/MENU to start. When the oven reaches the programmed temperature, the buzzer will sound "DE" every 5 minutes.
3. Open the door and place container of food at the center of the glass tray.
4. Rotate TIME/MENU until the correct cooking time is displayed.
5. Press TIME/MENU to start.

Micro +Grill

This feature allows you to combine grill and microwave cooking on two different settings. The longest cooking time is 95 minutes (95:00).

Combination1

30% time for microwave cooking, 70% for grill cooking. Use for fish or vegetable.

Suppose you want to set combination 1 cooking for 25 minutes.

1. Press STOP/CANCEL.
2. Press COMBI. once.
3. Turn TIME/MENU to 25:00.
4. Press TIME/MENU to start.

Combination2

55% time for microwave cooking, 45% for grill cooking. Use for pudding, omelets, baked potatoes and poultry.

Suppose you want to set combination 2 cooking for 12 minutes.

1. Press STOP/CANCEL.
2. Press COMBI. twice.
3. Turn TIME/MENU to 12:00.
4. Press TIME/MENU to start.

Micro+Convection

This oven has four pre-programmed settings that make it easy to cook with both convection heat and microwave automatically. The longest cooking time is 9 hours and 30 minutes (9H:30).

Press MICRO+CONVECTION repeatedly to select convection temperature:

	Oven temperature(^o)
COMB1	110
COMB2	140
COMB3	170
COMB4	200

Suppose you want to bake food for 24 minutes (H:24) with COMB3.

1. Press MICRO +CONVECTION

- repeatedly to select 170⁰.
2. Rotate TIME/MENU until the correct cooking time is displayed.
 3. Press TIME/MENU to start.

NOTE: You can check the programmed temperature while cooking is in progress by pressing MICRO.+CONVECTION.

Jet Defrost

The longest cooking time is 95 minutes (95:00). Suppose you want to defrost frozen food for 5 minutes.

1. In standby mode, rotate TIME/MENU anti-clockwise until "9" is displayed.
2. Press CLOCK/WEIGHT once.
3. Rotate TIME/MENU to set defrosting time.
4. Press TIME/MENU to start.

NOTE: During defrosting process, the oven will pause to remind user to turn food over to obtain uniform defrosting, and then press TIME/MENU to resume defrosting.

Multi Stage Cooking

Your oven can be programmed for up to 3 automatic cooking sequences. Suppose you want to set the following cooking program.

Microwave cooking



Convection cooking (without preheat function)

1. Press POWER to set power level.
2. Rotate TIME/MENU to set cooking time.
3. Press CONVECTION repeatedly to set convection temperature.
4. Rotate TIME/MENU to set cooking time.
5. Press TIME/MENU to start.

NOTE: Jet Defrost, Quick Start and Menu Cook can not be set in the multistage cooking program.

Other Convenient Functions

KITCHEN TIMER

Your microwave oven can be used as a kitchen timer. Use the minute timer for timing up to 95 minutes.

1. Press TIMER once.
2. Turn TIME/MENU to enter the time to be counted down.
3. Press TIME/MENU to start.

NOTE: When the countdown ends, the system buzzer will sound two long tones.

Time countdown can be seen in display for 5 seconds before clock or cooking time returns to exhibit.

CHILD PROOF LOCK

The child proof lock prevents unsupervised operation by little children.

To set the child proof lock: Press STOP/CANCEL for 3 seconds, then a beep will sound and the child lock indicator light will turn on.

To cancel the child proof lock: Press

STOP/CANCEL for 3 seconds, then a beep will sound and the child lock indicator light will turn off.

COOLING FEATURE

The electrical controlling system of the microwave oven has the feature of cooling. As for any cooking mode which cooking time is above 2 minutes, after finishing cooking, the oven fan will work for about 3 minutes automatically to cool the oven for prolonging the life of the oven.

QUICK START

Use this feature to program the oven to microwave food at 100% power conveniently. The longest cooking time is 10 minutes.

Press TIME/MENU in quick succession to set the cooking time. The oven will start immediately. After time has elapsed four beeps will sound and "End" will appear on the display.

TO STOP THE OVEN WHILE THE OVEN IS OPERATING

1. Press STOP/CANCEL.

You can restart the oven by pressing

TIME/MENU.

Touch STOP/CANCEL to erase all instructions.

2. Open the Door.

You can restart the oven by closing the door and pressing TIME/MENU.

NOTE:

Oven stops operating when door is opened.

AUTOMATIC PROTECTION MECHANISM

If at anytime in the operation of the oven, the oven cavity temperature reaches 300°C, the oven automatically enters into protection mode. The display shows E 01 with beeps until STOP/CANCEL is pressed; the oven will be back to normal.

If the sensor is short circuited, the system enters into protection mode, the display shows E 03 with beeps until STOP/CANCEL is pressed, the oven will be back to normal.

InstaCook Menus

For food or the following cooking mode, it is not necessary to program the duration and the cooking power. It is sufficient to indicate the type of food that you wish to cook as well as the weight of this food. The result of auto cook depends on factors such as the shape and size of food, your personal preference as to the doneness of certain foods and even how well you happen to place the food in the oven. If you find the result at any rate not quite satisfactory, please adjust the cooking time a little bit accordingly.

To set menu cook program, please follow steps bellow:

1. In standby mode, rotate TIME/MENU anti-clockwise to select food code (see the table bellow).
2. Press CLOCK/WEIGHT to select food weight or number of servings.
3. Press TIME/MENU to start.

InstaCook Food/cooking mode	Notes
InstaCook 1 (99g)	1. Weight parameters are used to determine the time needed to do the job. As you press CLOCK/WEIGHT, the pre-set weight parameters will be displayed, when it comes up of the right figure which matches the weight of the food you have placed into the oven, press TIME/MENU. 2. For beverage and potato, parameters on the display are not food weight but number of servings. 3. For InstaCook1 and InstaCook3, there is only one choice of weight. 4. InstaCook Recipe mentioned below you will require to decide the ingredients & their quantities as per your taste.
InstaCook 2 (150ml/cup)	
InstaCook 3 (475g)	
InstaCook 4 (each 200g)	
InstaCook 5 (g)	
InstaCook 6 (g)	
InstaCook 7 (g)	
InstaCook 8 (g)	

InstaCook Recipes

InstaCook 1

Popcorn – Take approximately 99 gms of Corn in a microwave oven safe glass bowl, add butter, turmeric powder, salt to taste, (all as per your requirement and taste) mix well and cover the bowl with lid, keep it on the turn table in the Microwave oven. Select InstaCook1 and press start. Serve hot.

Masala Peanuts -Take approximately 99 gms of peanuts in a microwave oven safe glass bowl, add water, red chilly

powder, salt to taste, (all as per your requirement and taste) mix well and set aside for 15 min. Drain out the water; place the bowl on the turn table in the Microwave oven. Select InstaCook1, set weight and press start. Mix once in between. Serve hot.

Omelette – Take a Microwave oven safe bowl; add oil, cumin, chopped green chillies, turmeric powder, Tomato, Onion, salt (all as per your requirement and taste) add 1 egg and beat until all ingredients are uniformly mixed. Place

the bowl on the turn table in the Microwave oven. Select InstaCook1 and press start. Serve hot.

Garam Masala Roast – Take all together approximately 99 gms of coriander seeds, Cloves, cumin, cinnamon, cardamom, Bay leaves, salt (all as per your requirement and taste) and mix well. Place the bowl on the turn table in the Microwave oven. Select InstaCook1 and press start. Remove and set aside to cool. Grind well

Tadka – Take oil, Chopped onion, To prepare the Cake batter, take Chopped chilies, red chilly powder, cumin, mustard, turmeric power, salt, garam masala and curry leaves in a microwave oven safe bowl, (all as per your requirement and taste), mix well and place it on the turn table in the microwave oven. Select InstaCook1 and press start.

InstaCook 2

Tea/ Coffee – In a microwave safe bowl, add water, tea leaves/ Coffee powder, sugar and milk (as per your requirements) mix well, place on the turn table in the Microwave oven, select InstaCook2, set number of cups and press start.

Tomato Puree – Take tomatoes (pierced on all sides with a fork for the steam to escape) in a microwave oven safe bowl, select InstaCook2, set weight and press start. Set aside for 10 min, peel off the skin, take into a juicer jar, and grind well.

Milk boiling - Take milk in a microwave oven safe big bowl place it on the turn table in the Microwave oven, select InstaCook2, set number of cups and press start.

Hot chocolate- Take a microwave oven safe bowl add water, cocoa powder,

sugar, milk and mix well. Place the bowl on the turn table in the microwave oven, select InstaCook2, set number of cups and press start.

Veg / Chicken stock - Take chopped vegetables/ chicken in microwave oven safe bowl add 2 cups of water mix well, place on the turn table in the microwave oven select InstaCook2, set number of cups and press start. Collect the boiled water (stock) in another bowl.

InstaCook 3

Cake- Take flour (maida), ground sugar, baking powder, butter, condensed milk, chocoa powder, vanilla essence (all as per your taste and requirements) in a mixing bowl. Mix well and blend all ingredients until smooth. Pour the smooth batter into a lightly greased glass/steel/ aluminum utensil and place it on the turn table in the oven, select InstaCook3, and press start.

Cookies- To make cookies use flour (Maida), ground sugar, butter, cocoa powder, essence, baking soda, dry fruits, (all as per your taste and requirement) mix all ingredients to make dough. Shape the dough into small shapes as required, place it on lightly greased high grill rack on the turn table in the oven, select InstaCook3, and press start.

Dal Baati – To make the dough for bhati use flour (maida), ghee, ajwine, water, suji and salt (all as per your requirement and taste). Make small balls of the dough, place them on lightly greased high grill rack on the turn table in the microwave oven, select InstaCook3, and press start.

Baked Fish – In a mixing bowl, add butter (oil), tomato sauce, salt, pepper, and bread crumbs (all as per your requirements and taste) mix well. Toss the fish pieces in it and arrange them on

a lightly greased high grill rack on the turn table in the oven, select InstaCook3, and press start.

Honey, Ginger, Garlic whole chicken

– Pierce the cleaned skinless whole chicken with a fork and marinate the chicken with curd, ginger & garlic paste, honey, red chilly powder, garam masala, lime juice, corn flour, salt and set aside for 3 hours. (all as per your requirements and taste) . Place the marinated whole-chicken in a glass plate and place it on the turn table in the oven. Select InstaCook3, and press start.

InstaCook 4

Potato/ Beetroot/ Sweet Potato Boil-

Take Potato/ Beet root/ Sweet potato (pierced on all sides with a Vork for the steam to escape) select InstaCook4, set weight and press Start. Set aside for few minutes and peel off the skin.

Baigan Bhartha - Take big size eggplants (pierced on all sides with a knife for the steam to escape) place in Microwave oven, select InstaCook4, set weight and press start. Then Set aside for 10 mins, peel off the skin and then smash it. Prepare Tadka with combining egg plant mix as mentioned in InstaCook1 mentioned above and mix the egg plant into it. Serve Hot.

Egg/ Paneer Bhurji - Prepare Tadka under EC1 mentioned above. Beat egg/ Grated paneer with the prepared tadka in a microwave oven safe bowl, place in the microwave oven, select InstaCook4, set weight and press start. Mix well a couple of times while cooking. Serve Hot

Gaajar Halwa -- Take grated carrots in a microwave oven safe bowl, place on the turntable in the microwave oven, select InstaCook1 and press start. Add Ghee, kawa, sugar, milk and cardamom

powder (all as per your taste and requirement). Mix well, select InstaCook4, set the weight and press start. Serve hot

Milk Pudding – Take a microwave oven safe bowl, add milk, bread crumbs, sugar, cardamom powder, (all as per your taste and requirement) mix well, place the bowl on the turn table in the Microwave oven, select InstaCook4, set weight and press start. Serve hot or cold.

InstaCook 5

Grilled Prawns – Marinate skinned and deveined king prawns with a mixture of Butter, lime juice, ginger onion paste, red chili powder, salt (all as per your taste and requirement) and set aside for 1 hr. Arrange the king Prawns on the lightly greased Glass Plate, Place it on the turn table in the oven, select InstaCook5, set weight and press start.

Grilled Crabs / Lobsters – Marinate the cleaned Crabs and Lobsters with a mixture of oil, red chili powder, lime juice, ginger garlic onion paste, salt, coconut milk (all as per your taste and requirement) and set aside for 3 hrs. Arrange the marinated crabs/ lobsters on the lightly greased glass plate, place it on the turn table in the oven, select InstaCook5, set weight and press start.

Pizza – Take a pizza base and coat with butter, grated cheese, and top with vegetables like cabbage, capsicum, tomato ketchup, grated cheese, mushrooms etc (all as per your taste and requirement) Arrange pizza base on a glass plate, place it on the turntable in the oven, select InstaCook5, set weight and press start.

For non-veg pizza, use non-veg toppings as per your choice and taste.

Fish roast - Marinate the cleaned fish with a mixture of butter (oil), garlic

ginger paste, red chilly powder, salt, thick cream, (all as per your taste and requirement) and set aside for 2 hr. Toss marinade fish in bread crumbs or suji and arrange the fish on a lightly greased glass plate and place it on the turntable in the oven, select InstaCook5, set weight and press start.

Chicken lollypops - Marinate chicken lollypops with a mixture of curd, thick cream, oil, corn flour, red chilli powder, garam masala, ginger garlic paste, orange color (optional), lime juice and salt (all as per your taste and requirements). Set aside for 3 hours. Arrange the chicken lollypops on the lightly greased glass plate, place it on the turn table in the oven, select InstaCook5, set weight and press start. For better result turn once while grilling.

InstaCook 6

Pizza / Burger reheat – Place the precooked Pizza/ Burger on the turn table in the microwave oven and select InstaCook6, set weight and press start.

Samosa / Wada reheat - Place the precooked Samosa/ Wada on the turn table in the microwave oven and select InstaCook6, set weight and press start.

Chapati/Puri reheat – Wrap the chapattis/ Purees in a dry cloth, place on the turn table in the microwave oven, select InstaCook6, set weight and press start.

Sweet Dish Reheat – Pre cooked sweet dishes like, karanji, kalakand, Kala Jamun, Mysore paak, burfi, laddu can be reheated by selecting InstaCook6, setting weight and pressing Start.

Papad/ Rice wafers – Place the papad/rice wafers on the turn table in the microwave oven, select InstaCook6, set weight and press start.

InstaCook 7

Paneer Tikka – Marinate Paneer with a mixture of curd, cumin, thick cream, oil, corn flour, red chilli powder, garam masala, ginger garlic paste, lime juice and salt (all as per your taste and requirement). Set aside for 2 hours. Take a microwave oven safe bowl, add oil, chopped onion, chopped capsicum, chopped tomato (all as per your taste and requirement) and add the marinated paneer and mix well. Place the bowl on the turntable in the microwave oven, select InstaCook7 and press start.

Chicken kebab – Marinate Chicken pieces with a mixture of red chilli powder, garlic, salt, pepper and thick cream (all as per your taste and requirement). Set aside for 4 hrs. Arrange the Chicken pieces on the lightly greased glass plate, place it on the turn table in the microwave oven select InstaCook7, and press start.

Chicken Tandoori – Marinate chicken with a mixture of curd, thick cream, oil, corn flour, red chilli powder, garam masala, ginger garlic paste, orange color (optional), lime juice and salt (all as per your taste and requirements). Set aside for 4 hours. Arrange the tandoori chicken on lightly greased glass plate, place it on the turn table inside the microwave oven, select InstaCook7, and press start. For better result turn once while roasting.

Honey Chicken wings – Marinate the chicken wings with the mixture of Garlic ginger paste, oil, soya sauce, vanilla, honey, grounded cinnamon, mustard (all as per your requirement and taste) and set aside for 2 hours. Arrange the chicken wings on the lightly greased turn table inside the Microwave Oven, select EC7, and press start. For better result turn once while roasting.

Mutton Mince (khima) balls – Take mutton mince, add egg, bread crumbs, garlic onion paste, milk, oil, tomato sauce, sugar, mustard, salt and pepper (all as per your taste and requirement). Mix all ingredients and blend with a blender or in a mixer. Make small or required size balls of this mix and arrange them on a lightly greased glass plate, place it on the turn table inside the microwave oven, select InstaCook7, and press start. For better result turn once while roasting.

InstaCook 8

Spaghetti / Pasta / Macaroni / noodles

– Take a microwave oven safe bowl, add spaghetti/ pasta/ Macaroni/ noodles, chopped tomatoes, onions, cumin, red chilli powder, salt, pepper (all as per your requirement and taste), water and mix well. Place the bowl on the turn table in the Microwave oven and select InstaCook8, and press start.

Steamed / Jeera Rice - Take a microwave oven safe bowl, add water and rice, place on the turn table of the microwave oven select InstaCook8, and press start. For Jeera rice take oil, Jeera and salt in a microwave oven safe bowl, place on the turn table of the microwave oven select InstaCook1, set weight and press Start. Add water and rice, mix

well, place it back on the turn table in the Microwave Oven, select InstaCook8, and press start. (while making steam rice put a 1/2 glass of water in microwave turn table. for better result).

Dal Tadka – Prepare Tadka as mentioned under InstaCook1 mentioned above. Add Dal and water and place it on the turn table in the microwave oven, select InstaCook8, and press start.

Channa Masala – Take a microwave oven safe bowl, add oil, chopped onion, chopped tomato, chopped green chilli, Garlic Ginger paste, bay leaves, cinnamon, turmeric powder, salt, garam masala (all as per your requirement and taste), mix well and prepare Tadka by selecting InstaCook1 and pressing start. Add channa into it. Place on the turn table in the Microwave Oven, select InstaCook8, and press start. Serve hot.

Butter Chicken – In a microwave oven safe bowl add butter, chopped spring onions, garlic ginger paste, lime juice, soya sauce, flour (all as per your taste and requirement), mix well and Prepare Tadka by selecting InstaCook1 and pressing start. Add chicken mix well, and place the bowl on the turn table in the microwave oven, select InstaCook8, and press start.

CLEANING AND CARE

1. Turn off the oven and remove the power plug from the wall socket before cleaning.
2. Keep the inside of the oven clean. When food splatters or spilled liquids adhere to oven walls, wipe with a damp cloth. Mild detergent may be used if the oven gets very dirty. Avoid the use of spray and other harsh cleaners as they may stain, streak or dull the door surface.
3. The outside surfaces should be cleaned with a damp cloth. To prevent damage to the operating parts inside the oven, water should not be allowed to seep into the ventilation openings.
4. Wipe the door and window on both sides, the door seals and adjacent parts frequently with a damp cloth to remove any spills or spatters. Do not use abrasive cleaner.
5. Do not allow the control panel to become wet. Clean with a soft, damp cloth. When cleaning the control panel, leave oven door open to prevent oven from accidentally turning on.
6. If steam accumulates inside or around the outside of the oven door, wipe with a soft cloth. This may occur when the microwave oven is operated under high humidity condition. And it is normal.
7. It is occasionally necessary to remove the glass tray for cleaning. Wash the tray in warm sudsy water or in a dishwasher.
8. The roller ring and oven floor should be cleaned regularly to avoid excessive noise. Simply wipe the bottom surface of the oven with mild detergent. The roller ring may be washed in mild sudsy water or dishwasher. When removing the roller ring from cavity floor for cleaning, be sure to replace in the proper position.
9. Remove odors from your oven by combining a cup of water with the juice and skin of one lemon in a deep microwaveable bowl, microwave for 5 minutes. Wipe thoroughly and dry with a soft cloth.
10. When it becomes necessary to replace the oven light, please consult a dealer to have it replaced.
11. The oven should be cleaned regularly and any food deposits removed. Failure to maintain the oven in a clean condition could lead to deterioration of the surface that could adversely affect the life of the appliance and possibly result in a hazardous situation.
12. Please do not dispose this appliance into the domestic rubbish bin; it should be disposed to the particular disposal center provided by the municipalities.

TROUBLE SHOOTING

Before calling for service check the following list to be sure that a service call is necessary. Reviewing additional information on items in the following table may prevent an unneeded service call

PROBLEM	POSSIBLE CAUSES
If nothing on the oven operates	<ul style="list-style-type: none"> - Check for a blown circuit fuse or a tripped main circuit breaker. - Check if oven is properly connected to the electric circuit in house. - Check if controls are set properly
If the oven interior light does not work	<ul style="list-style-type: none"> - The light bulb is loose or defective
If oven does not cook	<ul style="list-style-type: none"> - Check that the control panel was programmed correctly - Check that the door is firmly closed - Check that Start/Enter pad was touched
If over takes longer than normal to cook or cooks too rapidly	<ul style="list-style-type: none"> - Be sure the power level is programmed properly
If the time of the day clock does not always keep the correct time	<ul style="list-style-type: none"> - Check that the power cord is fully inserted into the power outlet - Be sure the oven is the only appliance in the electrical circuit
If food cooks unevenly	<ul style="list-style-type: none"> - Be sure that the food is evenly placed - Be sure that the food is completely defrosted before cooking - Check placement of aluminum foil strips used to prevent over cooking
If food is under cooked	<ul style="list-style-type: none"> - Check recipe to be sure all directions (amount, time and power levels) were correctly followed - Be sure the oven is the only appliance in the electrical circuit - Be sure that the food is completely defrosted before cooking
If food is over cooked	<ul style="list-style-type: none"> - Check recipe to be sure all directions (amount, time power levels & size of dish) were correctly followed
If arcing (sparks) occur	<ul style="list-style-type: none"> - Be sure microwavable dishes were used. - Be sure wire-twist ties were not used - Be sure that the over was not operated when empty - Be sure that metal racks is not used in the microwave mode

FREQUENTLY ASKED QUESTIONS

QUESTION	ANSWER
Can I use a rack in my microwave oven so that I may reheat or cook in two rack positions at a time	Only use the rack that is supplied with your microwave oven. Use of any other rack can result in poor cooking performance and/or arcing and may damage your oven.
Can I use either metal or aluminum pans in my microwave oven?	Usable metal includes aluminum foil for shielding (use small, flat pieces). Never allow metal to touch the walls or door
Sometimes the door of my microwave oven appears wavy. Is this normal?	This appearance is normal and does not affect the operation of your oven.
What are the humming noises I hear when my microwave oven is operating?	This is the sound of the transformer when the magnetron tube cycles on and off.
Why does the dish become hot when I microwave food in it?	As the food becomes hot, it will conduct the heat to the dish. Use hot pads to remove food after cooking. The dish may not be microwave safe.
What does standing time mean?	Standing time means that food should be left in the oven for a short period of time after the cooking is over which allows the cooking to finish
Can I pop popcorn in my microwave oven? How do I get the best results?	Yes. Pop packaged microwave popcorn following manufactures guideline or use the pre programmed popcorn pad. Do not use regular paper bags Use the listening test by stopping the oven as soon as the popping slows to a pop every 1 to 2 secs. Do not try to repop unpopped kernels. Do not pop popcorn in glass utensils
Why does steam come out of the air exhaust vent?	Steam is normally produced during cooking. The microwave oven has been designed to vent this steam out the top vent.

MICROWAVE OVEN WARRANTY

The Godrej Microwave Oven comes with a THREE years Warranty on the magnetron and a ONE year warranty (except for plastic parts, glass components and decorative stripes, knobs etc.) against defective material or workmanship on all components of the microwave oven. Godrej & Boyce Mfg. Co. Ltd. Appliance Division undertakes repairs, free of charge during the warranty period.

INSTRUCTIONS FOR THE CUSTOMER

1. Kindly ensure that the dealer fills the warranty details correctly and completely.
2. You should retain the warranty page for record and produce the same in the event of any warranty repairs.
3. In the event of a defect developing in the product, contact the nearest authorised Godrej & Boyce Service Centre for obtaining warranty service and inform the defect, model details and Serial No.

TERMS AND CONDITIONS

1. Repairs and replacement of parts will be earned out through the authorised customer service centre.
2. For units installed beyond the municipal limits of the jurisdiction of the authorised customer care centre all expenses incurred in collecting the units or parts thereof from the company's customer care centre, as well as expenses incurred with depositing of service personnel/technician's towards conveyance and other incidents will be borne by the customer.
3. The concerned customer care centre will advise the customer whether to effect the repair at site or at the customer care centre.
4. While the company will make every effort to carry out the repairs at the earliest, it however is made expressly clear that the company is under no obligation to do so in a specified period of time.
5. The company or its authorised customer care centre/service dealer reserves the right to retain any parts, components replaced at its discretion.
6. Warranty does not cover accessories to the equipment.
7. The warranty is confined to the first purchaser of MWO only and non-transferable.
8. Call registered with the centralised helpline/authorised service centre, where in only cleaning of the unit/parts in the unit due to dust accumulation on portions of the units are not to be considered as defects.
9. **In case of any damages to the product, customer abuse, repairs by unauthorised personnel & misuse detected by the authorised service centre personnel, the warranty conditions are not applicable.**
10. If any coloured internal or external components are replaced, effort will be made to ensure that the shades match with the original or other components. However, the replaced shades, pattern, tints may vary from the customer's unit due to usage of the unit. Any matching components changed at customer's request will be charged, except the component which is actually needed.
11. **The unit shall be operated with variation +/-5% of the rated voltage. Fluctuation beyond specified tolerance will not be covered under warranty. Customer shall not operate the product below 210V under any circumstances.**
12. Parts not covered - Main door, Glass, Bulb, Rubber, Plastic Components.
13. This warranty does not cover any type of painting, plating including rusting etc. or defects thereof.
14. **The Appliance or any part thereof is subjected to neglect, abuse or misuse, tampering, alteration, accident, fire, floods or other acts of God, or damage by rodents or insects, the COMPANY is not responsible for any damage caused to the appliance & Shall not be liable for any consequential loss compensation. nor refund of purchase price or replacement of the appliance.**

Godrej & Boyce Mfg. Co. Ltd.- Appliance Division

WARRANTY DETAILS

MODEL NO.

UNIT SR. NO.

CUSTOMER'S NAME & ADDRESS

TEL. _____

UNIT SR. NO.

DEALER'S NAME & ADDRESS

TEL. _____

Customer's Signature:

Dealer's Signature:

This card is valid only if it is filled in and stamped by our authorised dealer on the date of purchase.

Warranty is Void If:

1. The warranty card is not completed properly at the time of purchase.
2. The completed warranty card is not presented to the authorised personnel at the time of service of the product.
3. The microwave is not operated according to instructions given in the 'User Guide'.
4. Defects are caused by improper or reckless use, which shall be determined by the company personnel.
5. Any repair work earned out by persons other than authorised company personnel.
6. Defects caused beyond control like abnormal voltage, acts of God, or while in transit to service centre or purchaser's residence.
7. The warranty is not valid in case the serial number is deleted, defaced or altered.
8. Damage to the microwave or any parts due to transportation or shifting is not covered by the warranty.
9. The warranty automatically expires after 12 month of original date of purchase, even if the microwave may not be in use for any time for whatever reasons during the warranty period.

GODREJ & BOYCE MFG. CO. LTD., Appliances Division

Branch	Address
Ahmedabad	4th Floor, APM Shopping Mall Near IOCL Petrol Pump, Shyamal-Karnavati, 100 ft. Road, Satellite, Ahmedabad - 380 015
Bangalore	3rd Floor, The Karnataka Film Chamber of Commerce Bldg. 28, 1st Main, Crescent Road, High Grounds Nr. Shivanand Circle, Bangalore - 560 001
Bhopal	217, Zone I, M.P. Nagar, Beh. Jyoti Talkies, Bhopal - 462 011
Bhubaneshwar	Highway Complex, NH-5, Rudrapur, Bhubaneshwar - 752 101
Chandigarh/Mohali	Plot No. A-40, Phase VIII-A, Industrial Area, Mohali - 160 059
Chennai	No. 1, Sidco Industrial Estate, Ambattur, Chennai - 600 098
Coimbatore	No. 585 - 590 3rd Floor, Sathya Towers, DB Road, R S Puram, Coimbatore - 641002
Delhi	Godrej Bhavan, 2nd Floor, Shershah Suri Marg, Mathura Road, Okhla, New Delhi - 110 065
Faridabad	Godrej Bhavan, 2nd Floor, Shershah Suri Marg, Mathura Road, Okhla, New Delhi - 110 065
Ghaziabad	Plot No. 229/230, Sardar Pashu Ahaar, Bulandshahar Road, Village-chaprola, Ghaziabad
Guwahati	Basundhara Enclave, 1st & 2nd Floor Ulubari, Guwahati - 781007
Hyderabad	201 & 202, Lala-1 Land Mark, 5-4-94 to 97, 2nd Floor, Above Digital Shoppo, Ranigunj, M.G. Road, Secunderabad -500 003
Jaipur	502-506, 5th Floor, Gaurav Towers, Malviya Nagar, Jaipur - 302 017
Kochi	2nd floor, Angels Arcade, South Kalamasserry, Near CUSAT PO Kochi - 682022
Kolkata	Plot-30, Block-GN, Sector-V, Salt Lake city, Kolkata - 700 091
Lucknow	C-3/3 & C-3/4, Sanjay Complex, Near All India Radio, Vidhan Sabha Marg, Lucknow-226001
Mumbai	Appliance Division, Plant 4, Pirojshahnagar, Vikhroli, Mumbai - 400 079
Nagpur	Dr. Bhiwapurkar Chamber, 2nd Floor, Opp. Yashwant Stadium, Dhantoli, Nagpur - 440 012
Patna	Grand Plaza 6th Floor, 6001-6004, Dakbunglow Crossing. Frazer Road. Patna-800001
Pune	Apollo Building Square, Plot No. 60, Survey No. 599, Sahaney Sujan Park, Lullanagar, Bibewadi Road, Pune - 411 040
Raipur	9/1, Besides Bharat Petrol Pump, Opp, Hotel Picadelly, Mahoba Bazaar, G.E. Road, Raipur - 492 001, Chhatisgarh
Ranchi	C/o. Surya Motors, Near Krishi Bazaar Samiti Pandra, Ranchi (Jharkand) - 835 222

Toll-Free :1800-209-5511

Website: www.godrejappliances.com & www.godrejsmartcare.comE-mail: smartcare@godrej.com

Protection of Environment:



"Protection of environment" is one of the core values of Godrej and we seek your co-operation to make sure that this product is not disposed as unsorted municipal waste.

This symbol is known as the "Crossed-out Wheelie Bin Symbol". It means that the product should not be disposed of with your general house-hold waste.

It should be disposed of only through the company's collection centers with special treatment so as to prevent any damage to the environment. **Please call:**

1800 209 5511 or visit: www.godrejappliances.com/green-think for details about Godrej Appliances authorized collection centers.

Godrej | APPLIANCES