

MODEL: GMX 20 CA5 MLZ
CONVECTION MICROWAVE OVEN

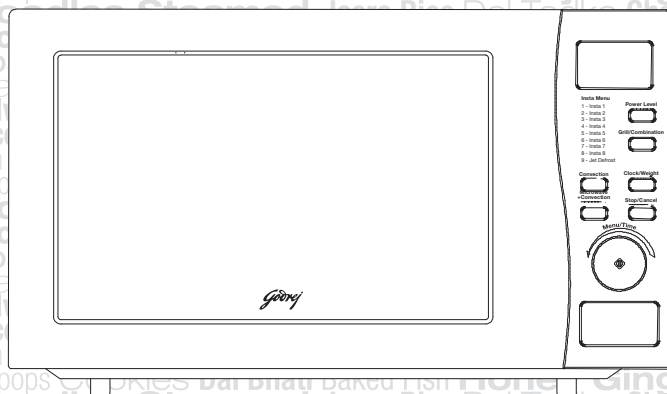

Please read these instructions carefully before installing and operating the oven.

Record in the space below the SERIAL NO. found on the nameplate on your oven and retain this information for future reference.

SERIAL NO. _____

The above image is for representative purpose, actual image of the product may vary

PRECAUTIONS TO AVOID POSSIBLE EXPOSURE TO EXCESSIVE MICROWAVE ENERGY

1. Do not attempt to operate this oven with the door open since open door operation can result in harmful exposure to microwave energy. It is important not to tamper with the safety interlocks.
2. Do not place any object between the oven front face and the door or allow soil or cleaner residue to accumulate on sealing surfaces.
3. Do not operate the oven if it is damaged. It is particularly important that the oven door close properly and that there is no damage to the
 - a. Door (bent),
 - b. Hinges and latches (broken or loosened),
 - c. Door seals and sealing surfaces.
4. The oven should not be adjusted or repaired by anyone except properly qualified service personnel.

CONTENTS

PRECAUTIONS TO AVOID POSSIBLE EXPOSURE TO EXCESSIVE MICROWAVE ENERGY .	1
IMPORTANT SAFETY INSTRUCTIONS .	2
SPECIFICATIONS	4
INSTALLATION	4
RADIO INTERFERENCE .	4
GROUNDING INSTRUCTIONS .	5
MICROWAVE COOKING PRINCIPLES .	5
BEFORE YOU CALL FOR SERVICE .	5
UTENSILS GUIDE	6
PART NAMES	6
CONTROL PANEL	7
HOW TO SET THE OVEN CONTROLS .	8
SETTING THE CLOCK	8
MICROWAVE COOKING	8
QUICK START	8
GRILL	9
MICRO +GRILL	9
CONVECTION	9
MICROWAVE +CONVECTION	10
JET DEFROST	10
MULTI-STAGE COOKING	11
CHILD LOCK	11
OTHER FEATURE	12
CLEANING AND CARE	13
INSTACOOK RECIPE	14
WARRANTY CARD	89
BRANCH ADDRESS	90

IMPORTANT SAFETY INSTRUCTIONS

READ CAREFULLY AND KEEP FOR FUTURE USE

Important Safety instructions

The Safety instructions mentioned below will tell you how to use your Microwave Oven without harming yourself and damaging your oven.

Warning – To reduce the risk of burns, electric shock, fire, injury to persons, or exposure to excessive microwave energy

- Read all the instructions before using your oven
- Do not allow children to use this oven without close supervision

Precautions to avoid possible exposure to excessive microwave energy:

- a) Do not attempt to operate this oven with the door open since open door operation can result in harmful exposure to microwave energy. It is important not to tamper with the safety interlocks.
- b) Do not place any object between the microwave oven cavity and the door or allow soil or cleaner residue to accumulate on sealing surfaces
- c) Do not operate the oven if it is damaged. It is particularly important that the oven door closes properly and that there is no damages to the:
 - i. Door (bent)
 - ii. Hinges and latches (broken or loosened)
 - iii. Door seals and sealing surfaces
- d) It is hazardous for anyone other than properly qualified competent service personnel to repair, adjust or remove the cover which gives protection against exposure to microwave energy

1. **Do not heat the following items in the microwave oven:** Whole eggs in the shell, water with oil or fat, sealed containers, or closed glass jars.

These items may explode.

- Do not cover or block any openings in the oven
- Use your oven only for the operations described in this manual
- Do not run the oven empty, without food in it
- Do not deep fry in your microwave oven
- Do not remove the turn table while using the microwave oven

- Do not make popcorn, peanuts and suji roast in plastic utensil. Use only microwaveable glass utensil.
2. Only use utensils suitable for use in microwave oven
 3. Remove wire twist-ties and metal handles from paper or plastic containers/bags before placing them in the oven
 4. The oven should be cleaned regularly and any food deposits should be removed. Failure to maintain the oven in a clean condition could lead to deterioration of the surface, and could adversely affect the life of the appliance and possibly result in a hazardous situation.
 5. When the appliance is operated in the combination mode, children should only use the oven under adult supervision due to the temperatures generated.
 6. To avoid a fire hazard do not severely overcook food. Severely overcooked foods can start a fire in the oven.
 7. When heating food in plastic or paper containers, keep an eye on the oven due to the possibility of ignition.
 8. If smoke is observed, switch off or unplug the appliance and keep the door closed in order to stifle any flames
 9. Do not use the cavity for storage purposes. Do not leave paper products, cooking utensils, or food in the cavity when not in use.
 10. Do not use this oven for commercial purposes. This appliances is intended to be used in household and similar application such as:
 - Staff Kitchen areas in shops, offices and other working environments;
 - Farm Houses;
 - By clients in hotels, motels and other residential environments;
 - Bed and breakfast type environments.
 11. When cleaning the door and the surfaces that touch the door, use only mild, non-abrasive soaps or detergents and a sponge or soft cloth
 12. Do not use corrosive chemicals or vapours, in this appliance. This type of oven is specifically designed to heat, cook, or dry food. It is not designed for industrial or laboratory use

13. Do not use or store this appliance outdoors. Do not use this product near water for example near a kitchen sink, in a wet basement, or near a swimming pool, and the likes.
14. Do not tamper with the built-in safety switches on the oven door. The oven has several built-in safety switches to make sure the power is off when the door is open.
15. If the supply cord is damaged, it must be replaced by the manufacturer, its service agent or similarly qualified persons in order to avoid a hazard
16. If your oven is dropped or damaged, have it thoroughly checked by a qualified service technician before using it again
17. The temperature of accessible surfaces may be high when the appliance is operating. Keep cord away from heated surface, and do not cover the oven.
18. Do not immerse the electrical cord or plug in water
19. Pierce food with heavy skin such as potatoes, whole squashes, apples, tomatoes, brinjals, mutton, chicken before cooking
20. Cooking utensils may become hot because of heat transferred from heated food. Potholders may be needed to handle the utensils. Utensils should be checked to ensure that they are suitable for use in microwave ovens.
21. The microwave oven shall not be placed in a cabinet
22. Liquids, such as water, coffee, or tea can be overheated beyond the boiling point without appearing to be boiling. Visible bubbling or boiling when the container is removed from the microwave oven is not always present. **THIS COULD RESULT IN VERY HOT LIQUIDS SUDDENLY BOILING OVER WHEN THE CONTAINER IS DISTURBED OR A SPOON OR OTHER UTENSIL IS INSERTED INTO THE LIQUID.**
23. To reduce the risk of injury to persons:
 - Do not overheat the liquid
 - Stir the liquid both before and halfway through heating it
 - While cooking or reheating in microwave mode, ensure the vent of the lid is kept open at all times or the lid is partially open
 - After heating, allow the container to stand in the microwave oven for a short time before removing the container
 - Use extreme care when inserting a spoon or other utensil into the container
24. The contents of feeding bottles and baby food jars shall be stirred or shaken and the temperature checked before consumption, in order to avoid burns
25. The appliances is not intended for use by persons (including children) with reduced physical, sensory or mental capabilities, or lack of experience and knowledge, unless they have been given supervision or instruction concerning use of the appliance by a person responsible for their safety
26. The rear surface of the appliance shall be placed against the wall
27. Microwave oven is intended for heating food and beverages. Drying of food or clothing and heating of warming pads, slippers, sponges, damp cloth and similar may lead to risk of injury, ignition or fire.
28. Microwave heating of beverages can result in delayed eruptive boiling, therefore care must be taken when handling the container.
29. Details for cleaning door seals, cavities and adjacent parts are given on page **CLEANING AND CARE.**
30. No temperature sensing probe to be inserted into the food placed inside the cavity of this oven by user, during switched ON state.
A temperature probe may be placed on the food once the food is taken outside the oven.
31. The microwave is intended to be used freestanding.

SPECIFICATIONS

Rated Voltage	230V~, 50Hz,
Rated Power Input	1200W (Microwave)
	1200W (Grill)
	2200W (Convection)
Rated Microwave Power Output:	800W
Operation Frequency:	2450MHz
Net Dimension (HxWxD)	24.2 cm×45.0 cm× 32.0cm
Oven Capacity:	20Litres
Net Weight:	Approx 13.27kg

INSTALLATION

1. Make sure that all the packing materials are removed from the inside of the door.
2. **WARNING:** Check the oven for any damage, such as misaligned or bent door, damaged door seals and sealing surface, broken or loose door hinges and latches and dents inside the cavity or on the door. If there is any damage, do not operate the oven and contact qualified service personnel.
3. This microwave oven must be placed on a flat, stable surface to hold its weight and the heaviest food likely to be cooked in the oven.
4. Do not place the oven where heat, moisture, or high humidity are generated, or near combustible materials.
5. For correct operation, the oven must have sufficient airflow. Allow 20cm of space above the oven, 10cm at back and 5cm at both sides. Do not cover or block any openings on the appliance. Do not remove feet.
6. Do not operate the oven without glass tray, roller support, and shaft in their proper positions.
7. Make sure that the power supply cord is undamaged and does not run under the oven or over any hot or sharp surface.
8. The socket must be readily accessible so that it can be easily unplugged in an emergency.
9. Do not use the oven outdoors.

RADIO INTERFERENCE

Operation of the microwave oven can cause interference to your radio, TV, or similar equipment.

When there is interference, it may be reduced or eliminated by taking the following measures:

1. Clean door and sealing surface of the oven.
2. Reorient the receiving antenna of radio or television.
3. Relocate the microwave oven with respect to the receiver.
4. Move the microwave oven away from the receiver.
5. Plug the microwave oven into a different outlet so that microwave oven and receiver are on different branch circuits.

GROUNDING INSTRUCTIONS

This appliance must be grounded. This oven is equipped with a cord having a grounding wire with a grounding plug. It must be plugged into a wall receptacle that is properly installed and grounded. In the event of an electrical short circuit, grounding reduces risk of electric shock by providing an escape wire for the electric current. It is recommended that a separate circuit serving only the oven be provided. Using a high voltage is dangerous and may result in a fire or other accident causing oven damage.

WARNING Improper use of the grounding plug can result in a risk of electric shock.

Note:

1. If you have any questions about the grounding or electrical instructions, consult a qualified electrician or service person.
2. Neither the manufacturer nor the dealer can accept any liability for damage to the oven or personal injury resulting from failure to observe the electrical connection procedures.

The wires in this cable main are colored in accordance with the following code:

Green and Yellow = EARTH

Blue = NEUTRAL

Brown = LIVE

MICROWAVE COOKING PRINCIPLES

1. Arrange food carefully. Place thickest areas towards outside of dish.
2. Watch cooking time. Cook for the shortest amount of time indicated and add more as needed. Food severely overcooked can smoke or ignite.
3. Cover foods while cooking. Covers prevent spattering and help foods to cook evenly.
4. Turn foods over once during microwaving to speed cooking of such foods as chicken and hamburgers. Large items like roasts must be turned over at least once.
5. Rearrange foods such as meatballs halfway through cooking both from top to bottom and from the center of the dish to the outside.

BEFORE YOU CALL FOR SERVICE

If the oven fails to operate:

1. Check to ensure that the oven is plugged in securely. If it is not, remove the plug from the outlet, wait 10 seconds, and plug it in again securely.
2. Check for a blown circuit fuse or a tripped main circuit breaker. If these seem to be operating properly, test the outlet with another appliance.
3. Check to ensure that the control panel is programmed correctly and the timer is set.
4. Check to ensure that the door is securely closed engaging the door safety lock system. Otherwise, the microwave energy will not flow into the oven.

IF NONE OF THE ABOVE RECTIFIES THE SITUATION, THEN CONTACT A QUALIFIED TECHNICIAN. DO NOT TRY TO ADJUST OR REPAIR THE OVEN YOURSELF.

UTENSILS GUIDE

1. The ideal material for a microwave utensil is transparent to microwave, it allows energy to pass through the container and heat the food.
 2. Microwave cannot penetrate metal, so metal utensils or dishes with metallic trim should not be used.
 3. Do not use recycled paper products when microwave cooking, as they may contain small metal fragments which may cause sparks and/or fires.
 4. Round /oval dishes rather than square/oblong ones are recommend, as food in corners tends to overcook.
 5. Narrow strips of aluminum foil may be used to prevent overcooking of exposed areas. But be careful don't use too much and keep a distance of 1 inch (2.54cm) between foil and cavity.
- The list below is a general guide to help you select the correct utensils.

Cookware	Microwave	Grill	Convection	Combination*
Heat-Resistant Glass	Yes	Yes	Yes	Yes
Non Heat-Resistant Glass	No	No	No	No
Heat-Resistant Ceramics	Yes	Yes	Yes	Yes
Microwave-Safe Plastic Dish	Yes	No	No	No
Kitchen Paper	Yes	No	No	No
Metal Tray	No	Yes	Yes	No
Metal Rack	No	Yes	Yes	No
Aluminum Foil & Foil Container	No	Yes	Yes	No

* Combination: applicable for both "microwave+grill", and "microwave+convection" cooking.

PART NAMES

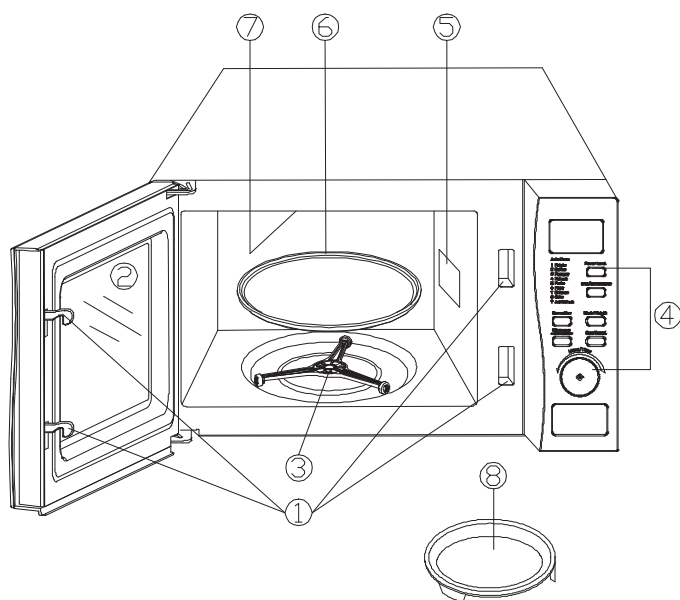

1. Door Safety Lock System
2. Oven Window
3. Turntable supporter
4. Control Panel
5. Wave Guide
(Please do not remove the mica plate covering the wave guide)
6. Glass Tray
7. Grill Heater
8. Baking Plate

CONTROL PANEL

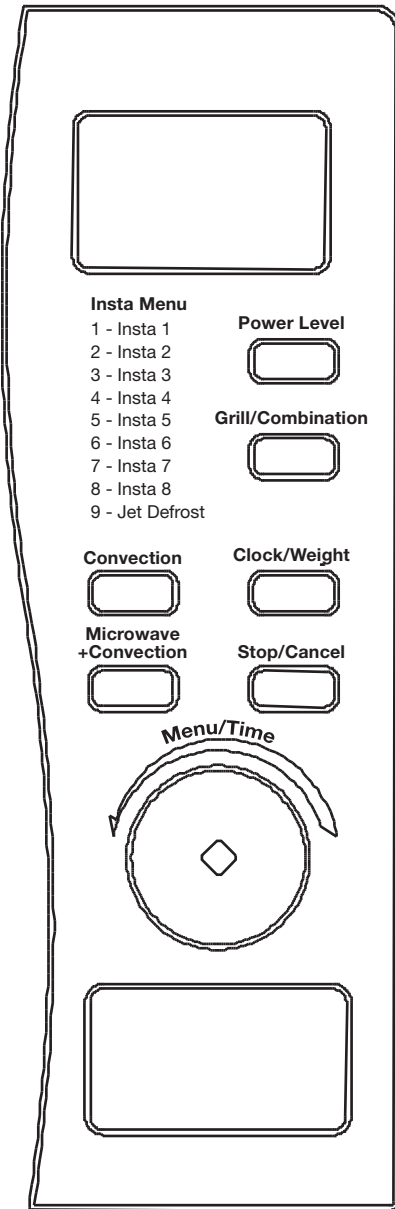

DISPLAY SCREEN

Cooking time, power, indicators and present time are displayed.

POWER LEVEL

Press to select microwave power level.

GRILL/COMBINATION

Press to set a grill cooking program.

Press to select one of two combination cooking settings.

CONVECTION

Press to program convection temperature.

CLOCK / WEIGHT

press to set clock time.

Press to select the amount of food.

MICROWAVE +CONVECTION

Press to select one of four combination cooking settings.

STOP / CANCEL

Touch to stop cooking program or clear all previous settings before cooking starts.

MENU/TIME (DIAL)

Rotate to set cooking time or select auto-menu.

START/QUICK START

Touch to start the oven or press a number of times to set cooking time and start immediately.

HOW TO SET THE OVEN CONTROLS

SETTING THE CLOCK

1. Press CLOCK / WEIGHT button to set the clock in 12 or 24-hour cycle.
2. Rotate the MENU/TIME dial until the correct hour is displayed.
3. Press CLOCK / WEIGHT button once.
4. Rotate the MENU/TIME dial until the correct minute is displayed.
5. Press CLOCK / WEIGHT button to confirm.

Note: Press the CLOCK / WEIGHT button during the cooking, the current time will display.

MICROWAVE COOKING

The maximum cooking time is 95 minutes.

Suppose you want to cook for 5 minute at 60% power level.

1. Press POWER LEVEL button a number of times till the screen show P-60.

Press POWER LEVEL	Power Level	Display
1×	100%	P100
2×	90%	P-90
3×	80%	P-80
4×	70%	P-70
5×	60%	P-60
6×	50%	P-50
7×	40%	P-40
8×	30%	P-30
9×	20%	P-20
10×	10%	P-10
11×	0%	P-00

2. Rotate the MENU/TIME dial to enter cooking time until the correct cooking time (5:00) is displayed.
3. Press START/QUICK START button to start.

NOTE: If you want to temporarily stop a cooking session, press the STOP/CANCEL button once and then you can restart the cooking again by pressing START/QUICK START button; press the STOP/CANCEL twice will cancel the cooking program altogether.

QUICK START

Use this feature to program the oven to start at 100% power conveniently.

Press START/QUICK START button in quick succession to set the cooking time.

Note: The maximum cooking time you can set is 10 minutes.

GRILL

The maximum cooking time is 95 minutes.

Grill cooking is particularly useful for thin slices of meat, steaks, chops, kebabs, sausages and pieces of chicken. It is also suitable for hot sandwiches and au gratin dishes.

Suppose you want to program grill cooking for 12 minutes.

1. Press GRILL/COMBINATION button once.
2. Rotate the MENU/TIME dial to 12:00.
3. Press START/QUICK START button to start.

MICRO +GRILL

The maximum cooking time is 95 minutes.

During cooking, you can see the programmed setting by pressing this button.

COMBINATION 1

30% time for microwave cooking, 70% for grill cooking. Use for fish and French fries.

Suppose you want to set combination 1 cooking for 25 minutes.

1. Press GRILL/COMBINATION button twice.
2. Rotate MENU/TIME dial to 25:00.
3. Press START/QUICK START to start.

COMBINATION 2

55% time for microwave cooking, 45% for grill cooking. Use for pudding, omelets and chicken tandoori.

Suppose you want to set combination 2 cooking for 12 minutes.

1. Press GRILL/COMBINATION button thrice.
2. Rotate MENU/TIME dial to 12:00.
3. Press START/QUICK START button to start.

CONVECTION

During convection cooking, hot air is circulated throughout the oven cavity to brown and make crisp foods quickly and evenly. This oven can be programmed for ten different cooking temperatures. Maximum cooking time for convection is 9 hours 30 minutes (9H:30).

To Cook with Convection

To cook with convection, press CONVECTION button repeatedly to enter the desired convection temperature (200~110°C) .

Suppose you want to cook at 180°C for 40 minutes (H:40).

1. Press CONVECTION button repeatedly to select desired cooking temperature.
2. Rotate the MENU/TIME dial to enter desired cooking time.
3. Press START/QUICK START button to start.

NOTE:

You can check the convection temperature while cooking is in progress by pressing the CONVECTION button.

To Preheat and Cook with Convection

Your oven can be programmed to combine preheating and convection cooking operations.

Suppose you want to preheat to 170°C and then cook 35 minutes (H:35).

1. Press CONVECTION button repeatedly to select desired preheat temperature.
2. Press START/QUICK START button to start. Beeps will sound when the designated temperature is reached.
3. Open the door and place container of food at the center of the turntable.
4. Rotate the MENU/TIME dial to enter cooking time.
5. Press START/QUICK START button to start.

MICROWAVE + CONVECTION

This oven has four pre-programmed settings that make it easy to cook with both convection heat and microwave automatically.

Press MICRO+CONVECTION button repeatedly to program convection temperature:

	Touch	temperature(°C)
COMB1	Once	200
COMB2	Twice	170
COMB3	3 times	140
COMB4	4 times	110

Suppose you want to bake a cake for 24 minutes(H :24) on COMB3.

1. Press MICRO+CONVECTION button 3 times.
2. Use the MENU/TIME dial to enter cooking time as desired
3. Press START/QUICK START button to start.

NOTE:

You can check the convection temperature while cooking is in progress by pressing the MICRO+CONVECTION button.

JET DEFROST

Suppose you want to defrost frozen food.

1. Rotate the MENU/TIME dial to select corresponding code A-9.
2. Press CLOCK / WEIGHT button once.
3. Rotate the MENU/TIME dial to enter desired cooking time.
4. Press START/QUICK START to start.

Note: During defrosting process, the oven will pause to remind user to turn food over to obtain uniform defrosting.

MULTI-STAGE COOKING

Your oven can be programmed for up to 3 automatic cooking sequences.

Suppose you want to set the following cooking program.

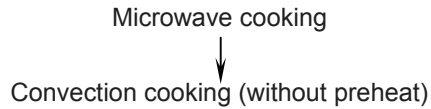

1. Press MICRO. button to set power level.
2. Rotate the MENU/TIME dial to program microwave cooking time.
3. Press CONVECTION button to set convection temperature.
4. Rotate the MENU/TIME dial to program convection cooking time.
5. Press START/QUICK START button to start.

QUICK START, PREHEAT with CONVECTION and INSTA MENU cannot be set in a multi-stage cooking program.

CHILD LOCK

The child lock prevents unsupervised operation by little children.

To set the child lock: Press and hold STOP/CANCEL button for 3 seconds, then a beep will sound and the LOCK indicator light will come on. In the lock state, all buttons are disabled.

To cancel the child lock: Press and hold STOP/CANCEL button for 3 seconds, then a beep will sound and the LOCK indicator light will turn off.

OTHER FEATURE

TO STOP THE OVEN WHILE THE OVEN IS OPERATING

1. Press STOP/CANCEL button once.

You can restart the oven by pressing START/QUICK START button.

Touch STOP/CANCEL again to erase all instructions.

2. Open the door.

You can restart the oven by closing the door and pressing START/QUICK START button.

NOTE:

Oven stops operating when door is opened.

AUTO PROTECTION

1. High Temperature protection: when the machine runs for long and it's temperature goes high, display will show E-1 and beep will sound -- which indicates the machine goes into high temperature protection mechanism. When temperature goes down and machine goes into standby mode or press STOP/CANCEL button, above alarming display and sound will disappear.
2. Low temperature protection: when the machine runs for long and it's temperature goes low, display will show E-2 and beep will sound - which indicates the machine goes into high temperature protection mechanism. When temperature goes down and machine goes into standby mode or press STOP/CANCEL button, above alarming display and sound will disappear.
3. System error: display may show E-3 and beep sounds when system error, open circuit or short circuit happen. Machine will resume back to standby mode when STOP/CANCEL button is pressed.

COOLING FEATURE

The electronic controlling system of the microwave oven has the feature of cooling. As for any cooking mode which cooking time above 2 minutes, after finishing cooking, the oven fan will work about 3 minutes automatically to cool the oven for prolonging the life of the oven.

CLEANING AND CARE

1. Turn off the oven and remove the power plug from the wall socket before cleaning.
2. Keep the inside of the oven clean. When food splatters or spilled liquids adhere to oven walls, wipe with a damp cloth. Mild detergent may be used if the oven gets very dirty. Avoid the use of spray and other harsh cleaners as they may stain, streak or dull the door surface.
3. The outside surfaces should be cleaned with a damp cloth. To prevent damage to the operating parts inside the oven, water should not be allowed to seep into the ventilation openings.
4. Wipe the door and window on both sides, the door seals and adjacent parts frequently with a damp cloth to remove any spills or splatters. Do not use abrasive cleaner.
5. Do not allow the control panel to become wet. Clean with a soft, damp cloth. When cleaning the control panel, leave oven door open to prevent oven from accidentally turning on.
6. If steam accumulates inside or around the outside of the oven door, wipe with a soft cloth. This may occur when the microwave oven is operated under high humidity condition. And it is normal.
7. It is occasionally necessary to remove the glass tray for cleaning. Wash the tray in warm sudsy water or in a dishwasher.
8. The roller ring and oven floor should be cleaned regularly to avoid excessive noise. Simply wipe the bottom surface of the oven with mild detergent. The roller ring may be washed in mild sudsy water or dishwasher. When removing the roller ring from cavity floor for cleaning, be sure to replace in the proper position.
9. Remove odors from your oven by combining a cup of water with the juice and skin of one lemon in a deep microwaveable bowl, microwave for 5 minutes. Wipe thoroughly and dry with a soft cloth.
10. When it becomes necessary to replace the oven light, please consult a dealer to have it replaced.
11. The oven should be cleaned regularly and any food deposits removed. Failure to maintain the oven in a clean condition could lead to deterioration of the surface that could adversely affect the life of the appliance and possibly result in a hazardous situation.
12. Please do not dispose this appliance into the domestic rubbish bin; it should be disposed to the particular disposal center provided by the municipalities.
13. When the microwave oven with grill function is first used, it may produce slight smoke and smell. This is a normal phenomenon because the oven is made of a steel plate coated with lubricating oil, and the new oven will produce fumes and odor generated by burning the lubricating oil. This phenomenon will disappear after a period of using.

INSTA MENU'S

For food or the following cooking mode, it is not necessary to program the duration and the cooking power. It is sufficient to indicate the type of food that you wish to cook as well as the weight of this food.

Note: To select a specific recipe from those given below, identify the InstaCook menu it falls under (Insta1, Insta2, etc), rotate the jog dial in the anti clockwise direction and select the relevant Insta menu. The InstaCook menu will be displayed as A1, A2,A9.

1. Rotate the digital knob MENU/TIME to select food code from INSTA-1~INSTA-8, to specify the food to be cooked.
2. Press CLOCK / WEIGHT to enter weight (also see note 2 in the following table for more information), check the screen for number of servings or preset weights, which should match weight of food you have placed in the oven.
3. Press START/QUICK START to start.

Select food code	Notes
Insta 1	1. The user is required to set weight for the system to determine the time needed to do the job. 2. For food Insta 7, beeps can be heard in half cooking time to remind user to turn food over for uniform cooking.
Insta 2	
Insta 3	
Insta 4	
Insta 5	
Insta 6	
Insta 7	
Insta 8	

INSTACOOK MENU'S

Recipe Name	Recipe Code	Ingredients & Method of Preparation	Weight		
UPMA	Insta 1	UPMA	230 gms	460 gms	690 gms
		Ingredients;			
		roasted semolina (suji)	2 cup	3 cup	4 cup
		onions medium sized (finely chopped)	1	2	2
		green chilly (finely chopped)	2	3	4
		curry leaves	few	few	few
		mustard	½ tsp	½ tsp	1 tsp
		cumin's seeds	½ tsp	½ tsp	1 tsp
		turmeric powder	¼ tsp	½ tsp	½ tsp
		groundnuts (roasted)	½ tbsps	½ tbsps	1 tbsps
		channa dhal	2 tsp	2 tsp	3 tsp
		urad dhal	2 tsp	2 tsp	3 tsp
		tomato (chopped)	¼ cup	¼ cup	½ cup
		green peas	½ tbsps	½ tbsps	1 tbsps
		carrot (chopped)	¼ cup	¼ cup	½ cup
		ghee as required			
		salt to taste			
		water as required			
		grated coconut & shev for garnish			
		Method of preparation:			
		Prepare tadka in a microwave oven safe bowl as explained in Insta 3 with all the ingredients other than roasted suji and water. After beep, remove and add the remaining ingredients, mix well. Place the bowl in the microwave oven, select Insta 1, enter weight and press start. Garnish with coconut & shev, serve hot.			

Recipe Name	Recipe Code	Ingredients & Method of Preparation	230gms	460gms	690gms
FRUIT CUSTARD	Insta 1	FRUIT CUSTARD			
		Ingredients:			
		Custard Powder	½ cup	½ cup	1 cup
		Milk	2 cup	3 cup	5 cup
		Sugar	1 cup	1½ cup	2 cups
		Apple	1	1	2
		Banana	2	2	3
		Pineapple Slices	¼ cup	¼ cup	½ cup
		Strawberries	¼ cup	¼ cup	½ cup
		Black Grapes (Seedless)	¼ cup	¼ cup	½ cup
		Green Grapes (Seedless)	¼ cup	¼ cup	½ cup
		Cherries To Garnish	¼ cup	¼ cup	½ cup
		Method of preparation;			
		Take a microwave oven safe large glass bowl; add milk, sugar, custard powder and mix well. Place the bowl in the microwave oven, select Insta 1, enter weight and press start. Slice the apple, banana, pineapple into pieces and put them into a bowl which is large enough to hold all the contents. The grapes and the strawberries need not be cut and should be added along with it. Add custard to the fruits and mix gently. Set to cool and serve.			

NOODLES	Insta 1	NOODLES	230gms	460gms	690gms
		Ingredients:			
		Noodles – Boiled	100 gms	150 gms	200 gms
		Mixed Vegetables(Carrots, Beans, Cauliflower, Baby Corn)	100 gms	200 gms	350 gms
		Mushrooms – Sliced	50 gms	100 gms	150 gms
		Garlic – Chopped	½ tsp	½ tsp	1 tsp
		Ginger – Chopped	½ tsp	½ tsp	1 tsp
		Soya Sauce	2 tsp	3 tsp	4 tsp
		Spring Onions – Chopped	½ tbsp	½ tbsp	1 tbsp
		Oil As Required			
		Pepper To Taste			
		Salt To Taste			
		Method of preparation:			
		Prepare tadka as mentioned in Insta 3 with all the ingredients other than noodles and soya sauce. After beep, remove, add noodles & soya sauce, mix smoothly, select Insta 1, enter weight and press start. Serve hot			

PALAK PANEER	Insta 1	PALAK PANEER	230gms	460gms	690gms
		Ingredients:			
		Paneer	150 gms	300 gms	500 gms
		Palak Paste	2 cup	3 cup	4 cup
		Onion Paste	1 cup	2 cup	3 cup
		Black Pepper Powder	½ tsp	½ tsp	1 tsp
		Ginger-Garlic Paste	1 tsp	1 tsp	1½ tsp
		Green Chilli Paste	1 tsp	1 tsp	1½ tsp
		Bay Leaves	2	3	4
		Cumin Seeds	1 tsp	1 tsp	1½ tsp
		Garam Masala Powder	1 tsp	2 tsp	2½ tsp
		Butter As Required			
		Coriander Leaves For Garnish			
		Salt To Taste			
		Method of preparation:			
		Prepare tadka in a microwave oven safe bowl as explained in Insta 3 with all the ingredients other than paneer, spinach paste, and salt. Remove, add the remaining ingredients and mix well. Place the bowl in the microwave oven, select Insta 1, enter weight and press start. Remove, garnish with coriander and serve.			

FISH CURRY	Insta 1	FISH CURRY	230gms	460gms	690gms
		Ingredients:			
		Fish - Washed & Sliced	230 gms	460 gms	690 gms
		Coriander Leaves – Chopped	1 tbsp	1½ tbsp	2 tbsp
		Tomatoes - Finely Chopped	2	2	3
		Garlic Cloves	5	6	7
		Green Chillies – Chopped	2	3	4
		Methi Seeds	1 tsp	1½ tsp	2 tsp
		Coriander Powder	1 tsp	1½ tsp	1½ tsp
		Turmeric Powder	¼ tsp	½ tsp	½ tsp
		Salt To Taste			
		Oil As Required			
		Method of preparation:			
		Marinate the fish in salt and turmeric powder for 15 minutes. Grind the coriander leaves, garlic and green chillies into a paste. Prepare tadka as explained in Insta 3 with all the ingredients other than the fish and above mentioned paste. Remove, add fish & coriander, green chilli, garlic paste to the tadka and mix smoothly. Place the bowl in the microwave oven, select Insta 1, enter weight and press start. Remove and serve hot.			

PANEER BHURJI	Insta 1	PANEER BHURJI	230gms	460gms	690gms
		Ingredients:			
		Paneer Grated	230 gms	460 gms	690 gms
		Tomatoes	2	3	4
		Oil	½ tbsp	1 tbsp	1tbsp
		Cumin Seeds	½ tsp	1 tsp	1 tsp
		Green Chillies	3	4	4
		Onion Chopped	2	3	3
		Turmeric Powder	¼ tsp	½ tsp	½ tsp
		Garam Masala Powder	1 tsp	1½ tsp	2 tsp
		Ginger-Garlic Paste	1 tsp	1½ tsp	1½ tsp
		Salt To Taste			
		Method of preparation			
		Prepare tadka in a microwave oven safe bowl as explained in Insta 3 with all the ingredients other than grated paneer and salt. After beep, remove and add grated paneer, salt, mix well and select Insta 1, enter weight, press start. Serve hot.			

BAINGAN MASALA	Insta 1	BAINGAN MASALA			
		Ingredients:			
		brinjal (baingan), cut into half	230 gms	460 gms	690 gms
		tomatoes, chopped	2	3	4
		onions, chopped	1	2	2
		methi leaves (fenugreek)	½ cup	¾ cup	1 cup
		garlic paste	½ tsp	¾ tsp	1 tsp
		cumin seeds	1 tsp	1½ tsp	2 tsp
		curry leaves	few	few	few
		turmeric powder	¼ tsp	¼ tsp	½ tsp
		red chili powder	1½ tsp	2 tsp	3 tsp
		oil as required			
		coriander for garnish			
		salt & pepper to taste			
		Method of preparation			
		Prepare tadka in a microwave oven safe bowl as explained in Insta 3 with all the ingredients other than tomato, methi leaves, venigar, salt and pepper. After beep, Remove, add the remaining ingredients and mix well. Place the bowl in the microwave oven, select Insta 1, enter weight and press start. Remove, garnish with coriander and serve.			

KARELA FRY	Insta 1	KARELA FRY	230gms	460gms	690gms
		Ingredients:			
		Karela (Cut Into Thin Round)	230 gms	460 gms	690 gms
		Lemon Juice	1½ tsp	2 tsp	3 tsp
		Turmeric Powder	½ tsp	¾ tsp	¾ tsp
		Red Chilli Powder	1 tsp	1½ tsp	2 tsp
		Jeera Powder	1 tsp	1½ tsp	2 tsp
		Garam Masala	1 tsp	1½ tsp	2 tsp
		Oil As Required			
		Salt To Taste			
		Method of preparation			
		Marinate karela with the lemon juice, turmeric, salt for 20 minutes and wash it well. Prepare tadka in a microwave oven safe bowl as explained in Insta 3 with all the ingredients other than garam masala. After beep, remove, add the remaining ingredients, mix well. Place the bowl in the microwave oven, select Insta 1, enter weight and press start.			

CARROT CURRY	Insta 1	CARROT CURRY	230gms	460gms	690gms
		Ingredients:			
		Carrots Chopped	230 gms	460 gms	690 gms
		Roasted Sesame Seeds Paste	¾ cup	1 cup	1½ cup
		Dried Red Chillies	2	3	4
		Red Chilli Powder	1½ tsp	2 tsp	3 tsp
		Turmeric Powder	¼ tsp	¼ tsp	½ tsp
		Mustard Seeds	½ tsp	¾ tsp	1 tsp
		Cumin Seeds	½ tsp	¾ tsp	1 tsp
		Urad Dal	1½ tsp	2 tsp	3 tsp
		Curry Leaves	few	few	few
		Oil As Required			
		Salt To Taste			
		Coriander For Garnish			
		Method of preparation			
		Prepare tadka in a microwave oven safe bowl as explained in Insta 3 with all the ingredients other than carrots and salt. After beep, remove and add the remaining ingredients, mix well. Place the bowl in the microwave oven, select Insta 1, enter weight and press start. Remove, garnish with coriander and serve.			

CARROT SOUP	Insta 1	CARROT SOUP	230gms	460gms	690gms
		Ingredients:			
		Carrot – Chopped	150 gms	300 gms	500 gms
		Sweet Potato – Chopped	80 gms	160 gms	190 gms
		Onion – Chopped	1 cup	1½ cup	1½ cup
		Vegetable Broth	1 cup	1½ cup	1½ cup
		Coconut Milk	1 cup	1½ cup	1½ cup
		Ginger Sliced	½ tsp	½ tsp	1 tsp
		Garlic Chopped	½ tsp	½ tsp	1 tsp
		Curry Powder	½ tsp	½ tsp	1 tsp
		Pepper Powder	1 tsp	1 tsp	1½ tsp
		Salt To Taste			
		Method of preparation;			
		Prepare tadka in a microwave oven safe bowl as explained in Insta 3 with all the ingredients other than carrots, sweet potato, vegetable broth and coconut milk, After beep, remove, add the remaining ingredients, mix well. Place the bowl in the microwave oven, select Insta 1, enter weight and press start. Remove, allow it to cool and blend in a juicer. Drain, reheat and serve.			

TOMATO CHUTNEY	Insta 1	TOMATO CHUTNEY	230gms	460gms	690gms
		Ingredients:			
		Tomatoes – Chopped	100 gms	200 gms	400 gms
		Onion - Large Chopped	1	1	2
		Garlic – Chopped	½ tsp	½ tsp	1 tsp
		Red Chilli Powder	1 tsp	1 tsp	1½ tsp
		Tamarind Extract (Juice)	½ cup	½ cup	1 cup
		Oil As Required			
		Salt To Taste			
		For seasoning:			
		Oil As Required			
		Curry Leaves As Required			
		Mustard Seeds As Required			
		Pinch Of Asafetida Powder			
		Method of preparation;			
		Take a microwave oven safe bowl; add oil, onion, garlic, salt, tomatoes, red chilli powder, and tamarind juice and mix well. Place the bowl in the microwave oven, select Insta 1, enter weight and press start. Remove and allow to cool grind into a fine paste. Take a microwave oven safe bowl; add the ingredients for seasoning and place it in the microwave oven. Select Insta 3, enter weight and press start. Remove, add to the tomato mixture, mix well and serve.			

PRAWNS MASALA	Insta 1	PRAWNS MASALA	230gms	460gms	690gms
		Ingredients:			
		Prawn – Shelled	230 gms	460 gms	690 gms
		Onions Cut Into Small Pieces	1	2	3
		Garlic Paste	¼ tsp	½ tsp	1 tsp
		Ginger Paste	¼ tsp	½ tsp	1 tsp
		Chilli Powder	1 tsp	1½ tsp	2 tsp
		Turmeric Powder	¼ tsp	¼ tsp	½ tsp
		Mustard Seeds	¼ tsp	½ tsp	1 tsp
		Oil As Required			
		Salt To Taste			
		Method of preparation;			
		Prepare tadka in a microwave oven safe glass bowl as explained in Insta 3 with all the ingredients other than the prawns. Remove, add the prawns and mix well. Place the bowl in the microwave oven, select Insta 1, enter weight and press start. Remove and serve hot.			

MUSHROOM SOUP	Insta 1	MUSHROOM SOUP	230gms	460gms	690gms
		Ingredients:			
		Button Mushrooms	230 gms	460 gms	690 gms
		Chicken Stock	1 cup	1½ cup	2 cup
		Spring Onions, Chopped Finely	½ tbsp	½ tbsp	1 tbsp
		Ginger Paste	½ tsp	½ tsp	1 tsp
		Black Peppers	few	few	few
		Salt To Taste			
Method of preparation;					
Prepare tadka in a microwave oven safe glass bowl as explained in Insta 3, with all the ingredients other than mushrooms and salt. Remove, add all remaining ingredients and mix well. Place the bowl in the microwave oven, select Insta 1, enter weight and press start. Remove and serve.					

PUDINA CHUTNEY	Insta 1	PUDINA CHUTNEY	230gms	460gms	690gms
		Ingredients:			
		Pudina Leaves	230 gms	460 gms	690 gms
		Raw Mango Peeled, Chopped	1 cup	1½ cup	2 cup
		Sesame Seeds	½ cup	½ cup	1 cup
		Green Chillies / Red Chillies	3	4	5
		Mustard Seeds	1 tsp	1 tsp	1 tsp
		Cumin Seeds	1 tsp	1 tsp	1 tsp
		Chana Dal, Soaked	½ tbsp	½ tbsp	1 tbsp
		Asafetida	a pinch	a pinch	a pinch
		Oil As Required			
		Salt To Taste			
Method of preparation;					
Prepare tadka in a microwave oven safe glass bowl as explained in Insta 3, with all the ingredients other than raw mango, pudina leaves, salt. Remove, add all remaining ingredients and mix well. Place the bowl in the microwave oven, select Insta 1, enter weight and press start. Remove and serve.					

BUTTER CHICKEN	Insta 1	BUTTER CHICKEN	230gms	460gms	690gms
		Ingredients:			
		Boneless Chicken	230 gms	460 gms	690 gms
		Yogurt	1½ tbsp	2 tbsp	3 tbsp
		Lime Juice	¾ tsp	1 tsp	1½ tsp
		Red Chilli Powder	1½ tsp	2 tsp	3 tsp
		Roasted Cloves	3	4	6
		Roasted Pepper Corns	3	4	6
		Roasted Cinnamon	¾ inch	1 inch	1 inch
		Cardamom	3	4	6
		Roasted Almonds	4	5	6
		Bay Leaves	2	2	3
		Oil	½ tbsp	¾ tbsp	1 tbsp
		Chopped Onions	2	2	3
		Garlic Paste	¾ tsp	1 tsp	1 tsp
		Ginger Paste	¾ tsp	1 tsp	1 tsp
		Coriander Powder	¾ tsp	1 tsp	1 tsp
		Cumin Powder	¾ tsp	1 tsp	1 tsp
		Turmeric Powder	¼ tsp	½ tsp	½ tsp
		Tomato Puree	1½ tbsp	2 tbsp	3 tbsp
		Chicken Stock	2 cup	2 cup	2 cup
		Kasuri Methi	1½ tsp	2 tsp	2 tsp
		Butter As Required			
		Salt To Taste			
		Coriander Leaves For Garnish			
		Method of preparation;			
		Grind & make a paste of cloves, pepper corns, cinnamon, almonds & cardamom. Marinate the chicken with the above paste and butter, yogurt, salt, lime juice, red chilli powder, bay leaves, coriander, cumin, turmeric powder & set aside for 1 hour. Prepare tadka in a microwave oven safe bowl as explained in Insta 3 with oil, onion, garlic, ginger paste and marinated chicken. Remove, add the remaining ingredients and mix well. Place the bowl in the microwave oven, select Insta 1, enter weight and press start. Remove and garnish with coriander leaves and serve.			

BHENDI FRY	Insta 1	BHENDI FRY	230gms	460gms	690gms
		Ingredients:			
		Lady Finger	230 gms	460 gms	690 gms
		Gram Flour	½ cup	1 cup	1½ cup
		Sliced Onion	½ cup	1 cup	1½ cup
		Sliced Green Chilli	2	3	4
		Coriander Powder	½ tsp	1 tsp	1½ tsp
		Red Chilli Powder	1 tsp	1½ tsp	2 tsp
		Garam Masala Powder	1 tsp	1½ tsp	2 tsp
		Cumin Seeds	½ tsp	1 tsp	1½ tsp
		Turmeric Powder	¼ tsp	¼ tsp	½ tsp
		Oil As Required			
		Salt To Taste			
Method of preparation;					
Prepare tadka in a microwave oven safe glass bowl as explained in Insta 3 with all the ingredients other than lady finger. Remove, add lady fingers and mix well. Place the bowl in the microwave oven, select Insta 1, enter weight and press start. Remove and serve.					

MUTTON LIVER CURRY	Insta 1	MUTTON LIVER CURRY	230gms	460gms	690gms
		Ingredients:			
		Goat Liver	230 gms	460 gms	690 gms
		Onion Finely Sliced	1	2	3
		Ginger & Garlic Paste	½ tsp	1 tsp	1½ tsp
		Tomato Puree	½ cup	½ cup	1 cup
		Turmeric	¼ tsp	¼ tsp	½ tsp
		Red Chilli Powder	1 tsp	1½ tsp	2 tsp
		Coriander Powder	1 tsp	1½ tsp	2 tsp
		Cumin Powder	1 tsp	1½ tsp	2 tsp
		Garam Masala Powder	1 tsp	1½ tsp	2 tsp
		Ghee	½ tbsp	½ tbsp	1 tbsp
		Bay Leaves	2	3	4
		Cinnamon	1" stick	2" stick	3" stick
		Green Cardamom	3	4	6
		Cloves	3	4	6
		Coriander Leaves For Garnish			
		Water As Required			
		Salt To Taste			
Method of preparation;					
Prepare tadka in a microwave oven safe glass bowl as explained in Insta 3 with all the ingredients other than liver, tomato puree, coriander leaves and water. Remove, add the remaining ingredients other than coriander leaf and mix well. Place the bowl in the microwave oven, select Insta 1, enter weight and press start. Remove, garnish with coriander leaves and serve.					

METHI MALAI MATAR	Insta 1	METHI MALAI MATAR	230gms	460gms	690gms
		Ingredients:			
		Methi Leaves	50 gms	100 gms	150 gms
		Green Peas	200 gms	300 gms	350 gms
		Malai / Cream	50 gms	100 gms	150 gms
		Onion Paste	50 gms	100 gms	150 gms
		Green Chilli Paste	1 tsp	1½ tsp	2 tsp
		Garlic, Ginger Paste	½ tsp	½ tsp	1 tsp
		Khus Khus Paste	½ tbsps	½ tbsps	1 tbsps
		Cumins	½ tsp	½ tsp	1 tsp
		Cashew Nuts	4	5	6
		Milk	1 cup	1½ cup	2 cup
		Oil As Required			
		Salt To Taste			
		Method of preparation:			
		Prepare tadka as explained in Insta 3 in a microwave oven safe glass bowl with all the ingredients other than methi leaves, green peas, malai and milk. Remove; add methi leaves, green peas, malai, and milk and mix well. Cover the bowl with lid and place it in the microwave oven. Select Insta 1, enter weight and press start. Remove and serve.			

GREEN PEAS CURRY	Insta 1	GREEN PEAS CURRY	230gms	460gms	690gms
		Ingredients:			
		Green Peas	230 gms	460 gms	690 gms
		Tomato	1	2	2
		Onions	1	2	2
		Ginger, Garlic Paste	1 tsp	1½ tsp	2 tsp
		Green Chillies	1	2	2
		Turmeric Powder	¼ tsp	¼ tsp	½ tsp
		Coriander Leaves	few	few	few
		Garam Masala Powder	1 tsp	1½ tsp	2 tsp
		Coriander Powder	¼ tsp	¼ tsp	½ tsp
		Chilly Powder	1 tsp	1½ tsp	2 tsp
		Mustard Seeds	¼ tsp	¼ tsp	½ tsp
		Black Pepper Powder	¼ tsp	¼ tsp	½ tsp
		Coconut Milk	½ cup	½ cup	1 cup
		Curry Leaves	few	few	few
		Oil As Required			
		Salt To Taste.			
		Method of preparation;			
		Prepare tadka in a microwave oven safe glass bowl as explained in Insta 3 with all the ingredients other than tomato, green peas and coconut milk. After beep, remove; add the remaining ingredients mix well. Place the bowl in the microwave oven, select Insta 1, enter weight and press start.			

GRATED RADISH CURRY	Insta 1	GRATED RADISH CURRY	230gms	460gms	690gms
		Ingredients:			
		Radish (Grated)	230 gms	460 gms	690 gms
		Coconut (Grated)	1 cup	1½ cup	2 cup
		Onion Chopped	1 cup	1½ cup	2 cup
		Chilli Powder	1½ tsp	2 tsp	3 tsp
		Chopped Green Chillies	3	4	5
		Turmeric Powder	¼ tsp	½ tsp	½ tsp
		Mustard Seeds	½ tsp	1 tsp	1 tsp
		Curry Leaves	few	few	few
		Oil As Required			
		Salt To Taste			
		Coriander Leaves For Garnish			
		Method of preparation:			
		Prepare tadka as explained in Insta 3 in a microwave oven safe glass bowl with all the ingredients other than grated radish, grated coconut and coriander leaves. Remove; add all remaining ingredients other than coriander leaves and mix well. Cover the bowl with lid and place it in the microwave oven. Select Insta 1, enter weight and press start. Remove, garnish with coriander leaves and serve.			

GOBI MATAR	Insta 1	GOBI MATAR	230gms	460gms	690gms
		Ingredients:			
		Cauliflower Florets	50 gms	100 gms	150 gms
		Green Peas	100 gms	160 gms	200 gms
		Lauki	50 gms	100 gms	150 gms
		Chopped Cabbage	30 gms	100 gms	190 gms
		Green Chillies	2	3	4
		Cashew Nut Paste	½ cup	¾ cup	1 cup
		Garam Masala	1½ tsp	2 tsp	3 tsp
		Curd	1 cup	1½ cup	2 cup
		Oil As Required			
		Method of preparation:			
		Prepare tadka as explained in Insta 3 in a microwave oven safe glass bowl with all the ingredients other than Lauki, cabbage, green peas and curd, After the beep, remove and add all remaining ingredients, mix well. Place the bowl in the microwave oven. Select Insta 1, enter weight and press start. Serve hot.			

CAULIFLOWER ONION FRY	Insta 1	CAULIFLOWER ONION FRY	230gms	460gms	690gms
		Ingredients:			
		Cauliflower Florets	230 gms	460 gms	690 gms
		Onion Chopped	1	2	3
		Green Chillies	2	3	4
		Coriander Powder	2 tsp	3 tsp	4 tsp
		Lemon Juice	1 tsp	2 tsp	2 tsp
		Turmeric Powder	¼ tsp	¼ tsp	½ tsp
		Mustard Seeds	¼ tsp	½ tsp	½ tsp
		Cumin Seeds	½ tsp	1 tsp	1 tsp
		Curry Leaves	few	few	few
		Oil As Required			
		Salt To Taste			
		Method of preparation:			
		Prepare tadka as explained in Insta 3 in a microwave oven safe glass bowl with all the ingredients other than cauliflower florets and salt. After the beep, remove and add all remaining ingredients, mix well. Place the bowl in the microwave oven. Select Insta 1, enter weight and press start. Serve hot.			

ALOO MATAR	Insta 1	ALOO MATAR	230gms	460gms	690gms
		Ingredients:			
		Potatoes	130 gms	260 gms	390 gms
		Green Peas	100 gms	200 gms	300 gms
		Curd	1 cup	1½ cup	2 cup
		Green Chillies	2	2	3
		Turmeric Powder	¼ tsp	¼ tsp	½ tsp
		Onion	1	2	3
		Tomatoes Puree	1 cup	1½ cup	2 cup
		Ginger	½ tsp	½ tsp	1 tsp
		Coriander Powder	½ tsp	½ tsp	1 tsp
		Red Chilli Powder	1 tsp	1 tsp	1½ tsp
		Garam Masala	1 tsp	1 tsp	1½ tsp
		Oil As Required			
		Salt To Taste			
		Coriander Leaves For Garnish			
		Method of preparation:			
		Prepare tadka in a microwave oven safe glass bowl as explained in Insta 3, with all the ingredients other than tomato puree, salt, green peas, and curd. Remove, add all remaining ingredients and mix well. Place the bowl in the microwave oven, select Insta 1, enter weight and press start. Remove, garnish with coriander leaves and serve.			

COCONUT PAYASAM	Insta 1	COCONUT PAYASAM	230gms	460gms	690gms	
	Ingredients:					
	Grated Coconut		2 cup	3 cup	4 cup	
	Jaggery		1 cup	1½ cup	2 cup	
	Milk		1 cup	1½ cup	2 cup	
	Ghee		3 tsp	4 tsp	5 tsp	
	Roasted Cashew Nuts		6	8	10	
	Cardamom Powder		a pinch	a pinch	a pinch	
	Method of preparation:					
	Grind coconut and squeeze milk from it 2 times. Take a microwave oven safe bowl; add ghee, coconut milk, jaggery and milk, cardamom powder, mix well. Place the bowl in microwave oven select Insta 1, set weight, press start. After beep, remove and add cashew. Serve hot.					

SWEET POTATO SOUP	Insta 1	SWEET POTATO SOUP	230gms	460gms	690gms
	Ingredients:				
	Sweet Potato Chopped		230 gms	460 gms	690 gms
	Onion Chopped		1	2	3
	Nutmeg Powder		a pinch	a pinch	a pinch
	Black Pepper Powder		a pinch	a pinch	a pinch
	Milk Or Heavy Cream		1 cup	1½ cup	2 cup
	Corn Flour		1 tbsp	1½ tbsp	2 tbsp
	Vegetable Stock		1 cup	1½ cup	2 cup
	Lemon Juice		1 tsp	1 tsp	1½ tsp
	Butter		1 tbsp	1½ tbsp	2 tbsp
	Salt To Taste				
	Method of preparation:				
Prepare tadka as explained in Insta 3 in a microwave oven safe bowl with all the ingredients other than nutmeg powder, pepper powder, milk, vegetable stock and lemon juice. After the beep, remove and add all remaining ingredients, mix well. Place the bowl in the microwave oven. Select Insta 1, enter weight and press start. Remove and make puree of the sweet potato mixture. Serve hot.					

ARBI/ TARO ROOT FRY	Insta 1	ARBI/ TARO ROOT FRY	230gms	460gms	690gms
		Ingredients:			
		Taro Root (Boiled & Peeled)	230 gms	460 gms	690 gms
		Roasted Dalia Powder	1 cup	1½ cup	2 cup
		Red Chilli Powder	1 tsp	1 tsp	1½ tsp
		Turmeric Powder	a pinch	a pinch	a pinch
		Mustard Seeds	½ tsp	½ tsp	1 tsp
		Cumin Seeds	1 tsp	1 tsp	1½ tsp
		Urad Dal	3 tsp	4 tsp	5 tsp
		Curry Leaves	few	few	few
		Oil As Required			
		Salt To Taste			
		Method of preparation:			
		Prepare tadka as explained in Insta 3 in a microwave oven safe bowl with all the ingredients other than taro root and salt. After the beep, remove and add all remaining ingredients, mix well. Place the bowl in the microwave oven. Select Insta 1, enter weight and press start. Serve hot.			

TINDORA FRY	Insta 1	TINDORA FRY	230gms	460gms	690gms
		Ingredients:			
		Tindora Chopped	230 gms	460 gms	690 gms
		Roasted Dalia Powder	1 cup	1½ cup	2 cup
		Ajwain	1 tsp	1 tsp	1½ tsp
		Red Chilli Powder	1 tsp	1½ tsp	2 tsp
		Turmeric Powder	a pinch	a pinch	a pinch
		Mustard Seeds	½ tsp	½ tsp	1 tsp
		Cumin Seeds	1 tsp	1½ tsp	2 tsp
		Curry Leaves	few	few	few
		Oil As Required			
		Salt To Taste			
		Method of preparation:			
		Prepare tadka as explained in Insta 3 in a microwave oven safe bowl with all the ingredients other than tindora and salt. After the beep, remove and add all remaining ingredients, mix well. Place the bowl in the microwave oven. Select Insta 1, enter weight and press start. Serve hot.			

CAPSICUM WITH PEANUTS	Insta 1	CAPSICUM WITH PEANUTS	230gms	460gms	690gms	
		Ingredients:				
		Capsicum	230 gms	460 gms	690 gms	
		Raw Peanuts Powder	2 tbsp	3 tbsp	4 tbsp	
		Urad Dal	1 Tbsp	2 tbsp	3 tbsp	
		Whole Red Chilli	3	4	5	
		Tamarind (Optional)	1" piece	2 " piece	3" piece	
		Mustard Seeds	½ tsp	½ tsp	1 tsp	
		Cumin Seeds	½ tsp	1 tsp	1½ tsp	
		Urad Dal	1 tsp	1½ tsp	2 tsp	
		Curry Leaves	few	few	few	
		Oil As Required				
		Salt To Taste				
		Method of preparation;				
		Prepare tadka in a microwave oven safe glass bowl as explained in Insta 3 with all the ingredients other than capsicum and tamarind, after beep. Remove, add the remaining ingredients and mix well. Place the bowl in the microwave oven, select Insta 1, enter weight and press start. Serve hot.				

SARSON KA SAAG	Insta 1	SARSON KA SAAG	230gms	460gms	690gms
		Ingredients:			
		Spinach Chopped	100 gms	200 gms	300 gms
		Mustard Greens Chopped	130 gms	260 gms	390 gms
		Green Chillies	2	3	4
		Ginger Paste	½ tsp	½ tsp	1 tsp
		Garlic Paste	½ tsp	½ tsp	1 tsp
		Onion Grated	½ cup	1 cup	1½ cup
		Coriander Powder	1 tsp	1½ tsp	2 tsp
		Cumin Powder	1 tsp	1½ tsp	2 tsp
		Garam Masala Powder	1½ tsp	2 tsp	3 tsp
		Lime Juice	1 tsp	1½ tsp	2 tsp
		Bengal Gram Flour	1 tbsp	1½ tbsp	2 tbsp
		Ghee As Required			
		Salt To Taste			
	Method of preparation:				
	Make a paste of spinach, mustard green, green chillies and salt. Set aside. Prepare tadka as explained in Insta 3 in a microwave oven safe bowl with all the ingredients other than green paste, lime juice and bengal gram flour. After the beep, remove and add all remaining ingredients, mix well. Place the bowl in the microwave oven. Select Insta 1, enter weight and press start. Serve hot.				

MACHER JHOL	Insta 1	MACHER JHOL	230gms	460gms	690gms
		Ingredients:			
		Fish Rohu	230 gms	460 gms	690 gms
		Potatoes	2	4	6
		Onion Paste	½ cup	1 cup	1½ cup
		Green Chillies	2	3	4
		Coriander Seeds	1 tsp	1½ tsp	2 tsp
		Cumin Seeds	1 tsp	1½ tsp	2 tsp
		Turmeric Powder	¼ tsp	¼ tsp	½ tsp
		Chilli Powder	1 tsp	1½ tsp	2 tsp
		Oil			
		Salt To Taste			
Method of preparation:					
Marinate fish with turmeric powder and salt for 20 minutes and wash it well. Prepare tadka in a microwave oven safe bowl as explained in Insta 3 with all the ingredients other than fish. After beep, remove, add the remaining ingredients, mix smoothly. Place the bowl in the microwave oven, select Insta 1, enter weight and press start.					

MISA MACH PORA	Insta 1	MISA MACH PORA	230gms	460gms	690gms
		Ingredients:			
		Shrimps, Shelled	2 cup	3 cup	4 cup
		Ground Coriander	1½ tsp	2 tsp	3 tsp
		Lime Juice	2 tsp	3 tsp	3 tsp
		Onion, Chopped	½ cup	1 cup	1½ cup
		Peppercorns	few	few	few
		Turmeric Powder	a pinch	a pinch	a pinch
		Salt To Taste			
		Oil As Required			
Method of preparation:					
Rub salt and turmeric powder on the shelled shrimps. Marinate for 20 minutes. Prepare tadka as explained in Insta 3 in a microwave oven safe bowl with all the ingredients other than marinated shrimps and lime juice. After the beep, remove and add all remaining ingredients, mix well. Place the bowl in the microwave oven. Select Insta 1, enter weight and press start. Serve hot.					

CHICKEN XACUTI	Insta 1	CHICKEN XACUTI	230gms	460gms	690gms	
		Ingredients:				
		Chicken	230 gms	460 gms	690 gms	
		Small Potatoes	few	few	few	
		Small Onions	few	few	few	
		Nutmeg Powder	¼ tsp	¼ tsp	½ tsp	
		Coconut Paste	½ cup	1 cup	1½ cup	
		Xacuti Masala Ingredients:				
		Red Chillies	4	5	6	
		Coconut Pieces	few	few	few	
		Cloves	2	3	4	
		Turmeric Powder	¼ tsp	¼ tsp	½ tsp	
		Pepper Corns	few	few	few	
		Jeera	½ tsp	½ tsp	1 tsp	
		Methi Seeds	½ tsp	½ tsp	1 tsp	
		Saunf	1½ tsp	2 tsp	3 tsp	
		Garlic Flakes	3	4	5	
		Ginger	¼ " inch	½ " inch	1 " inch	
		Cinnamon	¼ " inch	½ " inch	1 " inch	
		Khus Khus	½ cup	1 cup	1½ cup	
		Coriander Seeds	1½ tsp	2 tsp	3 tsp	
		Sesame seeds	1½ tsp	2 tsp	3 tsp	
		Onion	1	2	2	
		Method of preparation:				
		Make a fine paste of all masala ingredients. Prepare tadka as explained in Insta 3 in a microwave oven safe bowl with all the ingredients other than chicken and potato. After the beep, remove and add all remaining ingredients, mix well. Place the bowl in the microwave oven. Select Insta 1, enter weight and press start. Serve hot.				

PLAIN PALAK CURRY	Insta 1	PLAIN PALAK CURRY	230gms	460gms	690gms
		Ingredients:			
		Palak (Spinach) Finely Chopped	2 cup	2½ cup	3 cups
		Red Chilly Powder	1 tsp	1 tsp	1 tsp
		Moong Dal	¼ cup	½ cup	¾ cup
		Garam Masala	1 tsp	1 tsp	1 tsp
		Turmeric Powder	¼ tsp	¼ tsp	½ tsp
		Garlic Paste	¼ tsp	¼ tsp	½ tsp
		Ginger Paste	¼ tsp	¼ tsp	½ tsp
		Oil As Required			
		Salt To Taste			
		Method of preparation			
		Prepare tadka in a microwave oven safe bowl as explained in Insta 3 with all the ingredients other than palak and salt. After beep, remove, add the remaining ingredients and mix well. Place the bowl in the microwave oven, select Insta 1, enter weight and press start. Remove and serve hot.			

MACHE BESARA	Insta 1	MACHE BESARA	230gms	460gms	690gms
		Ingredients:			
		fish (rohu or any fresh water fish)	230gms	460gms	690gms
		potato (cut into cubes)	1	2	2
		curd	1cup	2 cup	2 cup
		green chillies paste	4	5	6
		mustard paste	1tbsp	1½ tbsp	2 tbsp
		garlic cloves paste	2	3	4
		turmeric powder	¼ tsp	½ tsp	¾ tsp
		cumin seeds	1 tsp	1½ tsp	2 tsp
		mustard seeds	1 tbsp	1 tbsp	1½ tbsp
		fennel seeds	1 tsp	1½ tsp	2 tsp
		fenugreek seeds	1 tsp	1½ tsp	2 tsp
		kale jeera seeds	1 tsp	1½ tsp	2 tsp
		oil as required			
		salt to taste			
		coriander leaves for garnish			
		Method of preparation			
		Prepare tadka in a microwave oven safe bowl as explained in Insta 3 with all the ingredients other than fish, curd and coriander leaves. After beep, remove; add all the ingredients other than coriander leaves and mix smoothly. Place the bowl in the microwave oven selects Insta 1, enter weight and press start. Remove, garnish with coriander leaves and serve hot.			

CHICKEN CHETTINAD	Insta 1	CHICKEN CHETTINAD	230gms	460gms	690gms
		Ingredients:			
		Chicken	230 gms	460 gms	690 gms
		Khus Khus Roasted	1 tbsp	1½ tbsp	2 tbsp
		Dry Red Chillies Roasted	3	4	5
		Coriander Roasted	½ tsp	¾ tsp	1tsp
		Mustard Roasted	½ tbsp	¾ tbsp	1tbsp
		Cinnamon Roasted	½ inch	½ inch	1 inch
		Cardamom Roasted	2	3	4
		Cloves Roasted	2	3	4
		Chilli Powder	1 tsp	1½ tsp	2 tsp
		Turmeric Powder	½ tsp	¾ tsp	1 tsp
		Chopped Ginger	1 tsp	1tsp	1tsp
		Chopped Garlic	1 tsp	1 tsp	1½ tsp
		Chopped Tomato	1	1½	2
		Chopped Onions	1	1½	2
		Oil	1 tbsp	1 tbsp	1½ tbsp
		Curry Leaves	few	few	few
		Lemon Juice	½ tsp	¾ tsp	1 tsp
		Sugar	½ tsp	¾ tsp	1 tsp
		Grated Coconut for Garnish			
		Coriander Leaves for Garnish			
		Salt To Taste			
Method of preparation;					
In a mixer, grind all the roasted ingredients with garlic and ginger to make a uniform paste. Prepare tadka in a microwave oven safe bowl as explained in Insta 3, with all the ingredients other than chicken, tomato, coconut and coriander leaves. After beep, remove, add the remaining ingredients except coconut and coriander leaf and mix well. Place the bowl in the microwave oven, select Insta 1, enter weight and press start. Remove, garnish with coconut and coriander. Serve hot.					

PANEER MAKHANI	Insta 1	PANEER MAKHANI	230gms	460gms	690gms
		Ingredients:			
		Paneer	230 gms	460 gms	690 gms
		Tomato Puree	1 cup	1½ cup	2 cup
		Fresh Cream	1 cup	1½ cup	2 cup
		Green Chillies	1	2	3
		Red Chilli Powder	1 tsp	1 tsp	1½ tsp
		Garam Masala Powder	1 tsp	1 tsp	1½ tsp
		Dried Kasuri Methi	few	few	few
		Butter As Required			
		Salt To Taste			
		Method of preparation;			
		Prepare tadka in a microwave oven safe bowl as explained in Insta 3 with all the ingredients other than tomato puree and fresh cream. After beep, remove, add the remaining ingredients and mix well. Place the bowl in the microwave oven, select Insta 1, enter weight and press start. Remove, and serve hot.			

COCONUT LADOO	Insta 1	COCONUT LADOO	230gms	460gms	690gms
		Ingredients:			
		Suji / Rava	1 cup	2 cup	3 cup
		Grated Coconut	1½ cup	3 cup	4 cup
		Condensed Milk	as required	as required	as required
		Powdered Sugar	1 cup	2 cup	3 cup
		Dry Coconut Powder	½ cup	¾ cup	1 cup
		Method of preparation;			
		Take suji (rava) in a microwave oven safe glass bowl. Place in the microwave oven, select Insta 3, enter weight & press start. After beep, remove, add grated coconut, condensed milk, powdered sugar & mix well. Select Insta 1, enter weight, and press start. Remove after beep & set aside to cool. Make small balls of the mixture. Roll the balls in dry coconut powder & serve.			

BANANA HALWA	Insta 1	BANANA HALWA	230gms	460gms	690gms
		Ingredients:			
		Banana Ground To Paste	2 cup	2½ cup	3 cups
		Wheat Flour	¾ cup	1 cup	1½ cup
		Milk	¾ cup	1 cup	1½ cup
		Cardamom Powder	a pinch	a pinch	a pinch
		Sugar	1 cup	1½ cup	2 cup
		Cashews	few	few	few
		Almonds	few	few	few
		Ghee As Required			
		Method of preparation			
		Prepare tadka in a microwave oven safe bowl as explained in Insta 3 with wheat flour and ghee. After beep, remove, add the remaining ingredients and mix well. Place the bowl in the microwave oven, select Insta 1, enter weight and press start. Remove and serve hot.			

LOUKI SUBZI	Insta 1	LOUKI SUBZI	230gms	460gms	690gms
		Ingredients:			
		Lauki (Peel The Skin & Cut Into Pieces)	230 gms	460 gms	690 gms
		Peas	1 tbsp	1½ tbsp	2 tbsp
		Chopped Capsicum	1	1	1½
		Chopped Onion	1	2	2
		Chopped Green Chilli	2	2	3
		Yogurt	1 tbsp	1½ tbsp	2 tbsp
		Crushed Ginger	½ inch	¾ inch	1 inch
		Garam Masala	1 tsp	1½ tsp	2 tsp
		Turmeric Powder	½ tsp	¾ tsp	1 tsp
		Red Chilli Powder	1 tsp	1½ tsp	2 tsp
		Oil	1 tbsp	1 tbsp	1½ tbsp
		Chopped Coriander For Garnish			
		Salt To Taste			
		Water			
		Method of preparation			
		Prepare tadka in a microwave oven safe bowl as explained in Insta 3 with all the ingredients other than peas, capsicum, yogurt and coriander. After beep, remove, add the remaining ingredients other than coriander and mix well. Place the bowl in the microwave oven, select Insta 1, enter weight and press start. Remove and serve hot.			

PRAWNS VINDALOO	Insta 1	PRAWNS VINDALOO	230gms	460gms	690gms
		Ingredients:			
		Shelled Prawns	230 gms	460 gms	690 gms
		Tomatoes, Chopped	1 cup	1½ cup	2 cup
		Cumin Seeds	½ tsp	¾ tsp	1 tsp
		Ginger, Garlic Paste	1 tsp	1½ tsp	2 tsp
		Curry Leaves	few	few	few
		Chilli Powder	1 tsp	1½ tsp	2 tsp
		Turmeric Powder	¼ tsp	¼ tsp	½ tsp
		Vinegar	1 tbsp	1 tbsp	1½ tbsp
		Corn Flour	1 tbsp	1 tbsp	1½ tbsp
		Sugar	1 tsp	1½ tsp	2 tsp
		Salt To Taste			
		Method of preparation			
		Prepare tadka in a microwave oven safe bowl as explained in Insta 3 with all the ingredients other than prawns, tomato and vinegar. After beep, remove, add the remaining ingredients and mix well. Place the bowl in the microwave oven, select Insta 1, enter weight and press start. Remove and serve hot.			

CABBAGE CURRY	Insta 1	CABBAGE CURRY	230gms	460gms	690gms
		Ingredients:			
		Cabbage	230 gms	460 gms	690 gms
		Mixed Vegetables	1 cup	1½ cup	2 cup
		Cumin Seeds	½ tsp	¾ tsp	1 tsp
		Mustard Seeds	½ tsp	¾ tsp	1 tsp
		Turmeric Powder	¼ tsp	¼ tsp	½ tsp
		Urad Dal	1 tbsp	1 tbsp	1½ tbsp
		Green Chilly Chopped	3	5	6
		Oil As Required			
		Salt To Taste			
		Method of preparation			
		Prepare tadka in a microwave oven safe bowl as explained in Insta 3 with all the ingredients other than cabbage. After beep, remove, add the cabbage and mix well. Place the bowl in the microwave oven, select Insta 1, enter weight and press start. Remove, and serve hot.			

SEVIYA KHEER	Insta 1	SEVIYA KHEER	230gms	460gms	690gms
		Ingredients:			
		Seviya (Vermicelli) Roasted	2 cup	3 cup	4 cup
		Milk	4 cup	6 cup	8 cup
		Condensed Milk	1 cup	1½ cup	2 cup
		Sugar	1 cup	1½ cup	2 cup
		Raisins	½ tbsp	1 tbsp	1½ tbsp
		Cashew Nut Pieces (Roasted)	1 tbsp	1 tbsp	1½ tbsp
		Almonds (Roasted)	1tbsp	1tbsp	1½ tbsp
		Powdered Elaichi (Cardamom)	½ tsp	½ tsp	1 tsp
		Water As Required			
		Method of preparation			
		Take a microwave oven safe bowl; add all the ingredients except elaichi powder and raisins and mix well. Place the bowl in the microwave oven, select Insta 1, enter weight and press start. Remove; add elaichi powder and raisins mix well. Serve hot.			

DRUM STICK LEAVES CURRY	Insta 1	DRUMSTICK LEAVES CURRY	230gms	460gms	690gms
		Ingredients:			
		Drum Stick Leaves	2 cup	3 cup	4 cup
		Coconut Grated	1 tbsp	1 tbsp	1½ tbsp
		Masoor Dal	1 tbsp	1 tbsp	1½ tbsp
		Cumins Seeds	½ tsp	½ tsp	1 tsp
		Mustard Seeds	½ tsp	½ tsp	1 tsp
		Red Chilli Powder	1 tsp	1½ tsp	2 tsp
		Turmeric Powder	¼ tsp	¼ tsp	½ tsp
		Oil As Required			
		Salt To Taste			
		Method of preparation			
		Prepare tadka in a microwave oven safe bowl as explained in Insta 3 with all the ingredients other than drumstick leaves. After beep, remove, add the drumstick leaves and mix well. Place the bowl in the microwave oven, select Insta 1, enter weight and press start. Remove and serve hot.			

SHEERA	Insta 1	SHEERA	230gms	460gms	690gms
		Ingredients:			
		Suji - Roasted	1 cup	1½ cup	2 cup
		Milk	1 cup	1½ cup	2 cup
		Sugar	1 cup	1½ cup	2 cup
		Ghee	1 tbsp	1½ tbsp	2 tbsp
		Cardamom Powder	a pinch	a pinch	a pinch
		Cashews	4	5	6
		Almonds	4	5	6
		Raisins	few	few	few
		Water As Required			
		Method of preparation			
		Take a microwave oven safe bowl; add all ingredients and mix well. Place the bowl in the microwave oven, select Insta 1, enter weight and press start. Add water if required. Stir twice in between for better result. PN - Suji can be roasted by placing it on plain paper in the microwave oven and cooking it in microwave mode for 3 - 4 min. Mix twice in between			

TOMATO CURRY	Insta 1	TOMATO CURRY	230gms	460gms	690gms
		Ingredients:			
		Tomatoes, Finely Chopped	230 gms	460 gms	690 gms
		Red Chilli Powder	1 cup	1½ cup	2 cup
		Onions, Finely Chopped	1 cup	1½ cup	2 cup
		Garlic, Slightly Crushed	2	3	4
		Mustard Seeds	½ tsp	½ tsp	1 tsp
		Turmeric Powder	¼ tsp	¼ tsp	½ tsp
		Curry Leaves	few	few	few
		Jaggery	a pinch	a pinch	a pinch
		Coriander Powder	½ tsp	½ tsp	1 tsp
		Oil As Required			
		Salt To Taste			
		Coriander Leaves For Garnish			
Method of preparation					
Prepare tadka in a microwave oven safe bowl as explained in Insta 3 with all the ingredients other than tomatoes, jaggery and coriander leaves. After beep, remove, add all the ingredients other than coriander leave and mix well. Place the bowl in the microwave oven, select Insta 1, enter weight and press start. Remove and garnish with coriander leaves. Serve hot.					

TAMARIND RICE	Insta 1	TAMARIND RICE	230gms	460gms	690gms
		Ingredients:			
		Cooked Rice	1 cup	1½ cup	2 cup
		Tamarind Juice	¼ cup	½ cup	¾ cup
		Channa Dal	1 tsp	1½ tsp	2 tsp
		Dried Red Chilly	3	4	4
		Turmeric Powder	¼ tsp	½ tsp	¾ tsp
		Curry Leaves	few	few	Few
		Jaggery Powder	½ tsp	¾ tsp	1 tsp
		Fenugreek	½ tsp	¾ tsp	1 tsp
		Hing	a pinch	a pinch	a pinch
		Mustard	½ tsp	¾ tsp	1 tsp
		Sesame Oil	1 tbsp	1 tbsp	1½ tbsp
		Peanuts	few	few	Few
		Salt To Taste			
Method of preparation					
Prepare tadka in a microwave oven safe bowl as explained in Insta 3 with all the ingredients other than cooked rice and tamarind juice. After beep, remove, add the all ingredients and mix well. Place the bowl in the microwave oven, select Insta 1, enter weight and press start. Remove and serve hot.					

BABY CORN MASALA	Insta 1	BABY CORN MASALA	230gms	460gms	690gms
		Ingredients:			
		Baby Corn	230 gms	460 gms	690 gms
		Tomatoes Chopped	1 cup	1½ cup	2 cup
		Onion Chopped	1 cup	1½ cup	2 cup
		Roasted Groundnut Powder	¼ cup	½ cup	¾ cup
		Chilli Powder	1 tsp	1½ tsp	2 tsp
		Turmeric Powder	¼ tsp	¼ tsp	½ tsp
		Mustard Seeds	½ tsp	¾ tsp	1 tsp
		Cumin Seeds	1 tsp	1½ tsp	2 tsp
		Fenugreek Seeds	1 tsp	1½ tsp	2 tsp
		Saunf	1 tsp	1½ tsp	2 tsp
		Salt To Taste			
		Oil As Required			
		Coriander Leaves For Garnish			
Method of preparation					
Prepare tadka in a microwave oven safe bowl as explained in Insta 3 with all the ingredients other than baby corn, tomatoes and coriander leaves. After beep, remove, add the all ingredients other than coriander leaves and mix well. Place the bowl in the microwave oven, select Insta 1, enter weight and press start. Remove, garnish with coriander leaves and serve hot.					

BEEET ROOT RASAM	Insta 1	BEEET ROOT RASAM			
		Ingredients:			
		Beetroot chopped	230 gms	460 gms	690 gms
		Tamarind juice	1 cup	1½ cup	2 cup
		Urad Dal	1 tsp	1½ tsp	2 tsp
		Garlic paste	½ tsp	¾ tsp	1 tsp
		Cilantro Sprigs	¼ cup	½ cup	¾ cup
		Mustard Seeds	½ tsp	¾ tsp	1 tsp
		Cumin Seeds	½ tsp	¾ tsp	1 tsp
		Curry Leaves	few	few	few
		Oil as required			
		Salt to taste			
Method of preparation					
Prepare tadka in a microwave oven safe bowl as explained in Insta 3 with all the ingredients other than beetroot and tamarind juice. After beep, remove, add the all ingredients and mix well. Place the bowl in the microwave oven selects Insta 1, enter weight and press start. Remove, and serve hot.					

POTATO CURRY	Insta 1	POTATO CURRY			
		Ingredients:			
		Potato cut into cubes	2 cup	3 cup	4 cup
		Tomato puree	1 cup	1½ cup	2 cup
		Onion chopped	1 cup	1½ cup	2 cup
		Green Chile chopped	2	3	4
		Red Chile Powder	1 tsp	1½ tsp	2 tsp
		Turmeric Powder	¼ tsp	¼ tsp	½ tsp
		Mustard Seeds	½ tsp	¾ tsp	1 tsp
		Cumin Seeds	½ tsp	¾ tsp	1 tsp
		Curry leaves	few	few	few
		Salt to Taste			
		Oil as required			
		Method of preparation			
		Prepare tadka in a microwave oven safe bowl as explained in Insta 3 with all the ingredients other than potato and tomato puree. After beep, remove, add the all ingredients and mix well. Place the bowl in the microwave oven selects Insta 1, enter weight and press start. Remove, and serve hot.			

CAULIFLOWER KURMA	Insta 1	CAULIFLOWER KURMA			
		Ingredients:			
		cauliflower, cut into florets	2 cup	3 cup	4 cup
		tomatoes, cut into cubes	1 cup	1½ cup	2 cup
		onion	1 cup	1½ cup	2 cup
		yogurt	1 cup	1½ cup	2 cup
		ginger-garlic paste	1 tsp	1½ tsp	2 tsp
		red chili powder	1 tsp	1½ tsp	2 tsp
		khus khus paste	1 tbsp	1½ tbsp	2 tbsp
		cumin seeds	½ tsp	¾ tsp	1 tsp
		turmeric powder	¼ tsp	¼ tsp	½ tsp
		cardamom	few	few	few
		coriander seeds	1 tsp	1½ tsp	2 tsp
		cloves	2	3	4
		curry leaves	few	few	few
		salt to taste			
		oil as required			
		coriander leaves for garnish			
		Method of preparation			
		Prepare tadka in a microwave oven safe bowl as explained in Insta 3 with all the ingredients other than cauliflower, tomato, yogurt and coriander leaves. After beep, remove, add the all ingredients other than coriander leave and mix well. Place the bowl in the microwave oven selects Insta 1, enter weight and press start. Remove, garnish with coriander leaves and serve hot.			

METHI CHUTNEY	Insta 1	METHI CHUTNEY			
		Ingredients:			
		methi leaves	3 cups	4 cup	5 cup
		sesame seeds	¼ cup	½ cup	¾ cup
		urad dal	2 tsp	3 tsp	4 tsp
		dried red chillies	6	8	10
		tamarind juice	¼ cup	½ cup	¾ cup
		salt to taste			
		peanut oil as required			
		Method of preparation			
		Take a microwave oven safe bowl, add all the ingredients and mix well. Place the bowl in the microwave oven selects Insta 1, enter weight and press start. Remove, set to cool and blend the mixture into a smooth paste.			

EGGPLANT TOMATO CURRY	Insta 1	EGGPLANT TOMATO CURRY			
		Ingredients:			
		Masoor Dal	1 cup	1½ cup	2 cup
		Baby Eggplants chopped	1 cup	1½ cup	2 cup
		Tomato chopped	1 cup	1½ cup	2 cup
		Green Chiles chopped	2	3	4
		Broken Dried Red Chiles	2	3	4
		Red Chile Powder	1 tsp	1½ tsp	2 tsp
		Tamarind juice	½ cup	¾ cup	1 cup
		Turmeric Powder	¼ tsp	¼ tsp	½ tsp
		Mustard Seeds	½ tsp	¾ tsp	1 tsp
		Cumin Seeds	½ tsp	¾ tsp	1 tsp
		Garlic paste	½ tsp	¾ tsp	1 tsp
		Curry Leaves	few	few	few
		Oil as required			
		Salt to taste			
		Method of preparation			
		Prepare tadka in a microwave oven safe bowl as explained in Insta 3 with all the ingredients other than eggplants, tomato and tamarind juice. After beep, remove, add the all ingredients and mix well. Place the bowl in the microwave oven selects Insta 1, enter weight and press start. Remove, and serve hot.			

EGG KURMA	Insta 1	EGG KURMA			
		Ingredients:			
		beaten eggs	3	4	5
		grated coconut	½ cup	¾ cup	1 cup
		onion, chopped	½ cup	¾ cup	1 cup
		milk	2 tbsp	2 tbsp	3 tbsp
		cashew nuts	2 tbsp	2 tbsp	3 tbsp
		green chilies, chopped	2	3	4
		coriander powder	1 tsp	1½ tsp	2 tsp
		cloves	2	3	4
		cinnamon	2	3	4
		cardamoms	1 stick	2 stick	3 stick
		ginger paste	½ tsp	¾ tsp	1 tsp
		turmeric powder	¼ tsp	¼ tsp	½ tsp
		ghee as required			
		salt to taste			
		Method of preparation			
		Prepare tadka in a microwave oven safe bowl as explained in Insta 3 with all the ingredients other than egg and milk. After beep, remove, add the all ingredients and mix well. Place the bowl in the microwave oven selects Insta 1, enter weight and press start. Remove, and serve hot.			

CHICKEN CURRY	Insta 1	CHICKEN CURRY			
		Ingredients:			
		chicken	2 cup	3 cup	4 cup
		mushrooms, drained	1 cup	1½ cup	2 cup
		chopped onion	1 cup	1½ cup	2 cup
		garlic, minced	½ tsp	¾ tsp	1 tsp
		cornstarch	½ cup	¾ cup	1 cup
		curry powder	½ tsp	¾ tsp	1 tsp
		chicken stock	½ cup	¾ cup	1 cup
		milk	½ cup	¾ cup	1 cup
		salt to taste			
		butter as required			
		coriander leaves for garnish			
		Method of preparation			
		Prepare tadka in a microwave oven safe bowl as explained in Insta 3 with all the ingredients other than mushroom, corn starch, chicken stock, coriander leaves and milk. After beep, remove, add all the ingredients other than coriander leaves and mix well. Place the tomatoes in the microwave oven select Insta 1, enter weight and press start. Remove, garnish with coriander leaves and serve hot.			

DOI MACHCH	Insta 1	DOI MACHCH					
		Ingredients:					
		Fish (Rohu)-sliced & rubbed with turmeric & salt	230 gms	460 gms	690 gms		
		Curd	1 cup	1½ cup	2 cup		
		Onion paste	1 cup	1½ cup	2 cup		
		Garlic paste	½ tsp	¾ tsp	1 tsp		
		Ginger paste	½ tsp	¾ tsp	1 tsp		
		Turmeric powder	¼ tsp	¼ tsp	½ tsp		
		Chilli powder	1 tsp	1½ tsp	2 tsp		
		Bay leaves	2	2	3		
		Cumin seeds	½ tsp	¾ tsp	1 tsp		
		Cardamoms	3	4	5		
		Cloves	2	3	4		
		Cinnamon-broken	1	2	3		
		Sugar	1 tsp	1½ tsp	2 tsp		
		Oil as required					
		Salt to taste					
		Method of preparation					
		Prepare tadka in a microwave oven safe bowl as explained in Insta 3 with fish. After beep, remove; add all the ingredients mix smoothly. Place the bowl in the microwave oven selects Insta 2, enter weight and press start. Serve hot.					

POMFRET FRY	Insta 1	POMFRET FRY					
		Ingredients:					
		Pomfret - washed and cleaned	230 gms	460 gms	690 gms		
		garlic	½ tsp	½ tsp	1 tsp		
		lemon juice	1 tsp	1½ tsp	2 tsp		
		chilli powder	1 tsp	1½ tsp	2 tsp		
		turmeric powder	¼ tsp	¼ tsp	½ tsp		
		pepper powder	1 tsp	1½ tsp	2 tsp		
		garam masala	1 tsp	1½ tsp	2 tsp		
		rice flour	½ tbsp	1tbsp	1 tbsp		
		oil as required					
		salt to taste					
		Method of preparation					
		Mix all the ingredients other than Pomfret to make a paste. Toss the fish into it and apply evenly on all sides. Set aside for 1 hr. Arrange the marinated fish in a flat base glass bowl. Place the bowl in the microwave oven, select Insta 1, enter weight and press start. Remove and serve.					

PRAWNS CURRY	Insta 1	PRAWNS CURRY			
		Ingredients:			
		prawn - shelled	230 gms	460 gms	690 gms
		onions cut into small pieces	1	2	3
		garlic paste	½ tsp	½ tsp	1 tsp
		ginger paste	½ tsp	½ tsp	1 tsp
		chilli powder	1 tsp	1½ tsp	2 tsp
		turmeric powder	¼ tsp	¼ tsp	½ tsp
		mustard seeds	½ tsp	½ tsp	1 tsp
		oil as required			
		salt to taste			
		Method of preparation			
Prepare tadka in a microwave oven safe glass bowl as explained in Insta 3 with all the ingredients other than the prawns. Remove, add the prawns and mix well. Place the bowl in the microwave oven, select Insta 1, enter weight and press start. Remove and serve.					

DUM ALOO	Insta 1	DUM ALOO			
		Ingredients:			
		aloo (potatoes)	230 gms	460 gms	690 gms
		tomato puree	1 cup	1½ cup	2 cup
		curd	½ cup	1 cup	1½ cup
		ghee as required			
		Spices			
		cloves	2	3	4
		bay leaves	1	2	3
		black peppercorns	4	5	6
		green cardamoms	2	3	4
		brown cardamom	2	3	4
		cinnamon stick	1	2	3
		Paste			
		onion (chopped)	1	2	3
		flakes garlic	3	4	6
		ginger	¼" inch	½" inch	½" inch
		black peppercorns	4	5	6
		poppy seeds	½ tsp	½ tsp	1 tsp
		coriander seeds	½ tsp	½ tsp	1 tsp
		cumin seeds	½ tsp	½ tsp	1 tsp
		dry red chilies	2	3	4
		turmeric powder	¼ tsp	¼ tsp	½ tsp
		ground mace	a pinch	a pinch	a pinch
		ground nutmeg	a pinch	a pinch	a pinch
		salt to taste			
Method of preparation					
Prepare tadka in a microwave oven safe bowl as explained in Insta 3 with all the ingredients other than palak and paneer. After beep, remove, add all the ingredients and mix well. Place the bowl in the microwave oven selects Insta 1, enter weight and press start. Serve hot.					

COFFEE	Insta 2	COFFEE			
			200ml	400ml	600ml
		Ingredients;			
		Coffee powder	1½ tsp	2 tsp	3 tsp
		Milk	2 cups	3 cups	4 cups
		Sugar to taste			
		Water as required			
		Method of preparation:			
		Take a microwave oven safe large bowl, add water, milk, sugar, coffee powder, mix well. Select Insta 2, enter weight, press start.			

PEDA	Insta 2	PEDA	200gm	400gm	600gm
		Ingredients;			
		Soft Khoya	200gm	400gm	600gm
		Sugar Powdered	1 cup	1½ cup	2 cups
		Cardamom Powder	¼ tsp	¼ tsp	½ tsp
		Cardamom Seeds (Crushed)	¼ tsp	¼ tsp	½ tsp
		Pistachios	few	few	Few
		Method of preparation:			
		Take a microwave oven safe glass bowl, add all ingredients other than cardamom seeds and pistachios, mix well and select Insta 2, enter weight, press start After beep, remove and set to cool. When set well, make peda shape and garnish with cardamom seeds and pistachios on top and serve.			

VEGETABLE STOCK	Insta 2	VEGETABLE STOCK	200ml	400ml	600ml
		Ingredients;			
		Onion Chopped	½ cup	1 cup	1½ cup
		Carrots Chopped	1 cup	1 cup	2 cups
		Celery Chopped	1 stalks	2 stalks	3 stalks
		Coriander	2 stems	4 stems	6 stems
		Peppercorns	1 tsp	1 tsp	2 tsp
		Water As Required			
		Method of preparation:			
		Add all the ingredients in a microwave oven safe bowl other than water and mix well. Place the bowl in the microwave oven and select Insta 3 Tadka option. Set weight, press start. After beep, remove and add water, mix well and select Insta 2, set weight, press start. Set to cool then strain them and use whenever required.			

GARAM MASALA	Insta 2	GARAM MASALA	200gm	400gm	600gm
		Ingredients;			
		Dried Ginger Powder	1 tsp	1½ tsp	2 tsp
		Cardamom Seeds	½ tbsp	¾ tbsp	1 tbsp
		Cumin Seeds	½ tbsp	¾ tbsp	1 tbsp
		Black Cumin (Shahjeera)	½ tbsp	¾ tbsp	1 tbsp
		Dried Coriander Seeds	½ tbsp	¾ tbsp	1 tbsp
		½" Cinnamon Sticks	3	5	6
		Black Peppercorns	½ tsp	½ tsp	1 tsp
		Cloves	3	4	5
		Star Anise	1	2	2
		Nutmeg	½	¾	1
		Mace Powder (Javantari)	½ tsp	½ tsp	½ tsp
		Bay Leaf	2 long	3 long	4 long
		Method of preparation:			
		Take a microwave oven safe glass bowl, add all ingredients, mix well and place the bowl in the microwave oven. Select Insta 2, enter weight and press start.			

CHANA CHAT	Insta 2	CHANA CHAT	200gm	400gm	600gm
		Ingredients;			
		chana	100 gms	200 gms	300 gms
		tomato chopped to small pieces	50 gms	100 gms	150 gms
		cucumber cut to small pieces	50 gms	100 gms	150 gms
		chat masala	1 tsp	1½ tsp	2 tsp
		red chilly powder	1 tsp	1½ tsp	2 tsp
		cumins powder	1 tsp	1½ tsp	2 tsp
		lime juice	½ tsp	½ tsp	1 tsp
		chopped coriander	few	few	few
		salt to taste			
		Method of preparation:			
		Take a microwave oven safe bowl, add channa and tomato, place the bowl in the microwave oven. Select Insta 2, enter weight and press start. After beep, add all remaining ingredients mix well and serve.			

TADKA/ TALIMPU/ VAGAR/ HOGARNE/ PHODNI/ CHOWK	Insta 3	TADKA/ TALIMPU/ VAGAR/ HOGARNE/ PHODNI/ CHOWK	
		Ingredients:	
		oil / ghee as required	
		Green chillies	2
		chopped onions	2
		jeera	¾ tsp
		garlic	¾ tsp
		ginger	¾ tsp
		hing	a pinch
		Mustard seeds	¼ tsp
		turmeric powder	¼ tsp
		red chili powder	1 tsp
		curry leaves	few
		cinnamon	2
		cardamom	3
		bay leaves	few
		coriander	few
		cloves	3
		pepper corns	few
		Method of preparation	
		Take a microwave oven safe bowl, add any ingredients according to the recipe, mix well select insta cook 3, enter weight, press start.	

POP CORN	Insta 3	POP CORN	
		Ingredients:	
		pop corn	99 gms
		butter	2 tsp
		red chilli powder (optional)	½ tsp
		turmeric powder	½ tsp
		salt to taste	
		Method of preparation	
		Take a microwave oven safe large glass bowl, add all ingredients, mix well and place the bowl in the microwave oven,select Insta 3, set weight, press start.remove and serve hot.	

BREAD CHIWDA	Insta 3	BREAD CHIWDA	99 gms
		Ingredients:	
		bread slices	few
		mustard seeds	¼ tsp
		cumin seeds	1 tsp
		onion finely chopped	1
		turmeric powder	¼ tsp
		hing	a pinch
		curry leaves	few
		raw peanuts	½ tbsp
		oil as required	
		salt to taste	
		coriander leaves for garnish	
		Method of preparation;	
Prepare tadka in a microwave oven safe bowl as explained in Insta 3 with all the ingredients other than bread slices, hing and coriander leaves. after beep, remove, add the remaining ingredients other than the coriander leaves and mix well. Place the bowl in the microwave oven select Insta 3, enter weight and press start. Remove, garnish with grated coriander and serve.			

MUMPALLY ROAST	Insta 3	MUMPHALI ROAST	
		Ingredients:	
		mumpalli (raw peanuts)	99 gms
		Method of preparation;	
Take a microwave oven safe glass bowl, add mumpally. Place the bowl in the microwave oven select Insta 3, enter weight and press start. For better result stir once in between.			

MIRCHI KA SALAN	Insta 3	MIRCHI KA SALAN	
		Ingredients:	
		Deep fried Green chillies	99 gms
		Onion paste	½ cup
		Ginger garlic paste	½ tsp
		Mustard seeds	½ tsp
		Cloves	few
		Curry leaves	few
		Tamarind pulp	½ cup
		Oil as required	
		Coriander leaves for garnish	
		Salt	
		Salan Paste	
		Grated Coconut	
		Roasted Peanuts	
		Coriander seeds	
		Sesame seeds	
		Cumin seeds	
		Peppercorns	
		Red Chillies	
		Method of preparation;	
		Grind all salan paste ingredients to make fine paste. Prepare tadka in a microwave oven safe bowl as explained in Insta 3 with all the ingredients other than green chillies, tamarind pulp and coriander leaves. after beep, remove, add the remaining ingredients other than the coriander leaves and mix smoothly. Place the bowl in the microwave oven select Insta 3, enter weight and press start. Remove, garnish with grated coriander and serve.	

MURMURA	Insta 3	MURMURA	
		Ingredients:	
		murmura (puffed rice)	99 gms
		peanuts	few
		almonds	few
		cashew nuts	few
		black raisins	few
		coconut flakes	few
		chopped green chilies	2
		curry leaves	few
		mustard seeds	½ tsp
		turmeric powder	¼ tsp
		sugar	½ tsp
		oil as required	
		salt to taste	
		Method of preparation;	
		Prepare tadka in a microwave oven safe bowl as explained in Insta 3 with all the ingredients other than murmura, almonds, cashew and raisins. Remove, add the remaining ingredients and mix well. Place the bowl in the microwave oven select Insta 3, enter weight and press start.	

MASHED POTATO SALAD	Insta 3	MASHED POTATO SALAD	
		Ingredients:	
		mashed potatoes	99 gms
		chopped celery	few
		onion paste	½ cup
		milk	½ cup
		dry mustard	¼ tsp
		green bell pepper rings	few
		pepper to taste	
		salad dressing as required	
		salt to taste	
		Method of preparation;	
		Take a microwave oven safe bowl, add potatoes. Place the bowl in the microwave oven select Insta 3, enter weight and press start. After beep, remove and mash the potatoes with milk and onion. Prepare tadka as explained in Insta 3 with mashed potato and all the ingredients. Remove, warm and serve.	

PAKODA CURRY	Insta 3	PAKODA CURRY	
		Ingredients:	
		pakodas	99 gms
		tomato puree	1 cup
		green chili	2
		ginger paste	½ tsp
		curry leaves	few
		mustard seeds	½ tsp
		cumin seeds	½ tsp
		hing	a pinch
		coriander powder	½ tsp
		red chili powder	½ tsp
		sugar	1 tsp
		turmeric	a pinch
		salt to taste	
		coriander leaves for garnish	
		Method of preparation;	
		Prepare tadka in a microwave oven safe bowl as explained in Insta 3 with all the ingredients other than pakodas, tomato puree and coriander leaves. After beep, remove, add the remaining ingredients other than the coriander leaves and mix well. Place the bowl in the microwave oven select Insta 3, enter weight and press start. Remove, garnish with grated coriander and serve.	

PEANUTS CHUTNEY	Insta 3	PEANUTS CHUTNEY	
		Ingredients:	
		peanuts	99 gms
		red chillies	2
		onion	1 cup
		garlic	½ tsp
		tamarind pulp	½ cup
		cumin	½ tsp
		curry leave	few
		mustard seeds	½ tsp
		urad dal	1 tsp
		salt to taste	
		Method of preparation;	
		Take a microwave oven safe glass bowl, add peanuts and place the bowl in the microwave oven select Insta 3, enter weight and press start. After beep, remove the peanuts and rub the skins off and make a fine paste of the peanuts. Prepare tadka as explained in Insta 3 with peanuts paste and all the ingredients. Remove the chutney and serve.	

MUSHROOM CHILLI FRY	Insta 3	MUSHROOM CHILLI FRY	
		Ingredients:	
		mushrooms cut into halves	99 gms
		mustard seeds	½ tsp
		red chillies	2
		butter to taste	
		salt to taste	
		Method of preparation;	
		Prepare tadka in a microwave oven safe bowl as explained in Insta 3 with all the ingredients other than salt. After beep, remove, add the remaining ingredients and mix well. Place the bowl in the microwave oven select Insta 3, enter weight and press start.	

GREEN CHANA CURRY	Insta 3	GREEN CHANA CURRY	
		Ingredients:	
		green chana	99 gms
		tomato chopped	1 cup
		onion chopped	½ cup
		green chilli chopped	2
		ginger, garlic paste	1 tsp
		cumins powder	½ tsp
		hing	a pinch
		turmeric powder	a pinch
		coriander powder	½ tsp
		garam masala	1 tsp
		oil as required	
		salt to taste	
Method of preparation;			
Prepare tadka in a microwave oven safe bowl as explained in Insta 3 with all the ingredients other than green chana and tomato. After beep, remove, add the remaining ingredients and mix well. Place the bowl in the microwave oven select Insta 3, enter weight and press start.			

STIR FRIED OATS	Insta 3	STIR FRIED OATS	
		Ingredients:	
		oats	99 gms
		raisins	few
		flour	½ tbsp
		cinnamon	1 stick
		sugar	1 tsp
		butter as required	
		salt to taste	
		Method of preparation;	
Prepare tadka in a microwave oven safe bowl as explained in Insta 3 with all the ingredients other than raisins and flour. After beep, remove, add the remaining ingredients and mix well. Place the bowl in the microwave oven select Insta 3, enter weight and press start.			

BESAN KA LADOO	Insta 3	BESAN KA LADOO	99 gms
		Ingredients:	
		besan	1½ cups
		sugar (grinded)	1 cup
		ghee	¾ cup
		almonds (roasted)	few
		pistachios	few
		cashew nuts (roasted)	few
		Method of preparation;	
		Take a microwave oven safe glass bowl, add ghee and besan, mix well and place the bowl in the microwave oven select Insta 3, enter weight and press start.(stir twice in between to avoid lumps).After beep, remove and add all the ingredients to the flour, mix thoroughly and form small balls like ladoo.	

SEV- BHAJI	Insta 3	SEV- BHAJI	
		Ingredients:	
		sev	99 gms
		tomato puree	1 tbsp
		chopped onions	1
		mustard seeds	¼ tsp
		cumin seeds	¼ tsp
		green chilli	1
		hing	a pinch
		curry leaves	few
		turmeric powder	¼ tsp
		red chilli powder	1tsp
		ground coriander	½ tsp
		ground cumin	½ tsp
		oil as required	
		salt to taste	
		coriander leaves for garnish	
		Method of preparation;	
		Prepare tadka in a microwave oven safe bowl as explained in Insta 3 with all the ingredients other than sev, tomato puree and coriander leaves. After beep, remove, add the remaining ingredients other than the coriander leaves and mix well. Place the bowl in the microwave oven select Insta 3, enter weight and press start.Remove, garnish with grated coriander and serve.	

DALIYA KICHDI	Insta 3	DALIYA KICHDI	
		Ingredients:	
		dalia (broken wheat)	99 gms
		mix vegetable chopped	1 cup
		onion chopped	1
		green chilies	2
		garlic, ginger paste	1 tsp
		turmeric powder	a pinch
		cumins seeds	1 tsp
		coriander powder	1 tsp
		oil as required	
		salt to taste	
		coriander leaves for garnish	
		Method of preparation;	
		Prepare tadka in a microwave oven safe bowl as explained in Insta 3 with all the ingredients other than dalia and coriander leaves. After beep, remove, add the remaining ingredients other than the coriander leaves and mix well. Place the bowl in the microwave oven select Insta 3, enter weight and press start. Remove, garnish with grated coriander and serve.	

PANEER PEAS CURRY	Insta 3	PANEER PEAS CURRY	
		Ingredients:	
		paneer cubed	99 grm
		green peas	1 cup
		onions	1
		tomato puree	1 cup
		ginger, garlic paste	½ tsp
		coriander powder	½ tsp
		cumin powder	½ tsp
		garam masala	½ tsp
		turmeric powder	¼ tsp
		green chillies chopped	2
		heavy cream	¼ cup
		oil as required	
		salt to taste	
		coriander leaves for garnish	
		Method of preparation;	
		Prepare tadka in a microwave oven safe bowl as explained in Insta 3 with all the ingredients other than paneer, tomato puree, heavy cream and coriander leaves. After beep, remove, add the remaining ingredients other than the coriander leaves and mix well. Place the bowl in the microwave oven select Insta 3, enter weight and press start. Remove, garnish with grated coriander and serve.	

TOMATO SOUP	Insta 4	TOMATO SOUP							
		Ingredients:							
		tomatoes - large	200 gms	300 gms	400 gms	500 gms	600 gms	700 gms	800 gms
		Mint leaves	few	few	few	few	few	few	few
		pepper to taste							
		salt to taste							
		Method of preparation:							
		Take a microwave oven safe bowl; add salt, pepper, tomatoes, mix well and select Insta 3, enter weight & press start. Remove after beep, add mint leaves, mix well and select Insta 4, set weight, press start. when cool, blend the tomatoes in a mixer. strain and serve hot.							

VEGETABLE CHAT	Insta 4	VEGETABLE CHAT							
		Ingredients:							
		sev	40 gms	60 gms	80 gms	100 gms	120 gms	140 gms	160 gms
		peanuts - roasted & crushed	40 gms	60 gms	80 gms	100 gms	120 gms	140 gms	160 gms
		boiled potato - diced into small cubes	40 gms	60 gms	80 gms	100 gms	120 gms	140 gms	160 gms
		chick peas (kabuli channa) - Boiled (optional)	40 gms	60 gms	80 gms	100 gms	120 gms	140 gms	160 gms
		corn kernel - Boiled	40 gms	60 gms	80 gms	100 gms	120 gms	140 gms	160 gms
		onion - chopped finely	½	½	½	½	1	1	1
		green chilli - chopped finely	1	1	2	2	2	3	3
		tomato - chopped finely	½	½	½	½	1	1	1
		fresh coriander leaves - chopped	½ tbsp	½ tbsp	½ tbsp	½ tbsp	1 tbsp	1 tbsp	1 tbsp
		chaat masala powder (optional)	1 tsp	1 tsp	1 tsp	1½ tsp	1½ tsp	1½ tsp	1½ tsp
		red chilli powder	½ tsp	½ tsp	½ tsp	1 tsp	1 tsp	1 tsp	1 tsp
		lemon juice	½ tsp	½ tsp	½ tsp	1 tsp	1 tsp	1 tsp	1 tsp
		tamarind chutney	½ tbsp	½ tbsp	½ tbsp	1 tbsp	1 tbsp	1 tbsp	1 tbsp
		salt to taste							
		Method of preparation:							
		Take a Microwave oven safe bowl, combine all the ingredients, mix well, keep bowl on the turn table and select Insta 4, enter weight, press start. Remove and serve.							

OMLETTE	Insta 4	OMLETTE							
		Ingredients:							
		eggs - beaten	2	3	4	5	6	7	8
		onion - finely chopped	1	1	2	2	3	3	3
		green chillies - finely chopped	1	2	2	3	3	4	4
		red chilli powder	½ tsp	½ tsp	1 tsp	1 tsp	1½ tsp	1½ tsp	2 tsp
		oil as required							
		coriander leaves for garnish							
		salt To Taste							
		Method of preparation;							
		Prepare tadka in a microwave oven safe flat bowl as explained in Insta 3 with all the ingredients other than egg and coriander leaves. Remove, add the beaten eggs, but not the coriander leaves and mix well. Place the bowl in the microwave oven, select Insta 4, enter weight and press start. Remove, garnish with coriander leaves and serve							

SABUDANA KICHDI	Insta 4	SABUDANA KICHDI							
		Ingredients:							
		sabudana (soaked)	100 gms	150 gms	200 gms	250 gms	300 gms	350 gms	400 gms
		ground nut powder	100 gms	150 gms	200 gms	250 gms	300 gms	350 gms	400 gms
		chopped green chillies	2	2	3	3	4	4	5
		boiled & peeled potato	½ cup	1 cup	1 cup	1½ cup	1½ cup	2 cup	2 cup
		oil	½ tbsp	½ tbsp	¾ tbsp	¾ tbsp	1tbsp	1tbsp	1tbsp
		hing	a pinch	a pinch	a pinch	a pinch	a pinch	a pinch	a pinch
		cumin seeds	½ tsp	¾ tsp	1 tsp	1 tsp	1½ tsp	2 tsp	2 tsp
		sugar	1 tsp	1½ tsp	2 tsp	2 tsp	2½ tsp	2½ tsp	3 tsp
		lime juice	½ tsp	¾ tsp	1 tsp	1 tsp	1½ tsp	2 tsp	2 tsp
		salt to taste							
		Method of preparation:							
		Prepare tadka as explained in Insta 3 in a microwave oven safe glass bowl with all the ingredients other than sabudana, salt, sugar and lime. Remove; add the remaining ingredients and mix well. Cover the bowl with lid and place it in the microwave oven. Select Insta 4, enter weight and press start. Remove and mix well and serve hot.							

TOMATO PUREE	Insta 4	TOMATO PUREE							
		Ingredients;							
		tomatoes	200 gms	300 gr	400 gr	500 gms	600 gms	700 gms	800 gms
		Method of preparation:							
		Take a microwave oven safe bowl, add tomatoes, and place the bowl in the microwave oven.select Insta 4, set weight and press start. Set a side to cool, remove the top cover, smatch and serve.							

TAMARIND PULP	Insta 4	TAMARIND PULP							
		Ingredients:							
		tamarind	200 gms	300 gms	400 gms	500 gms	600 gms	700 gms	800 gms
		water as required							
		Method of preparation:							
		Take a microwave oven safe bowl, add tamarind and water, keep aside for some time.Place the bowl on the turn table in the microwave oven, select insta 4, enter weight & press start.Remove, and smatch the tamarind smoothly to make pulp.							

CORN CHAT	Insta 4	CORN CHAT							
		Ingredients:	200 gms	300 gms	400 gms	500 gms	600 gms	700 gms	800 gms
		sweet corn kernels	¼ cup	½ cup	¾ cup	1 cup	1¼ cup	1½ cup	1¾ cup
		tomato chopped to small pieces	¼ cup	½ cup	¾ cup	1 cup	1¼ cup	1½ cup	1¾ cup
		cooked potato cut into small pieces	¼ cup	½ cup	¾ cup	1 cup	1¼ cup	1½ cup	1¾ cup
		cucumber cut into small pieces	¼ cup	½ cup	¾ cup	1 cup	1¼ cup	1½ cup	1¾ cup
		chopped coriander	½ tbsp	½ tbsp	½ tbsp	1 tbsp	1 tbsp	1 tbsp	1½ tbsp
		lime juice	¼ tsp	¼ tsp	½ tsp	¾ tsp	¾ tsp	1 tsp	1 tsp
		chat masala	1 tsp	1 tsp	1½ tsp	2 tsp	2 tsp	2½ tsp	2½ tsp
		cumins powder	1 tsp	1 tsp	1 tsp	1½ tsp	1½ tsp	2 tsp	2 tsp
		red chilli powder	1 tsp	1 tsp	1 tsp	1 tsp	1½ tsp	2 tsp	2 tsp
		salt to taste							
		Method of preparation							
Take a microwave oven safe bowl, add sweet corn, tomatoes, chat masala, cumins powder, red chilli powder, salt, mix well and select Insta 4, enter weight and press start. Remove and serve hot.									

FENNEL (saunf) ROAST	Insta 4	FENNEL (saunf) ROAST							
		Ingredients:							
		fennel seeds	200 gms	300 gms	400 gms	500 gms	600 gms	700 gms	800 gms
		Method of preparation							
Take a microwave oven safe glass bowl, add fennel, place the bowl in microwave oven and select Insta 4, enter weight and press start.									

CASHEW ROAST	Insta 4	CASHEW ROAST							
		Ingredients:							
		cashew nuts	200 gms	300 gms	400 gms	500 gms	600 gms	700 gms	800 gms
		Method of preparation							
Take a microwave oven safe bowl, add cashew nuts, place the bowl in microwave oven and select Insta 4, enter weight and press start.									

RICE REHEAT	Insta 4	RICE REHEAT							
		Ingredients:							
		cooked rice	200 gms	300 gms	400 gms	500 gms	600 gms	700 gms	800 gms
		Method of preparation							
		Take a microwave oven safe bowl, add cooked rice, place the bowl in microwave oven and select Insta 4, enter weight and press start.							

ROTI CHI-WDA	Insta 4	ROTI CHIWDA							
		Ingredients:	200 gms	300 gms	400 gms	500 gms	600 gms	700 gms	800 gms
		left over roti (break into small pieces)	1 cup	1½ cup	2 cup	2½ cup	3 cup	3½ cup	4 cup
		onions finely chopped	1	1	1½	1½	2	2	2½
		green chilies finely chopped	2	2	2	3	3	3	4
		cumin seeds	½ tsp	½ tsp	1 tsp	1 tsp	1½ tsp	1½ tsp	1½ tsp
		mustard seeds	½ tsp	½ tsp	1 tsp	1 tsp	1½ tsp	1½ tsp	1½ tsp
		turmeric powder	¼ tsp	¼ tsp	¼ tsp	½ tsp	½ tsp	½ tsp	½ tsp
		curry leaves	few	few	few	few	few	few	few
		roasted ground nuts	few	few	few	few	few	few	few
		lemon juice	½ tsp	½ tsp	1 tsp				
		chopped coriander leaves							
		oil as required							
		salt to taste							
		Method of preparation							
		Prepare tadka in a microwave oven safe flat bowl as explained in Insta 3 with all the ingredients other than roti, lime juice and coriander leaves. After beep, remove and add all the ingredients other than coriander leaves and lime juice, mix well. Place the bowl in the microwave oven, select Insta 4, enter weight and press start. Remove, pour lime juice and garnish with coriander leaves.							

Spaghetti	Insta 5	Spaghetti	100 g	200g	300g
		Ingredients;			
		spaghetti	1 cup	1½ cup	1½ cup
		carrot - chopped	¼ cup	½ cup	½ cup
		butter	½ tbsp	½ tbsp	1 tbsp
		capsicum - chopped	¼ cup	½ cup	½ cup
		mushrooms - chopped	¼ cup	½ cup	½ cup
		tomatoes - chopped	¼ cup	½ cup	½ cup
		oregano	a pinch	a pinch	a pinch
		basil	a pinch	a pinch	a pinch
		green peas	¼ cup	½ cup	½ cup
		green onion - chopped	½ tbsp	½ tbsp	1 tbsp
		tomato ketchup (optional)	½ tbsp	½ tbsp	1 tbsp
		grated cheese for garnish			
		salt to taste			
		Method of preparation;			
		Prepare tadka in a microwave oven safe glass bowl as explained in Insta 3 with all the ingredients other than tomatoes, spaghetti, green peas and tomato ketchup; mix well. Remove, add the remaining ingredients other than grated cheese and mix well. Place the bowl in the microwave oven, select Insta 5, enter weight and press start. Remove, garnish and serve.			

CURD RICE	Insta 5	CURD RICE	100 g	200g	300g
		Ingredients;			
		rice	2 cups	3 cups	4 cups
		dahi / yogurt	200 gms	300 gms	400 gms
		milk	1 cup	1½ cup	1½ cup
		musturd seeds	½ tsp	½ tsp	1 tsp
		cumins seeds	½ tsp	½ tsp	1 tsp
		dry red chilly (cut into small)	2	3	4
		ghee	1 tbsp	1 tbsp	1½ tbsp
		medium size cucumber grated	½	¾	1
		seedless grapes (chopped)	50 gms	75 gms	100 gms
		promegranate (dalim) seeds	¼ cut	½ cut	¾ cut
		water as required			
		salt to taste			
		Method of preparation			
		Prepare tadka in a microwave oven safe bowl as explained in Insta 3 with all the ingredients other than rice, yogurt, milk, cucumber, grapes, dalim and water. Remove, add the remaining ingredients other than grapes, and dalim, mix well. Place the bowl in the microwave oven, select Insta 5, enter weight and press start. Remove, add grapes, dalim and serve hot.			

VEGETABLE BIRYANI	Insta 5	VEGETABLE BIRYANI	100 g	200g	300g
		Ingredients:			
		rice	1½ cup	2 cup	3 cup
		ghee	1tbsp	1tbsp	1½ tbsp
		carrot chopped	¼ cup	½ cup	¾ cup
		french beans chopped	¼ cup	½ cup	¾ cup
		green peas	¼ cup	½ cup	¾ cup
		red chilli powder	½ tsp	¾ tsp	1 tsp
		garam masala	¾ tsp	1 tsp	1½ tsp
		garlic paste	¼ tsp	¼ tsp	½ tsp
		ginger paste	¼ tsp	¼ tsp	½ tsp
		green chillies chopped	¼ tbsp	¼ tbsp	½ tbsp
		onion chopped	1	1½	1½
		tomato chopped	1	1½	2
		cinnamon	½ inch	¾ inch	1 inch
		cloves	4	5	6
		cardamom	4	5	6
		coconut milk	1cup	1½ cup	2 cup
		cashew nuts	few	few	few
		mint leaves	few	few	few
		coriander leaves	few	few	few
		lemon juice	½ tsp	¾ tsp	1 tsp
		salt to taste			
		water as required			
		Method of preparation			
		Prepare tadka in a microwave oven safe bowl as explained in Insta 3 with all the ingredients other than rice, tomato, coconut milk, water, mint leaves, coriander leaves, lemon juice and salt. Remove, add the remaining ingredients and mix well. Place the bowl in the microwave oven, select Insta 5, enter weight and press start. Remove, and serve hot.			

RICE KICHDI	Insta 5	RICE KICHDI	100 g	200g	300g
		Ingredients:			
		rice	1½ cup	2 cup	3 cup
		toor dal	½ cup	¾ cup	1 cup
		garlic paste	½ tsp	¾ tsp	1 tsp
		ginger paste	½ tsp	¾ tsp	1 tsp
		turmeric powder	¼ tsp	½ tsp	¾ tsp
		oil	1 tbsp	1 tbsp	1½ tbsp
		cardamom	½ inch	¾ inch	1 inch
		cinnamon	3	4	5
		cloves	3	4	5
		sliced onion	1	2	2
		chopped tomatoes	2	3	3
		slitted green chillies	2	3	4
		mint leaves	few	few	few
		curry leaves	few	few	few
		salt to taste			
		water as required			
		coriander leaves for garnish			
Method of preparation					
Prepare tadka in a microwave oven safe bowl as explained in Insta 3 with all the ingredients other than rice, toor dal, water, tomatoes and coriander leaves. Remove, add the remaining ingredients and mix well. Place the bowl in the microwave oven, select Insta 5, enter weight and press start. Remove, and serve hot.					

DALCHA	Insta 5	DALCHA	100 g	200g	300g
		Ingredients:			
		soaked channa dal	100 gms	200 gms	300 gms
		lauki (cut into pieces)	1½ cup	2 cup	3 cup
		oil	1 tbsp	1 tbsp	1½ tbsp
		onion paste	1 cup	1 cup	1½ cup
		curry leaves	few	few	few
		red chillipowder	1 tsp	1½ tsp	2 tsp
		turmeric powder	¼ tsp	½ tsp	¾ tsp
		ginger paste	½ tsp	¾ tsp	1 tsp
		garlic paste	½ tsp	¾ tsp	1 tsp
		cumin seeds	1 tsp	1½ tsp	2 tsp
		tamarind juice	½ cup	¾ cup	1 cup
		salt to taste			
		water as required			
Method of preparation					
Prepare tadka in a microwave oven safe bowl as explained in Insta 3, with all the ingredients other than channa dal, lauki, tamarind juice and water. Remove, add the remaining ingredients except coriander leaves and mix well. Place the bowl in the microwave oven, select Insta 5, enter weight and press start. Remove, garnish with coriander and serve hot.					

JEERA RICE	Insta 5	JEERA RICE	100 g	200g	300g
		Ingredients:			
		rice	1½ cup	2 cup	3 cup
		jeera (cumin seeds)	2 tsp	2 tsp	3 tsp
		cashew nuts	2 tbsp	2 tbsp	3 tbsp
		peppercorns	4	5	6
		bay leafs	2	3	4
		cloves	3	4	4
		cinnamon sticks	2	3	4
		onions, sliced	1	2	2
		ghee as required			
		salt To Taste			
		water as required			
Method of preparation					
Prepare tadka in a microwave oven safe bowl as explained in Insta 3 with all the ingredients other than rice and water. Remove, add the remaining ingredients and mix well. Place the bowl in the microwave oven, select Insta 5, enter weight and press start. Remove, and serve hot.					

EGGPLANT DAL	Insta 5	EGGPLANT DAL	100 g	200g	300g
		Ingredients:			
		toovar dal	1½ cup	2 cup	3 cup
		eggplants chopped	2 cup	3 cup	4 cup
		dried coconut	1tbsp	1tbsp	1½ tbsp
		turmeric powder	¼ tsp	¼ tsp	½ tsp
		green chillies	3	4	5
		cumins seeds	½ tsp	¾ tsp	1 tsp
		garlic, ginger paste	1 tsp	1½ tsp	2 tsp
		musturd seeds	½ tsp	¾ tsp	1 tsp
		oil as required			
		salt to taste			
Method of preparation					
Prepare tadka in a microwave oven safe bowl as explained in Insta 3 with all the ingredients other than dal and egg plants. Remove. add the remaining ingredients and mix well. Place the bowl in the microwave oven, select Insta 5, enter weight and press start. Remove, and serve hot.					

AMRITSARI DAL	Insta 5	AMRITSARI DAL	100 g	200g	300g
		Ingredients:			
		urad dal	1 cup	2 cup	3 cup
		channa dal	1 cup	2 cup	3 cup
		tomatoes	2	3	3
		onion chopped	1	2	2
		mint leaves	few	few	few
		ginger, garlic paste	1 tsp	1½ tsp	2 tsp
		green chillies chopped	2	2	3
		butter as required			
		salt to taste			
		Method of preparation			
		Prepare tadka in a microwave oven safe bowl as explained in Insta 3 with all the ingredients other than dal and egg plants. Remove. add the remaining ingredients and mix well. Place the bowl in the microwave oven, select Insta 5, enter weight and press start. Remove, and serve hot.			

DAL MAKHANI	Insta 5	DAL MAKHANI	100 g	200g	300g
		Ingredients:			
		urad daal	1 cup	1½ cup	2 cup
		tomato finely chopped	2	3	4
		onion finely chopped	1	1	2
		ginger, garlic paste	1 tsp	1½ tsp	2 tsp
		chilies finely chopped	few	few	few
		curd	1 cup	1½ cup	2 cup
		cream (malai)	½ cup	¾ cup	1 cup
		cumin seeds	½ tsp	¾ tsp	1 tsp
		turmeric powder	¼ tsp	¼ tsp	½ tsp
		garam masala	1 tsp	1½ tsp	2 tsp
		red chili powder	1 tsp	1½ tsp	2 tsp
		dhania powder	1 tsp	1½ tsp	2 tsp
		butter as required			
		chopped coriander leaves for garnish			
		salt to taste			
		Method of preparation			
		Prepare tadka in a microwave oven safe bowl as explained in Insta 3 with all the ingredients other than urad dal, tomato, cream, curd and coriander. Remove. add the remaining ingredients other than coriander and mix well. Place the bowl in the microwave oven, select Insta 5, enter weight and press start. Remove, and garnish with coriander leaves. serve hot.			

RASAM	Insta 5	RASAM	100 g	200g	300g
		Ingredients:			
		red gram dal	1½ cup	2 cup	3 cup
		tomatoes	1	2	3
		ginger paste	½ tsp	¾ tsp	1 tsp
		garlic paste	½ tsp	¾ tsp	1 tsp
		green chillies chopped	1	2	2
		turmeric powder	¼ tsp	¼ tsp	½ tsp
		mustard seeds	½ tsp	¾ tsp	1 tsp
		cumin seeds	½ tsp	¾ tsp	1 tsp
		dried red chillies	2	3	3
		hing	a pinch	a pinch	a pinch
		curry leaves	few	few	few
		pepper powder	½ tsp	¾ tsp	1 tsp
		oil as required	1 tbsp	1 tbsp	1½ tbsp
		salt to taste			
		coriander leaves for garnish			
		Method of preparation			
		Prepare tadka in a microwave oven safe bowl as explained in Insta 3 with all the ingredients other than tomato, hing and coriander. Remove. add the remaining ingredients other than coriander and mix well. Place the bowl in the microwave oven, select Insta 5, enter weight and press start. Remove, and garnish with coriander leaves. serve hot.			

SAMBAR	Insta 5	SAMBAR	100 g	200g	300g
		Ingredients:			
		red gram dal	1 cup	1½ cup	2 cup
		turmeric powder	¼ tsp	¼ tsp	½ tsp
		bitter gourd (sliced into long pieces)	50 gms	100 gms	150 gms
		brinjal (sliced into long pieces)	2	3	4
		drum stick (sliced into long pieces)	½ stick	¾ stick	1 stick
		ladies finger (sliced into long pieces)	3	4	5
		dried red chillies	4	4	5
		curry leaves	1 spring	1 spring	2 spring
		tamarind	20 gms	30 gms	40 gms
		hing	¼ tsp	½ tsp	½ tsp
		red chilli powder	1 tsp	1½ tsp	2 tsp
		oil	½ tbsp	¾ tbsp	1 tbsp
		white gram dal (fried)	1 tsp	1½ tsp	2 tsp
		coriander seeds (fried)	½ tsp	¾ tsp	1 tsp
		musturd seeds (fried)	½ tsp	¾ tsp	1 tsp
		coriander leaves for garnish			
		musturd seeds for tadka			
		water as required			
		salt to taste			
		Method of preparation			
		Make a paste of fried white gram dal, coriander seeds, musturd seeds, keep aside. Mash the tamarind in a cup of water and strain. Keep aside. Prepare tadka in a microwave oven safe bowl as explained in Insta 3 with all the ingredients other than red gram dal and water. Remove, add the remaining ingredients and mix well. Place the bowl in the microwave oven, select Insta 5, enter weight and press start. Remove, and serve hot.			

PONGAL	Insta 5	PONGAL	100 g	200g	300g
		Ingredients:			
		Rice	1 cup	1½ cup	2 cup
		Moong Dal	¼ cup	½ cup	½ cup
		Cashew Nuts	few	few	few
		Black Peppers	few	few	few
		Grated Ginger	½ tsp	½ tsp	1 tsp
		Ghee As Required			
		Salt To Taste			
		Water As Required			
		Method of preparation			
		Prepare tadka in a microwave oven safe bowl as explained in Insta 3, with all the ingredients other than rice and water. After beep, remove, add the remaining ingredients and mix well. Place the bowl in the microwave oven, select Insta 5, enter weight and press start. For better result stir twice in between.			

VEG - PULAO	Insta 5	VEG - PULAO	100 g	200g	300g
		Ingredients:			
		rice (soaked)	1 cup	2 cup	3 cup
		potato cut into cubes	½ cup	¾ cup	1cup
		carrot cut into cubes	½ cup	¾ cup	1cup
		cauliflower cut into florets	½ cup	¾ cup	1cup
		peas	½ cup	¾ cup	1cup
		cashew nuts	½ tbsp	¾ tbsp	1 tbsp
		raisins	1 tsp	1½ tsp	2 tsp
		onions	1	1	1½
		ghee	1 tbsp	1 tbsp	1½ tbsp
		turmeric powder	¼ tsp	½ tsp	¾ tsp
		ginger paste	½ tsp	¾ tsp	1 tsp
		garlic paste	½ tsp	¾ tsp	1 tsp
		green chilli paste	½ tsp	¾ tsp	1 tsp
		chinnamon stick	1	2	3
		cloves	3	4	5
		mint leaves	¼ tbsp	½ tbsp	¾ tbsp
		cardamom	3	4	5
		oil as required			
		salt to taste			
		Method of preparation			
		Prepare tadka in a microwave oven safe bowl as explained in Insta 3 with all the ingredients other than rice, cashew and raisins. Remove. add the remaining ingredients, mix well. Place the bowl in the microwave oven, select Insta 5, enter weight and press start.			

RICE KHEER	Insta 5	RICE KHEER	100 g	200g	300g
		Ingredients:			
		rice	2 cup	3 cup	4 cup
		milk	2 cup	3 cup	4 cup
		cardamom seeds	few	few	few
		almonds	few	few	few
		saffron threads, soaked	a pinch	a pinch	a pinch
		pistachio nuts	few	few	few
		raisins (optional)	few	few	few
		sugar			
		Method of preparation			
		Take a microwave oven safe bowl, add all the ingredients other than saffron, mix well. Place the bowl in the microwave oven, select Insta 5, enter weight and press start.			

BISI BELE RICE	Insta 5	BISI BELE RICE	100 g	200g	300g
		Ingredients:			
		Red gram dal	½ cup	¾ cup	1 cup
		Rice	1 cup	2 cup	3 cup
		Brinjals chopped	2	3	4
		Tamarind juice	½ cup	¾ cup	1 cup
		Hing	a pinch	a pinch	a pinch
		Oil as required			
		Salt to taste			
		Paste ingredients			
		Onion	1	2	2
		Green chillies	1 tsp	1½ tsp	2 tsp
		Cashewnuts	½ cup	¾ cup	1 cup
		Grated coconut	½ cup	¾ cup	1 cup
		Khus khus	½ cup	¾ cup	1 cup
		Curry leaves	few	few	few
		Coriander leaves	½ cup	¾ cup	1 cup
		Powdered ingredients			
		Dry red chillies	3	4	5
		Fenugreek seeds	1 tsp	1½ tsp	2 tsp
		Coriander seeds	½ tsp	¾ tsp	1 tsp
		Mustard	½ tsp	¾ tsp	1 tsp
		Cardamoms	3	4	5
		Cinnamon	1	2	3
		Cloves	3	4	5
		Saunf	1 tsp	1½ tsp	2 tsp
		Method of preparation			
		Prepare tadka in a microwave oven safe bowl in Insta 3 with the paste ingredients. Remove. add the remaining ingredients and powdered ingredients also in it, mix well. Place the bowl in the microwave oven, select Insta 5, enter weight and press start. Remove and serve hot.			

YAM CHANNA PORIYAL	Insta 5	YAM CHANNA PORIYAL	100 g	200g	300g
		Ingredients:			
		yam	50 gms	100 gms	150 gms
		chana	50 gms	100 gms	150 gms
		tomato	1	1	1½
		urad dal	1 tsp	1½ tsp	2 tsp
		onion	2	2½	3
		garlic paste	½ tsp	¾ tsp	1 tsp
		ginger paste	½ tsp	¾ tsp	1 tsp
		turmeric powder	¼ tsp	¼ tsp	½ tsp
		red chilli powder	1 tsp	1½ tsp	2 tsp
		mustard seeds	¼ tsp	¼ tsp	½ tsp
		curry leaves	few	few	few
		oil as required			
		salt to taste			
		Method of preparation			
		Prepare tadka in a microwave oven safe bowl as explained in Insta 3 with all the ingredients other than yam and tomato. Remove. add the remaining ingredients, mix well. Place the bowl in the microwave oven, select Insta 5, enter weight and press start.			

KOOTTU CURRY	Insta 5	KOOTTU CURRY	100 g	200g	300g
		Ingredients:			
		bengal gram dal (channa dal)	½ cup	¾ cup	1 cup
		white gram dal (urad dal)	1 tbsp	1 tbsp	1½ tbsp
		pumpkin (cut into small pieces)	½ cup	¾ cup	1 cup
		snake gourd (cut into small pieces)	½ cup	¾ cup	1 cup
		french beans (cut into small pieces)	½ cup	¾ cup	1 cup
		yam (cut into small pieces)	½ cup	¾ cup	1 cup
		cucumber (cut into small pieces)	½ cup	¾ cup	1 cup
		inner flesh of drum stick pieces	½ cup	¾ cup	1 cup
		grated coconut paste	½ cup	¾ cup	1 cup
		turmeric powder	¼ tsp	½ tsp	¾ tsp
		green chillies paste	½ tsp	¾ tsp	1 tsp
		mustard seeds	¼ tsp	½ tsp	¾ tsp
		dried red chillies	3	4	5
		curry leaves	few	few	few
		ghee or coconut oil	1 tbsp	1½ tbsp	2 tbsp
		salt to taste			
		Method of preparation			
		Prepare tadka in a microwave oven safe bowl as explained in Insta 3 with all the ingredients other than all dal and all vegetable ingredients. After beep, Remove. add the remaining ingredients, mix well. Place the bowl in the microwave oven, select Insta 5, enter weight and press start.			

PARSI DAL	Insta 5	PARSI DAL	100 g	200g	300g
		Ingredients:			
		soaked red gram (tur dal)	1½ cup	2 cup	3 cup
		butter	1 tbsp	1 tbsp	1½ tbsp
		garlic	½ tsp	¾ tsp	1 tsp
		cumin seeds	½ tsp	¾ tsp	1 tsp
		turmeric powder	½ tsp	½ tsp	¾ tsp
		salt to taste			
		water as required			
		Method of preparation			
		Prepare tadka in a microwave oven safe bowl as explained in Insta 3 with all the ingredients other than red gram dal, water, and salt. Remove, add the remaining ingredients and mix well. Place the bowl in the microwave oven, select Insta 5, enter weight and press start. Remove, and serve hot.			

ACHARI MUTTON	Insta 5	ACHARI MUTTON	100 g	200g	300g
		Ingredients:			
		mutton	100 gms	200 gms	300 gms
		tomatoes	1	1	2
		onions	1	1	2
		fenugreek seeds	½ tsp	¾ tsp	1 tsp
		fennel seeds	½ tsp	¾ tsp	1 tsp
		cumin seeds	½ tsp	¾ tsp	1 tsp
		turmeric powder	¼ tsp	½ tsp	½ tsp
		dried red chilli	2	2	3
		red chilli powder	1 tsp	1½ tsp	2 tsp
		cloves	2	3	4
		ginger, garlic paste	1 tsp	1½ tsp	2 tsp
		mustard seeds	½ tsp	¾ tsp	1 tsp
		coriander leaves for garnish			
		oil as required			
		salt to taste			
		Method of preparation			
		Prepare tadka in a microwave oven safe bowl as explained in Insta 3 with all the ingredients other than mutton, tomato and coriander leaves. Remove. add the remaining ingredients other than coriander leaves and mix well. Place the bowl in the microwave oven, select Insta 5, enter weight and press start. Remove, and garnish with coriander leaves. serve hot.			

GAJAR HALWA	Insta 5	GAJAR HALWA	100 g	200g	300g
		Ingredients:			
		carrots (grated)	1½ cup	2 cup	2½ cup
		kawa (mawa grated)	½ cup	¾ cup	¾ cup
		sugar	1½ cup	1½ cup	2 cup
		milk condensed	½ cup	¾ cup	¾ cup
		milk	½ cup	¾ cup	¾ cup
		cardamoms	few	few	few
		pistachio flakes (almonds)	few	few	few
		ghee as required			
		raisins	few	few	few
		Method of preparation:			
		Prepare tadka in a microwave oven safe bowl as explained in Insta 3 with all the ingredients other than milk, condensed milk, cardamom, flakes and raisins. After beep, remove, add the remaining ingredients and mix well. Place the bowl in the microwave oven select Insta 5, enter weight and press start.			

LENTIL SOUP	Insta 5	LENTIL SOUP	100 g	200g	300g
		Ingredients:			
		split lentils	1½ cup	2 cup	2½ cup
		garlic,ginger paste	1 tsp	1½ tsp	2 tsp
		red chilli powder	1 tsp	1½ tsp	2 tsp
		turmeric powder	¼ tsp	½ tsp	½ tsp
		green chili, chopped	2	3	3
		salt to taste			
		coriander leaves for garnish			
		water as required			
		Method of preparation:			
		Prepare tadka in a microwave oven safe bowl as explained in Insta 3 with all the ingredients other than lentil, water and coriander leaves. Remove. add the remaining ingredients other than coriander leaves and mix well. Place the bowl in the microwave oven, select Insta 5, enter weight and press start. Remove, and garnish with coriander leaves. serve hot.			

KASHMIRI PULAO	Insta 5	KASHMIRI PULAO	100 g	200g	300g
		Ingredients:			
		Rice	1½ cup	2 cup	2½ cup
		Cinnamon	2 stick	3 stick	4 stick
		Cardamom	4	5	6
		Cloves	3	4	5
		Turmeric powder	¼ tsp	½ tsp	½ tsp
		Saffron	a pinch	a pinch	a pinch
		Milk	½ cup	¾ cup	¾ cup
		Walnut for garnish	few	few	few
		Cashew nut for garnish	few	few	few
		Onion fried for garnish			
		Water as required			
		Oil as required			
		Salt to taste			
Method of preparation:					
Prepare tadka in a microwave oven safe bowl as explained in Insta 3 with all the ingredients other than rice , water and all garnished ingredients. Remove. add the remaining ingredients other than garnished ingredients and mix well. Place the bowl in the microwave oven, select Insta 5, enter weight and press start. Remove, garnish and serve hot.					

CHANA BIRYANI	Insta 5	CHANA BIRYANI	100 g	200g	300g
		Ingredients:			
		Rice	1½ cup	2 cup	2½ cup
		Channa	¾ cup	1 cup	1½ cup
		Onion	1	2	2
		Tomato	1	2	2
		Potato	1	2	2
		Chilli powder	1 tsp	1½ tsp	2 tsp
		Green chillies	2	3	4
		Turmeric powder	¼ tsp	½ tsp	½ tsp
		Ginger garlic paste	1 tsp	1½ tsp	2 tsp
		Cinnamon	2 stick	3 stick	4 stick
		Curry leaves	few	few	few
		Bay leaf	2	3	4
		Cloves	3	4	5
		Salt – to taste			
		Butter as required			
Method of preparation:					
Prepare tadka in a microwave oven safe bowl as explained in Insta 3 with all the ingredients other than rice , water and tomato. After beep, remove, add the remaining ingredients and mix well. Place the bowl in the microwave oven, select Insta 5, enter weight and press start.					

BEANS RICE	Insta 5	BEANS RICE	100 g	200g	300g
		Ingredients:			
		rice	1½ cup	2 cup	2½ cup
		black beans	¾ cup	1 cup	1½ cup
		onion, chopped	1	2	2
		capsicum, thinly sliced	1	2	2
		garam masala	1 tsp	1½ tsp	2 tsp
		pepper powder	1 tsp	1½ tsp	2 tsp
		garlic paste	½ tsp	¾ tsp	1 tsp
		red chilli powder	1 tsp	1½ tsp	2 tsp
		oil as required			
		coriander leaves for garnish			
		salt as required			
Method of preparation:					
Prepare tadka in a microwave oven safe bowl as explained in Insta 3 with all the ingredients other than rice , black beans and coriander leaves.After beep, remove and add the remaining ingredients other than coriander leaves and mix well. Place the bowl in the microwave oven, select Insta 5, enter weight and press start. Remove, garnish with coriander leaves.serve hot.					

TADKA DAL	Insta 5	TADKA DAL	100 g	200g	300g
		Ingredients:			
		red lentils (masoor dal)	1 cup	1½ cup	2 cup
		yellow lentils (moong dal)	1 cup	1½ cup	2 cup
		tomato chopped	2	3	3
		onion chopped	1	1½	2
		oil	1 tbsp	1 tbsp	1½ tbsp
		red chilli powder	1 tsp	1½ tsp	2 tsp
		turmeric powder	¼ tsp	¼ tsp	½ tsp
		ginger paste	½ tsp	¾ tsp	1 tsp
		garlic paste	½ tsp	¾ tsp	1 tsp
		green chillies chopped	2	3	4
		musturd seeds	¼ tsp	¼ tsp	½ tsp
		dried red chillies	2	3	4
		coriander leaves for garnish			
		salt to taste			
		water as required			
Method of preparation					
Prepare tadka in a microwave oven safe bowl as explained in Insta3 with all the ingredients other than red lentils, yellow lentils, tomato, water and salt.Remove, add the remaining ingredients and mix well. Place the bowl in the microwave oven, select Insta 5, enter weight and press start. Remove, garnish with coriander leaves and serve hot.					

SINDHI CURRY	Insta 5	SINDHI CURRY	100 g	200g	300g
		Ingredients:			
		chopped carrots	¼ cup	½ cup	¾ cup
		chopped potatoes	¼ cup	½ cup	¾ cup
		chopped cauliflower	¼ cup	½ cup	¾ cup
		chopped eggplant	¼ cup	½ cup	¾ cup
		chopped okra	¼ cup	½ cup	¾ cup
		besan	1 tbsp	1½ tbsp	1½ tbsp
		cumin seeds roasted	½ tsp	¾ tsp	1 tsp
		methi seeds roasted	½ tsp	¾ tsp	1 tsp
		hing	a pinch	a pinch	a pinch
		turmeric powder	¼ tsp	¼ tsp	½ tsp
		red chilli powder	1tsp	1½ tsp	2 tsp
		tamarind paste juice	½ cup	¾ cup	1 cup
		curry leaves	few	few	few
		green chilli	2	3	4
		chopped ginger	½ tsp	½ tsp	¾ tsp
		oil as required			
		salt to taste			
		warm water			
		chopped coriander for garnish			
		chopped mint for garnish			
		Method of preparation			
		Prepare tadka in a microwave oven safe bowl as explained in Insta 3 with all the ingredients other than hing, tamarind juice, water and coriander, mint leaves. After beep, remove and add the remaining ingredients other than coriander, mint leaves and mix well. Place the bowl in the microwave oven, select Insta 5, enter weight and press start. Remove, garnish with coriander, mint leaves. serve hot.			

KICHURI	Insta 5	KICHURI	100 g	200g	300g
		Ingredients:			
		Rice	1 cup	1½ cup	2 cup
		Moong dal roasted	½ cup	¾ cup	1 cup
		Cauliflower florets	¼ cup	½ cup	¾ cup
		Green peas	¼ cup	½ cup	¾ cup
		Potatoes (cubed)	¼ cup	½ cup	¾ cup
		Chilli powder	1tsp	1½ tsp	2 tsp
		Sugar	1tsp	1½ tsp	2 tsp
		Turmeric powder	¼ tsp	¼ tsp	½ tsp
		Green chillies	2	3	4
		Cumin powder	1tsp	1½ tsp	2 tsp
		Bay Leaves	2	3	4
		Red Chillies Whole	2	3	4
		Green Cardamoms	3	4	5
		Cloves	2	3	4
		Cinnamon	1" stick	1½" stick	2" stick
		Ghee as required			
		salt to taste			
		water as required			
		Method of preparation			
		Prepare tadka in a microwave oven safet bowl as explained in Insta3 with all the ingredients other than vegetables and water. After beep, remove, add the remaining ingredients and mix well. Place the bowl in the microwave oven, select Insta 5, enter weight and press start. serve hot.			

AAMTI	Insta 5	AAMTI	100 g	200g	300g
		Ingredients:			
		moong dal	1½ cup	2 cup	2½ cup
		chopped tomato	1 cup	1½ cup	2 cup
		green chillies	3	4	5
		curry leaves	few	few	few
		mustard seeds	½ tsp	¾ tsp	1 tsp
		hing	a pinch	a pinch	a pinch
		turmeric powder	¼ tsp	½ tsp	½ tsp
		cumin seeds	½ tsp	¾ tsp	1 tsp
		oil as required			
		salt to taste			
		water as required			
		coriander leaves for garnish			
		Method of preparation			
		Prepare tadka in a microwave oven safe bowl as explained in Insta 3 with all the ingredients other than moong dal. tomato, hing, coriander leaves and water. After beep, remove, add the remaining ingredients other than coriander leaves and mix well. Place the bowl in the microwave oven, select Insta 5, enter weight and press start. remove and garnish with coriander leaves. serve hot.			

MUTTON CURRY	Insta 5	MUTTON CURRY	100 g	200g	300g
		Ingredients:			
		Mutton	1½ cup	2 cup	2½ cup
		Tomato (Chopped)	¾ cup	1 cup	1 cup
		Red chili powder	1tsp	1½ tsp	2 tsp
		Onions (Chopped)	¾ cup	1 cup	1 cup
		Black Pepper Powder	½ tsp	¾ tsp	1 tsp
		Turmeric Powder	1"stick		
		Cinnamon	1tsp	1½ tsp	2 tsp
		Coriander seeds	1tsp	1½ tsp	2 tsp
		Cumin seeds	½ tsp	¾ tsp	1 tsp
		Cloves	2	3	4
		Green Cardamoms	3	4	5
		Ginger and Garlic Paste.	1tsp	1½ tsp	2 tsp
		Curry Leaves	few	few	few
		Poppy Seeds	few	few	few
		Fennel Seeds	½ tsp	¾ tsp	1 tsp
		Black Peppercorns	½ tsp	¾ tsp	1 tsp
		Oil as required			
		Salt to taste			
		Coriander Leaves for garnish			
Method of preparation					
<p>Prepare tadka in a microwave oven safet bowl as explained in Insta 3 with all the ingredients other than mutton. tomato and coriander leaves. After beep, remove, add the remaining ingredients other than coriander leaves and mix well. Place the bowl in the microwave oven, select Insta 5, enter weight and press start. remove and garnish with coriander leaves. serve hot.</p>					

MEAT BALLS	Insta 6	MEAT BALLS	100 g	200g	300g
		Ingredients:			
		meat	150 gms	300 gms	450 gms
		eggs	1	2	2
		bread crumbs	¼ cup	1 cup	1½ cup
		garlic paste	½ tsp	¾ tsp	1 tsp
		onion (minced)	½ cup	¾ cup	1 cup
		milk	½ cup	¾ cup	1 cup
		tomato sauce	1 tbsp	1 tbsp	1½ tbsp
		sugar	1 tsp	1½ tsp	2 tsp
		mustard	½ tsp	¾ tsp	1 tsp
		pepper to taste	1 tsp	1½ tsp	2 tsp
		oil as required			
		salt to taste.			
		Method of preparation			
		Blend all ingredients together. Make meat balls. Arrange meat balls in a microwave oven safe glass wide bowl, select Insta 6, enter weight and press start. Stir once in between.			

CHICKEN 65	Insta 6	CHICKEN 65			
		Ingredients:			
		Boneless skinless chicken	150 gms	300 gms	450 gms
		cloves,	few	few	few
		cinnamon	few	few	few
		cardamom	few	few	few
		Garlic paste	½ tsp	½ tsp	¾ tsp
		Ginger paste	½ tsp	½ tsp	¾ tsp
		Red chilies powder	1 tsp	1½ tsp	2 tsp
		All-purpose flour	1 tsp	1½ tsp	2 tsp
		Egg	1	1	2
		food coloring, red	a pinch	a pinch	a pinch
		yoghurt	½ cup	½ cup	1 cup
		Green chilies	1	2	2
		Cornflour	1 tbsp	1 tbsp	1½ tbsp
		Lime juice	1 tsp	1½ tsp	2 tsp
		Butter as required			
		Salt to taste			
		Method of preparation:			
		Marinate the chicken with the all ingredients for 1 hour. In a microwave oven safe wide glass bowl add all marinate ingredients, Place the bowl in the microwave oven select Insta 6, enter weight and press start.			

CHEESE CORN BALLS	Insta 6	CHEESE CORN BALLS			
		Ingredients:			
		boiled sweet corn kernels,	1½ cup	2 cup	2½ cup
		cheese grated	½ cup	½ cup	1 cup
		potatoes,boiled and mashed	½ cup	½ cup	1 cup
		capsicum,	½ cup	½ cup	1 cup
		breadcrumbs	1 cup	1½ cup	2 cup
		maida	1 tbsp	1 tbsp	1½ tbsp
		cornflour,	1 tbsp	1 tbsp	1½ tbsp
		oregano,	few	few	few
		oil as required			
		salt to taste,			
		Method of preparation:			
		Blend all ingredients together. Make corn balls. Arrange corn balls in a microwave oven safe glass wide bowl, select Insta 6, enter weight and press start. turn once in between.			

VEGETABLE CUTLETS	Insta 6	VEGETABLE CUTLETS			
		Ingredients:			
		Potatoes boiled	1 cup	1½ cup	2 cup
		Green Peas boiled	¼ cup	½ cup	½ cup
		Beans boiled	¼ cup	½ cup	½ cup
		Beetroort boiled	¼ cup	½ cup	½ cup
		Corn flour	¼ cup	½ cup	½ cup
		Dry Mango Powder	1 tsp	1½ tsp	2 tsp
		Red chilli powder	1 tsp	1½ tsp	2 tsp
		Oil as required			
		Salt to taste			
		Coriander leaves for garnish			
		Method of preparation:			
		Blend all boiled ingredients together. Mash them lightly. Add all remaining ingredient mix well shape as a mediem sized cutlets. Arrange cutlets in a lightly greased baking tray, place the tray on the mesh rack in the microwave oven, select Insta 6, enter weight and press start. turn once in between.			

KHEEMA CUTLETS	Insta 6	KHEEMA CUTLETS			
		Ingredients:			
		Mutton Kheema cooked	1½ cup	2 cup	2½ cup
		Potatoes boiled	1½ cup	2 cup	2½ cup
		Besan flour	½ cup	½ cup	1 cup
		Onion, chopped thinly	½ cup	½ cup	1 cup
		Cloves	2	3	4
		Cinnamon sticks	2	3	3
		Cardamoms	3	4	5
		Garlic flakes	3	4	5
		Ginger, grated	½ tsp	½ tsp	¾ tsp
		Poppy Seeds	½ tsp	½ tsp	¾ tsp
		Eggs	1	2	2
		Turmeric powder	¼ tsp	½ tsp	½ tsp
		Red chillie powder	1 tsp	1½ tsp	2 tsp
		Curry leaves chopeed	few	few	few
		Coriander leaves chopped	few	few	few
		Oil as required			
		Salt as required			
		Method of preparation:			
		Prepare tadka in a microwave oven safe bowl as explained in Insta 3 with all the ingredients other than eggs and corn flour. After beep, remove, and add the remaining ingredients, mix and grind well to make kheema cutlets. Arrange cutlets in a lightly greased baking tray, place the tray on the mesh rack in the microwave oven, select Insta 6, enter weight and press start. turn once in between.			

CHICKEN LOLLYPOPS	Insta 6	CHICKEN LOLLYPOPS			
		Ingredients:			
		chicken wings	150 gms	300 gms	450 gms
		maida	1 tbsp	1½ tbsp	2 tbsp
		eggs	1	2	2
		soya sauce	1 tbsp	1½ tbsp	2 tbsp
		green chilli paste	1 tsp	1½ tsp	2 tsp
		ginger, garlic paste	½ tsp	½ tsp	¾ tsp
		garam masala	1 tsp	1½ tsp	2 tsp
		pepper powder	1 tsp	1½ tsp	2 tsp
		chillie sauce	1 tbsp	1½ tbsp	2 tbsp
		red color			
		oil as required			
		salt to taste			
		Method of preparation:			
		Marinate the chicken with the all ingredients for 1 hour. Arrange the marinate chicken in a lightly greased baking dish and place the baking dish on the mesh rack in the microwave oven, select Insta 6, enter weight and press start.turn once in between.			

BAKED MUSHROOM	Insta 6	BAKED MUSHROOM			
		Ingredients:			
		Mushrooms	1½ cup	2 cup	2½ cup
		Pepper Powder	1 tsp	1½ tsp	2 tsp
		Bread crumbs	1 cup	1½ cup	2 cup
		Cheese grated	1 tbsp	1½ tbsp	2 tbsp
		Coriander leaves	1 tbsp	1½ tbsp	2 tbsp
		Lemon Juice	1 tsp	1½ tsp	2 tsp
		Garlic paste	½ tsp	½ tsp	¾ tsp
		Olive Oil			
		Salt to taste			
		Method of preparation:			
		Mix all ingredients to the mushrooms and marinate for 20 minutes. Arrange the marinated mushrooms in a lightly greased wide glass bowl and place the bowl in the microwave oven, select Insta 6, enter weight and press start. turn once in between.			

FISH CUTLETS	Insta 6	FISH CUTLETS			
		Ingredients:			
		Fish boiled & bones removed	150 gms	300 gms	450 gms
		Egg	1	2	2
		Bread slices soaked in water	2	3	4
		Garlic paste	½ tsp	½ tsp	¾ tsp
		Ginger paste	½ tsp	½ tsp	¾ tsp
		Bread Crumbs	1 tbsp	1½ tbsp	2 tbsp
		Green Chillies	2	3	3
		Corn Flour	1 tbsp	1½ tbsp	2 tbsp
		Garam Masala	1 tbsp	1½ tbsp	2 tbsp
		Turmeric Powder	¼ tsp	½ tsp	½ tsp
		Coriander Leaves	1 tbsp	1½ tbsp	2 tbsp
		Salt to taste			
		Oil as required			
		Method of preparation:			
		Mash the fish and bread slices gently with the hands and add all ingredients together other than eggs, bread crumbs and mash them lightly. Add all remaining ingredient mix well shape as a medium sized cutlets. Arrange cutlets in a lightly greased baking tray, place the tray on the mesh rack in the microwave oven, select Insta 6, enter weight and press start. turn once in between.			

ALOO TIKKI	Insta 6	ALOO TIKKI			
		Ingredients:			
		boiled aloo	150 gms	300 gms	450 gms
		green peas cooked	1 cup	1½ cup	2 cup
		black pepper powder	½ tsp	¾ tsp	1 tsp
		ginger paste	½ tsp	¾ tsp	1 tsp
		garam masala	1 tsp	1½ tsp	2 tsp
		red chili powder	1 tsp	1½ tsp	2 tsp
		cumins powder	1 tsp	1½ tsp	2 tsp
		oil as required			
		salt or to taste			
		Method of preparation:			
		Mash potatoes and green peas together. Add all remaining ingredient mix well and shape as a medium sized tikki. Arrange tikki in a lightly greased baking tray, place the tray on the mesh rack in the microwave oven, select Insta 6, enter weight and press start. turn once in between.			

CHICKEN ROAST	Insta 6	CHICKEN ROAST			
		Ingredients:			
		chicken	150 gms	300 gms	450 gms
		garlic paste	1 tsp	1½ tsp	2 tsp
		ground black pepper	1 tsp	1½ tsp	2 tsp
		lemon juice	1 tsp	1½ tsp	2 tsp
		thyme	1 tsp	1½ tsp	2 tsp
		oil as required			
		salt to taste			
		Method of preparation:			
		Marinate the chicken with the all ingredients for 1 hour. Arrange the marinate chicken in a lightly greased baking dish and place the baking dish on the mesh rack in the microwave oven, select Insta 6, enter weight and press start.turn once in between.			

RESHMI KABAB	Insta 6	RESHMI KABAB			
		Ingredients:			
		boneless chicken	150 gms	300 gms	450 gms
		garlic paste	1 tsp	1½ tsp	2 tsp
		ginger paste	1 tsp	1½ tsp	2 tsp
		coriander leaves paste	1 tbsp	1½ tpb	2 tbsp
		onions paste	1 tbsp	1½ tpb	2 tbsp
		yoghurt	1 cup	1½ cup	2 cup
		almonds grated	1 tbsp	1½ tpb	2 tbsp
		Juice of lemon	½	1	1
		salt to taste			
		oil as required			
		Method of preparation:			
		Marinate the chicken with the all ingredients for 2 hour. Arrange the marinate chicken in a lightly greased baking dish and place the baking dish on the mesh rack in the microwave oven, select Insta 6, enter weight and press start.turn once in between.			

BREAD PUDDING	Insta 6	BREAD PUDDING			
		Ingredients:			
		bread crumbs	150 gms	300 gms	450 gms
		sugar	150 gms	300 gms	450 gms
		milk	½ ltr	¾ ltr	1 ltr
		chocolate	100 gms	150 gms	200 gms
		eggs (yolks& white suppurate)	2	2	3
		vanilla essence	½ tsp	½ tsp	¾ tsp
		butter as required			
		Method of preparation:			
		Soak bread crumbs in milk and press dry, add butter mixed sugar, chocolate, egg yolks, Mix well and add vanilla essence, egg white, mix all ingredients well and set a side for 15 minutes.Pour the pudding in lightly greased wide glass bowl and place in the microwave. Select Insta 6, enter weight and press start.			

MUTTON ROAST	Insta 7	MUTTON ROAST				
		Ingredients:				
		mutton, cut into pieces	800 gms	1000 gms	1200 gms	1400 gms
		curd,	1½ cup	2 cup	2½ cup	3 cup
		ginger, garlic paste,	1 tsp	1½ tsp	2 tsp	2 tsp
		coriander powder,	1 tsp	1½ tsp	2 tsp	2 tsp
		black pepper powder,	1 tsp	1½ tsp	2 tsp	2 tsp
		red chilly powder,	2 tsp	2½ tsp	3 tsp	3 tsp
		garam masala	2 tsp	2½ tsp	3 tsp	3 tsp
		ghee as required				
		salt to taste.				
		Method of preparation:				
		In a mixing bowl add all the ingredients, mix it all together. Let it marinate for five hours. Take the marinate mutton into a lightly greased wide glass bowl, Place the the bowl in the microwave oven, select Insta 7, enter weight and press start. Turn once in between.				

CHICKEN TANDOORI	Insta 7	CHICKEN TANDOORI				
		Ingredients:				
		chicken	800 gms	1000 gms	1200 gms	1400 gms
		garlic paste	1 tsp	1½ tsp	2 tsp	2 tsp
		ginger paste	1 tsp	1½ tsp	2 tsp	2 tsp
		green chillies paste	1 tsp	1½ tsp	2 tsp	2 tsp
		pumpkin paste	1½ cup	2 cup	2½ cup	3 cup
		lime juice	½ tsp	½ tsp	¾ tsp	1 tsp
		curd	1½ cup	2 cup	2½ cup	3 cup
		red chilli powder	1 tsp	1½ tsp	2 tsp	2 tsp
		orange colour	½ tsp	½ tsp	¾ tsp	1 tsp
		kashmiri chilli powder	1 tsp	1½ tsp	2 tsp	2 tsp
		butter as required				
		salt to taste				
		Method of preparation:				
		Marinate the chicken with all ingredients, mix well and set aside for 2 hour. Arrange the chicken in a lightly greased wide glass bowl and place the glass bowl in the microwave oven, select Insta 7, enter weight and press start.				

WHOLE CHICKEN ROAST	Insta 7	WHOLE CHICKEN ROAST				
		Ingredients:				
		chicken	800 gms	1000 gms	1200 gms	1400 gms
		ground black pepper	1 tsp	1½ tsp	2 tsp	2 tsp
		cumins powder	1 tsp	1½ tsp	2 tsp	2 tsp
		garam masala	1 tsp	1½ tsp	2 tsp	2 tsp
		onion paste	1½ cup	2 cup	2½ cup	3 cup
		red chilli powder	1 tsp	1½ tsp	2 tsp	2 tsp
		garlic, ginger paste	1 tsp	1½ tsp	2 tsp	2 tsp
		lemon juice as required				
		oil as required				
		salt to taste				
		Method of preparation:				
		Marinate the chicken with all ingredients, mix well and set aside for 2 hour. Arrange the chicken in a lightly greased wide glass bowl and place the glass bowl in the microwave oven, select Insta 7, enter weight and press start.				

MUTTON KEBAB	Insta 7	MUTTON KEBAB				
		Ingredients:				
		Mutton, cut into 1-1½ " pieces	800 gms	1000 gms	1200 gms	1400 gms
		Coriander powder	1 tsp	1½ tsp	2 tsp	2 tsp
		Khus Khus grinded	2 tsp	2½ tsp	3 tsp	4 tsp
		Cumin powder	1 tsp	1½ tsp	2 tsp	2 tsp
		Curd	1½ cup	2 cup	2½ cup	3 cup
		Garlic Paste	1 tsp	1½ tsp	2 tsp	2 tsp
		Ginger Paste	1 tsp	1½ tsp	2 tsp	2 tsp
		Onion Paste	1 cup	1½ cup	2 cup	2½ cup
		Salt to taste				
		Method of preparation:				
		Marinate the mutton with all ingredients, mix well and set aside for 6 hours. Arrange the mutton in a lightly greased wide glass bowl and place the glass bowl in the microwave oven, select Insta 7, enter weight and press start.				

PODO PITHA	Insta 7	PODO PITHA			
		Ingredients:			
		Rice soaked	1 cup	1½ cup	2 cup
		Urad Dal soaked	1 cup	1½ cup	2 cup
		Grated coconut	1 cup	1½ cup	2 cup
		Sugar	1 cup	1½ cup	2 cup
		Ginger paste	1 tsp	1½ tsp	2 tsp
		Black pepper powder	1 tsp	1½ tsp	2 tsp
		Ghee as required			
		Salt to taste			
Method of preparation:					
Wash the dal and rice cleanly and grind it. The paste should be fine and thick. Add salt and mix well. keep aside for 2 hours. add all remaining ingredients to the rice and dal paste. mix well and pour in a lightly greased baking dish and place the baking dish in the microwave oven, select Insta 7, enter weight and press start.					

LITTI	Insta 7	LITTI			
		Ingredients:			
		wheat flour	1½ cup	2 cup	2½ cup
		ghee	½ cup	½ cup	¾ cup
		salt to taste			
		water as required			
		Fillings			
		sattu	1 cup	1½ cup	2 cup
		cumin seeds	1 tsp	1½ tsp	2 tsp
		hing	a pinch	a pinch	a pinch
		garam masala	1 tsp	1½ tsp	2 tsp
		chilli powder	½ tsp	½ tsp	¾ tsp
		powdered fennel seeds	1 tbsp	1½ tbsp	2 tbsp
		powdered coriander seeds	1 tsp	1½ tsp	2 tsp
		amchoor powder	½ tsp	½ tsp	¾ tsp
		oil as required			
		salt to taste			
Method of preparation:					
Mix the flour, salt, ghee and enough water to make a stiff dough. cover and set aside for 30 minutes. Mix all the filling ingredients together and Prepare tadka in a microwave oven safe bowl as explained in Insta 3 with all the filling ingredients, enter weight and press start. keep aside. Make smooth balls from the dough with filling in the center of the ball, Arrange the balls in a lightly greased baking dish and place the baking dish on the mesh rack in the microwave oven, select Insta 7, enter weight and press start. turn once in between.					

SPONGE CAKE	Insta 8	SPONGE CAKE	475 g
		Ingredients;	
		raising flour	5 cup
		ground sugar	3 cup
		eggs	4
		ghee	2 cup
		baking powder	1 tsp
		condensed milk	1 ½ cup
		chocolate powder	5 tsp
		vanilla essence	½ tsp
		Method of preparation:	
Prepare soft batter of all the ingredients mix well. Pour the mixture in the lightly greased baking dish, place the baking dish in the microwave oven select Insta 8, enter weight and press start.			

CARROT CAKE	Insta 8	CARROT CAKE	475 g
		Ingredients:	
		grated carrots	3 cup
		flour	1½ cup
		sugar	2½ cup
		cinnamon	few
		nut meg	few
		baking powder	1 tsp
		baking soda	½ tsp
		egg	3
		vanilla	½ tsp
		chopped walnuts	½ tsp
		ghee as required	
		Method of preparation:	
Take a mixing bowl, add all ingredients, mix well, set aside for 20 minutes.pour the mixture into a lightly greased glass bowl, place the bowl in oven and select Insta 8, enter weight, press start.			

APPLE CAKE	Insta 8	APPLE CAKE	475 g
		Ingredients:	
		finely grated apples	3 cup
		sugar	2 cup
		egg (beaten)	3
		flour	3 cup
		cinnamon	1 tsp
		baking powder	1½ tsp
		vanilla	1 tsp
		raisins (kismis)	1 cup
		nuts (chopped)	1 cup
		Method of preparation:	
Place apples in large mixing bowl, add sugar, stir and let stand for ½ hour. Add egg, flour, cinnamon, baking powder, nuts, and raisins, blend well. pour the mixture into a lightly greased glass bowl, place the bowl in oven and select Insta 8, enter weight, press start.			

PANEER CAKE	Insta 8	PANEER CAKE	475 g
		Ingredients:	
		panneer	3 cups
		Maida	1½ cup
		Sooji	2 tsp
		Milk	1 cup
		Sugar	1½ cup
		Butter as required	1½ tsp
		Cardamom powder	½ tsp
		Cooking soda	a pinch
Method of preparation:			
Place the mashed panneer in a large mixing bowl, add maida. sugar, Add egg, flour, cinnamon, baking powder, nuts, and raisins, blend well. pour the mixture into a lightly greased glass bowl, place the bowl in oven and select Insta 8, enter weight, press start.			

MICROWAVE OVEN WARRANTY

The Godrej Microwave Oven comes with a THREE years warranty on the magnetron and a ONE year warranty (except for plastic parts, glass components and decorative strips, knobs etc.) against defective material or workmanship on all components of the microwave oven. Godrej & Boyce Mfg. Co. Ltd. Appliance Division undertakes repairs, free of charge during the warranty period.

INSTRUCTIONS FOR THE CUSTOMER

1. Kindly ensure that the dealer fills the warranty details correctly and completely.
2. You should retain the warranty page for record and produce the same in the event of any warranty repairs.
3. In the event of a defect developing in the product, contact the nearest authorized Godrej & Boyce Service Centre for obtaining warranty service and inform the defect, model details and Serial No.

TERMS AND CONDITIONS

1. Repairs and replacement of parts will be carried out through the authorized customer service centre.
2. For units installed beyond the municipal limits of the jurisdiction of the authorized customer care centre all expenses incurred in collecting the units or parts thereof from the company's customer care centre, as well as expenses incurred with depositing of service personnel / technician's towards conveyance and other incidents will be borne by the customer.
3. The concerned customer care centre will advise the customer whether to effect the repair at site or at the customer care centre.
4. While the company will make every effort to carry out the repairs at the earliest, it however is made expressly clear that the company is under no obligation to do so in a specified period of time.
5. The company or its authorised customer care centre / service dealer reserves the right to retain any parts, components replaced at its discretion.
6. Warranty does not cover accessories to the equipment.
7. The warranty is confined to the first purchaser of MWO only and non-transferable.
8. Call registered with the centralized helpline / authorized service centre, where in only cleaning of the unit/ parts in the unit due to dust accumulation on portions of the units are not to be considered as defects.
9. **In case of any damages to the product, customer abuse, repairs by unauthorized personnel & misuse detected by the authorized service centre personnel, the warranty conditions are not applicable.**
10. If any colour internal or external components are replaced, effort will be made to ensure that the shades match with the original or other components. However, the replaced shades, pattern, tints may vary from the customer's unit due to usage of the unit. Any matching components changed at customer's request will be charged, except the component which is actually needed.
11. **The unit shall be operated with variation +/-5% of the rated voltage. Fluctuation beyond specified tolerance will not be covered under warranty. Customer shall not operate the product below 210V under any circumstances.**
12. Parts not covered - Main door, Glass, Bulb, Rubber, Plastic Components.
13. This warranty does not cover any type of painting, plating including rusting etc. or defects thereof.
14. **The Appliance or any part thereof is subjected to neglect, abuse or misuse, tampering, alteration, accident, fire, floods or other acts of God, or damage by rodents or insects, the COMPANY is not responsible for any damage caused to the appliance & Shall not be liable for any consequential loss or compensation. nor refund of purchase price or replacement of the appliance.**

Godrej & Boyce Mfg. Co. Ltd.- Appliance Division

WARRANTY DETAILS

MODEL NO.
UNIT SR. NO.

DATE OF PURCHASE

CUSTOMER'S NAME & ADDRESS _____ _____ _____ TEL. _____
--

DEALER'S NAME & ADDRESS _____ _____ _____ TEL. _____
--

Customer's Signature:

Dealer's Signature:

This card is valid only if it is filled in and stamped by our authorised dealer on the date of purchase.

Warranty is Void If:

1. The warranty card is not completed properly at the time of purchase.
2. The completed warranty card is not presented to the authorized personnel at the time of service of the product.
3. The microwave is not operated according to instructions given in the 'User Guide'.
4. Defects are caused by improper or reckless use, which shall be determined by the company personnel.
5. Any repair work carried out by persons other than authorised company personnel.
6. Defects caused beyond control like abnormal voltage, acts of God, or while in transit to service center or purchaser's residence.
7. The warranty is not valid in case the serial number is deleted, defaced or altered.
8. Damage to the microwave or any parts due to transportation or shifting is not covered by the warranty.
9. The warranty automatically expires after 12 month of original date of purchase, even if the microwave may not be in use for any time for whatever reasons during the warranty period.

GODREJ & BOYCE MFG. CO. LTD., Appliances Division

Branch	Address
Ahmedabad	4th Floor, APM Shopping Mall Near IOCL Petrol Pump, Shyamal-Karnavati, 100 ft. Road, Satellite, Ahmedabad - 380 015
Bangalore	3rd Floor, The Karnataka Film Chamber of Commerce Bldg. 28, 1st Main, Crescent Road, High Grounds Nr. Shivanand Circle, Bangalore - 560 001
Bhopal	217, Zone I, M.P. Nagar, Beh. Jyoti Talkies, Bhopal - 462 011
Bhubaneswar	Highway Complex, NH-5, Rudrapur, Bhubaneswar - 752 101
Chandigarh/Mohali	Plot No. A-40, Phase VIII-A, Industrial Area, Mohali - 160 059
Chennai	No. 1, Sidco Industrial Estate, Ambattur, Chennai - 600 098
Coimbatore	No. 585 - 590 3rd Floor, Sathya Towers, DB Road, R S Puram, Coimbatore - 641002
Delhi	Godrej Bhavan, 2nd Floor, Shershah Suri Marg, Mathura Road, Okhla, New Delhi - 110 065
Faridabad	Godrej Bhavan, 2nd Floor, Shershah Suri Marg, Mathura Road, Okhla, New Delhi - 110 065
Ghaziabad	Plot No. 229/230, Sardar Pashu Ahaar, Bulandshahar Road, Village-chaprola, Ghaziabad
Guwahati	Basundhara Enclave, 1st & 2nd Floor Ulubari, Guwahati - 781007
Hyderabad	201 & 202, Lala-1 Land Mark, 5-4-94 to 97, 2nd Floor, Above Digital Shoppo, Ranigunj, M.G. Road, Secunderabad -500 003
Jaipur	502-506, 5th Floor, Gaurav Towers, Malviya Nagar, Jaipur - 302 017
Kochi	2nd floor, Angels Arcade, South Kalamasserry, Near CUSAT PO Kochi - 682022
Kolkata	Plot-30, Block-GN, Sector-V, Salt Lake city, Kolkata - 700 091
Lucknow	C-3/3 & C-3/4, Sanjay Complex, Near All India Radio, Vidhan Sabha Marg, Lucknow-226001
Mumbai	Appliance Division, Plant 4, Pirojshahnagar, Vikhroli, Mumbai - 400 079
Nagpur	Dr. Bhiwapurkar Chamber, 2nd Floor, Opp. Yashwant Stadium, Dhantoli, Nagpur - 440 012
Patna	Grand Plaza 6th Floor, 6001-6004, Dakbunglow Crossing. Frazer Road. Patna-800001
Pune	Apollo Building Square, Plot No. 60, Survey No. 599, Sahaney Sujan Park, Lullanagar, Bibewadi Road, Pune - 411 040
Raipur	9/1, Besides Bharat Petrol Pump, Opp, Hotel Picadelly, Mahoba Bazaar, G.E. Road, Raipur - 492 001, Chhatisgarh
Ranchi	C/o. Surya Motors, Near Krishi Bazaar Samiti Pandra, Ranchi (Jharkand) - 835 222

Toll-Free :1800-209-5511

Website: www.godrejappliances.com & www.godrejsmartcare.comE-mail: smartcare@godrej.com

Protection of Environment:



"Protection of environment" is one of the core values of Godrej and we seek your co-operation to make sure that this product is not disposed as unsorted municipal waste.

This symbol is known as the "Crossed-out Wheelie Bin Symbol". It means that the product should not be disposed of with your general house-hold waste.

It should be disposed of only through the company's collection centers with special treatment so as to prevent any damage to the environment. **Please call: 1800 209 5511 or visit: www.godrejappliances.com/green-think for details about Godrej Appliances authorized collection centers.**

Godrej | APPLIANCES