

HOW TO GET THE BEST OUT OF YOUR GODREJ MICROWAVE OVEN...



User Manual

GME 728 CIP1 QM

28 Ltr. Inverter Microwave Convection

Thank you for purchasing Godrej Microwave Oven

Please record the model number and serial number of this unit for future reference. Staple your receipt here for proof of purchase.

Model No: _____

Serial No: _____

Dealer: _____

Dealer Phone No: _____

SPECIFICATIONS

Power Consumption:	230V~/50Hz, 1380W (Microwave)
	1100W (Grill)
	2500W (Convection)
Rated Microwave Output:	900W
Operating Frequency:	2450MHz
Product Dimensions: (W x H x D)	510 mm x 302 mm x 465 mm
Oven Capacity:	28L
Cooking Uniformity:	Turntable system
Net Weight:	14.20 Kg

TABLE OF CONTENT

PRECAUTIONS TO AVOID POSSIBLE EXPOSURE TO EXCESSIVE MICROWAVE ENERGY	4
IMPORTANT SAFETY INSTRUCTIONS WARNING	5
TO REDUCE THE RISK OF INJURY TO PERSONS GROUNDING INSTALLATION	8
CLEANING	9
UTENSILS	9
MATERIALS YOU CAN USE IN MICROWAVE OVEN	10
MATERIALS TO BE AVOIDED IN MICROWAVE OVEN	10
SETTING UP YOUR OVEN	11
TURNTABLE INSTALLATION	11
COUNTERTOP INSTALLATION	12
CONTROL PANEL	13
SELECTION OF BASIC FUNCTIONS	14
SELECTION OF COMBINATION MODE	15
VALID RECIPE NUMBERS FOR EACH AUTO COOK MENU	16
HOW ACM FUNCTIONS SHOULD WORK?	16
INSTACOOK MENU	18
TROUBLE SHOOTING	163
FREQUENTLY ASKED QUESTION	164
WARRANTY	165
BRANCHES ADDRESS	166

PRECAUTIONS TO AVOID POSSIBLE EXPOSURE TO EXCESSIVE MICROWAVE ENERGY

- (a) Do not attempt to operate this oven with the door open since this can result in harmful exposure to microwave energy. It is important not to break or tamper with the safety interlocks.
- (b) Do not place any object between the oven front face and the door or allow soil or cleaner residue to accumulate on sealing surfaces.
- (c) **WARNING:** If the door or door seals are damaged, the oven must not be operated until it has been repaired by a competent person.

ADDENDUM

If the apparatus is not maintained in a good state of cleanliness, its surface could be degraded and affect the life span of the apparatus and lead to a dangerous situation.

IMPORTANT SAFETY INSTRUCTIONS WARNING

To reduce the risk of fire, electric shock, injury to persons or exposure to excessive microwave oven energy when using your appliance, follow basic precautions, including the following:

1. Read and follow the specific: "PRECAUTIONS TO AVOID POSSIBLE EXPOSURE TO EXCESSIVE MICROWAVE ENERGY".
2. This appliance can be used by children aged from 8 years and above and persons with reduced physical, sensory or mental capabilities or lack of experience and knowledge if they have been given supervision or instruction concerning use of the appliance in a safe way and understand the hazards involved. Children shall not play with the appliance. Cleaning and user maintenance shall not be made by children unless they are older than 8 and supervised. Children less than 8 years of age shall be kept away unless continuously supervised.
3. Keep the appliance and its cord out of reach of children less than 8 years.
4. If the supply cord is damaged, it must be replaced by the manufacturer, its service agent or similarly qualified persons in order to avoid a hazard. (For appliance with type Y attachment)
5. **WARNING:** Ensure that the appliance is switched off before replacing the lamp to avoid the possibility of electric shock.
6. **WARNING:** It is hazardous for anyone other than a competent person to carry out any service or repair operation that involves the removal of a cover which gives protection against exposure to microwave energy.
7. **WARNING:** Liquids and other foods must not be heated in sealed containers since they are liable to explode.
8. When heating food in plastic or paper containers, keep an eye on the oven due to the possibility of ignition.
9. Only use utensils that are suitable for use in microwave ovens.
10. If smoke is emitted, switch off or unplug the appliance and keep the door closed in order to stifle any flames.
11. Microwave heating of beverages can result in delayed eruptive boiling, therefore care must be taken when handling the container.

12. The contents of feeding bottles and baby food jars shall be stirred or shaken and the temperature checked before consumption, in order to avoid burns.
13. Eggs in their shell and whole hard-boiled eggs should not be heated in microwave ovens since they may explode, even after microwave heating has ended.
14. The oven should be cleaned regularly and any food deposits removed.
15. Failure to maintain the oven in a clean condition could lead to deterioration of the surface that could adversely affect the life of the appliance and possibly result in a hazardous situation.
16. The appliance must not be installed behind a decorative door in order to avoid overheating. (This is not applicable for appliances with decorative door.)
17. Only use the temperature probe recommended for this oven. (for ovens provided with a facility to use a temperature-sensing probe.)
18. The microwave oven shall not be placed in a cabinet unless it has been tested in a cabinet.
19. The microwave oven must be operated with the decorative door open. (for ovens with a decorative door.)
20. This appliance is intended to be used in household and similar applications such as:
 - staff kitchen areas in shops, offices and other working environments;
 - by clients in hotels, motels and other residential type environments;
 - farm houses;
 - bed and breakfast type environments.
21. The microwave oven is intended for heating food and beverages. Drying of food or clothing and heating of warming pads, slippers, sponges, damp cloth and similar may lead to risk of injury, ignition or fire.
22. Metallic containers for food and beverages are not allowed during microwave cooking.
23. The appliance shall not be cleaned with a steam cleaner.
24. The appliance is intended to be used freestanding.
25. The rear surface of appliances shall be placed against a wall.

26. The appliances are not intended to be operated by means of an external timer or separate remote-control system.
27. The temperature of accessible surfaces may be high when the appliance is operating.
28. **WARNING:** When the appliance is operated in the combination mode, children should only use the oven under adult supervision due to the temperatures generated.

READ CAREFULLY AND KEEP FOR FUTURE REFERENCE

To Reduce the Risk of Injury to Persons Grounding Installation

DANGER

Electric Shock Hazard Touching some of the internal components can cause serious personal injury or death. Do not disassemble this appliance.

WARNING

Electric Shock Hazard Improper use of the grounding can result in electric shock. Do not plug into an outlet until appliance is properly installed and grounded. This appliance must be grounded. In the event of an electrical short circuit, grounding reduces the risk of electric shock by providing an escape wire for the electric current. This appliance is equipped with a cord having a grounding wire with a grounding plug. The plug must be plugged into an outlet that is properly installed and grounded. Consult a qualified electrician or serviceman if the grounding instructions are not completely understood or if doubt exists as to whether the appliance is properly grounded. If it is necessary to use an extension cord, use only a 3-wire extension cord.

1. A short power-supply cord is provided to reduce the risks resulting from becoming entangled in or tripping over a longer cord.
2. If a long cord set or extension cord is used:
 - 1) The marked electrical rating of the cord set or extension cord should be at least as great as the electrical rating of the appliance.
 - 2) The extension cord must be a grounding-type 3-wire cord.
 - 3) The long cord should be arranged so that it will not drape over the counter top or tabletop where it can be pulled on by children or tripped over unintentionally.

CLEANING

Be sure to unplug the appliance from the power supply.

1. Clean the cavity of the oven after using with a slightly damp cloth.
2. Clean the accessories in the usual way in soapy water.
3. The door frame and seal and neighbouring parts must be cleaned carefully with a damp cloth when they are dirty.
4. Do not use harsh abrasive cleaners or sharp metal scrapers to clean the oven door glass since they can scratch the surface, which may result in shattering of the glass.
5. **Cleaning Tip**---For easier cleaning of the cavity walls that the food cooked can touch: Place half a lemon in a bowl, add 300ml (1/2 pint) water and heat on 100% microwave power for 10 minutes. Wipe the oven clean using a soft, dry cloth.

UTENSILS

CAUTION

Personal Injury Hazard It is hazardous for anyone other than a competent person to carry out any service or repair operation that involves the removal of a cover which gives protection against exposure to microwave energy.

See the instructions on "Materials you can use in microwave oven or to be avoided in microwave oven." There may be certain non-metallic utensils that are not safe to use for microwaving. If in doubt, you can test the utensil in question following the procedure below.

Utensil Test:

1. Fill a microwave-safe container with 1 cup of cold water (250ml) along with the utensil in question.
2. Cook on maximum power for 1 minute.
3. Carefully feel the utensil. If the empty utensil is warm, do not use it for microwave cooking.
4. Do not exceed 1 minute cooking time.

Materials you can use in microwave oven

Utensils	Remarks
Aluminum foil	Shielding only. Small smooth pieces can be used to cover thin parts of meat or poultry to prevent overcooking. Arcing can occur if foil is too close to oven walls. The foil should be at least 1 inch (2.5cm) away from oven walls.
Browning dish	Follow manufacturer's instructions. The bottom of browning dish must be at least 3/16 inch (5mm) above the turntable. Incorrect usage may cause the turntable to break.
Dinnerware	Microwave-safe only. Follow manufacturer's instructions. Do not use cracked or chipped dishes.
Glass jars	Always remove lid. Use only to heat food until just warm. Most glass jars are not heat resistant and may break.
Glassware	Heat-resistant oven glassware only. Make sure there is no metallic trim. Do not use cracked or chipped dishes.
Oven cooking bags	Follow manufacturer's instructions. Do not close with metal tie. Make slits to allow steam to escape.
Paper plates and cups	Use for short-term cooking/warming only. Do not leave oven unattended while cooking.
Paper towels	Use to cover food for reheating and absorbing fat. Use with supervision for a short-term cooking only.
Parchment paper	Use as a cover to prevent splattering or a wrap for steaming.
Plastic	Microwave-safe only. Follow the manufacturer's instructions. Should be labeled "Microwave Safe". Some plastic containers soften, as the food inside gets hot. "Boiling bags" and tightly closed plastic bags should be slit, pierced or vented as directed by package.
Plastic wrap	Microwave-safe only. Use to cover food during cooking to retain moisture. Do not allow plastic wrap to touch food.
Thermometers	Microwave-safe only (meat and candy thermometers).
Wax paper	Use as a cover to prevent splattering and retain moisture.

Materials to be avoided in microwave oven

Utensils	Remarks
Aluminum tray	May cause arcing. Transfer food into microwave-safe dish.
Food carton with metal handle	May cause arcing. Transfer food into microwave-safe dish.
Metal or metal-trimmed utensils	Metal shields the food from microwave energy. Metal trim may cause arcing.
Metal twist ties	May cause arcing and could cause a fire in the oven.
Paper bags	May cause a fire in the oven.
Plastic foam	Plastic foam may melt or contaminate the liquid inside when exposed to high temperature.
Wood	Wood will dry out when used in the microwave oven and may split or crack.

SETTING UP YOUR OVEN

Names of Oven Parts and Accessories

Remove the oven and all materials from the carton and oven cavity. Your oven comes with the following accessories:

Glass tray	1
Turntable ring assembly	1
Instruction Manual	1

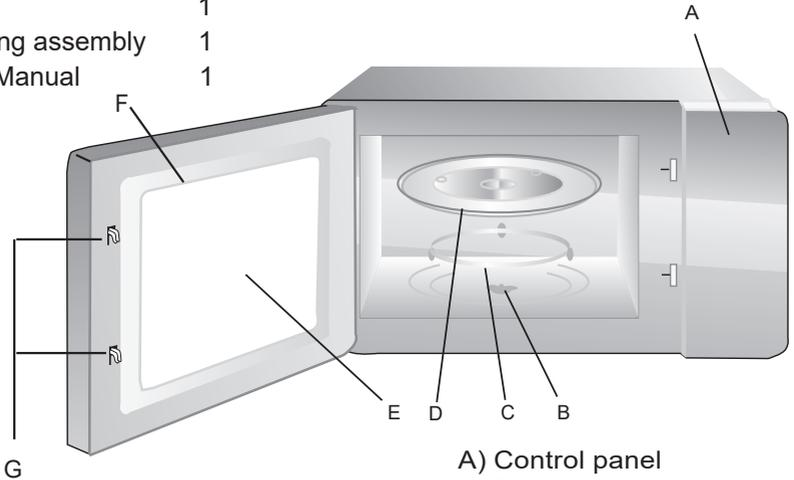

- A) Control panel
- B) Turntable shaft
- C) Turntable ring assembly
- D) Glass tray
- E) Observation window
- F) Door assembly
- G) Safety interlock system



Grill tray(Cannot be used in microwave function and must be placed on the grill rack)

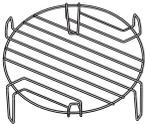

Grill Rack(Can not be used in microwave function and must be placed on the glass tray)

Turntable Installation

Hub (underside)

Glass tray

Turntable shaft

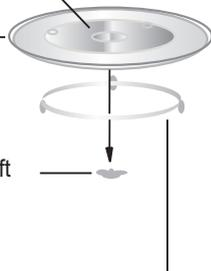

Turntable ring assembly

- a. Never place the glass tray upside down. The glass tray should never be restricted.
- b. Both glass tray and turntable ring assembly must always be used during cooking.
- c. All food and containers of food are always placed on the glass tray for cooking.
- d. If glass tray or turntable ring assembly cracks or breaks, contact your nearest authorized service center.

Countertop Installation

Remove all packing material and accessories. Examine the oven for any damage such as dents or broken door. Do not install if oven is damaged.

Cabinet: Remove any protective film found on the microwave oven cabinet surface. Do not remove the light brown Mica cover that is attached to the oven cavity to protect the magnetron.

Installation

1. Select a level surface that provide enough open space for the intake and/or outlet vents.
2. Plug your oven into a standard household outlet. Be sure the voltage and the frequency is the same as the voltage and the frequency on the rating label.

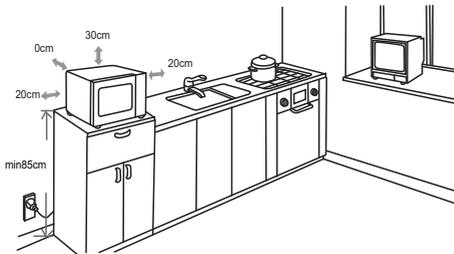

WARNING: Do not install oven over a range cooktop or other heat-producing appliance. If installed near or over a heat source, the oven could be damaged and the warranty would be void.

- (1) The minimum installation height is 85cm.
- (2) The rear surface of appliance shall be placed against a wall. Leave a minimum clearance of 30cm above the oven, a minimum clearance of 20cm is required between the oven and any adjacent walls.
- (3) Do not remove the legs from the bottom of the oven.
- (4) Blocking the intake and/ or outlet openings can damage the oven.
- (5) Place the oven as far away from radios and TV as possible. Operation of microwave oven may cause interference to your radio or TV reception.

The accessible surface may be hot during operation.



CONTROL PANEL

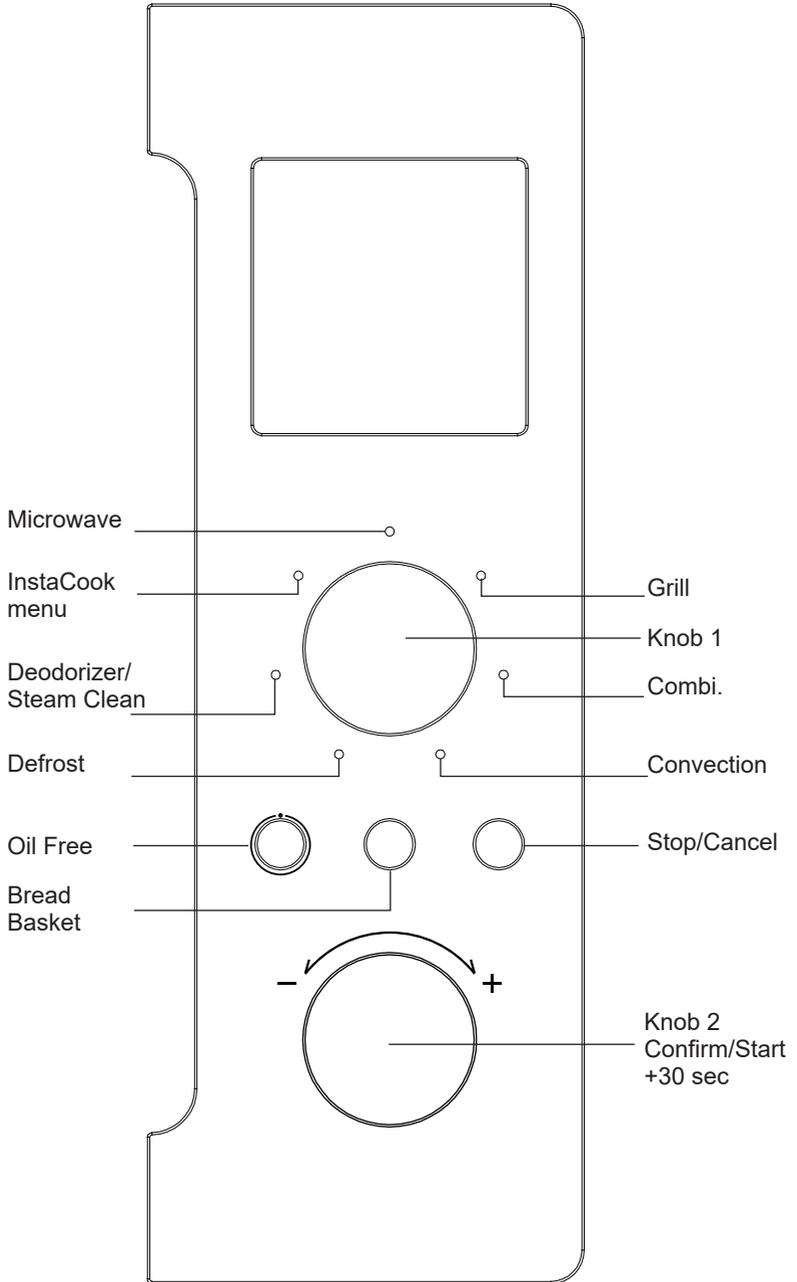

SELECTION OF BASIC FUNCTIONS

- Rotate Knob 1 to scroll options from Defrost to Convection as per the table.
- For selection of any function, press **Confirm/Start**.
- **For Example:** In order to select Microwave function, scroll the **Knob 1** till Microwave and then press **Confirm/Start** to select that particular function.

FUNCTION	DEFROST	DEODORIZER /STEAM CLEAN	INSTACOOK	MICROWAVE	GRILL	COMBINATION	CONVECTION
DISPLAY ON 7 SEGMENT	dF	dSC	InC	PHI	Gr	Cbn	Con

BASIC FUNCTIONS

MICROWAVE:

- Select Microwave option using the Knob 1. It will display “PHI” (i.e. 100% power) on the 7 - segment display.
- Change the power level of Microwave using the Knob 2 as per the table and press Confirm/Start to select the required power level.

Display	PHI	P90	P80	P70	P60	P50	P40	P30	P20	P10
Output Power	100%	90%	80%	70%	60%	50%	40%	30%	20%	10%

- After selecting the power level, it should allow user to set the time “00:00” for which the Microwave to be kept running using the **Knob 2**.
- **Confirm/Start** Button in order to Start the operation.

Grill:

- After selecting Grill option using the Knob 1, it will display “Gr” on the 7 - segment display.
- Now set the time for which the Grill function is to be kept running using the Knob 2.
- Press Confirm/Start Button in order to Start the operation.

Convection Preheat:

- Select Convection option using the Knob 1. It will display “150” on the 7 - segment display.
- Change the temperature using the Knob 2 as per the table and press Confirm/Start Button to select the temperature.
- Press Confirm/Start Button in order to Start the operation

Set Temperature	150	160	170	180	190	200	210	220
Display	150	160	170	180	190	200	210	220

Convection

- Select Convection option using the Knob 1. it will display “150” on the 7 - segment display.
- Change the temperature using the Knob 2 as per the table and press Confirm/Start to select the required temperature.
- Set the time for which the Convection to be kept running by using the Knob 2.
- Press Confirm/Start Button in order to Start the operation.

Set Temperature	150	160	170	180	190	200	210	220
Display	150	160	170	180	190	200	210	220

SELECTION OF COMBINATION MODE

- Select Combination option using the Knob 1. It will display “C-1” on the 7 - segment display.
- Scroll to select any combination modes from C-1 to C-4 using the Knob 2 as per the table and press Confirm/Start to select the required combination mode.
- Set the time by using the Knob 2.
- Press Confirm/Start Button in order to Start the operation.

Combination Mode	Display	Operation
Micro+Grill combo 1	C-1	30% Micro and 70% Grill
Micro+Grill combo 2	C-2	55% Micro and 45% Grill
Micro+Convection combo 1	C-3	Operating temp 150 degrees
Micro+Convection combo 2	C-4	Operating temp 180 degrees

Defrost:

- Select Defrost option using Knob 1. Set the time for which the Defrost function needs to be kept running using the Knob 2.
- Press Confirm/Start Button in order to Start the operation.

Deodorizer/Steam Clean:

- After Selecting Deodorizer / Steam Clean option using Knob 1, scroll between “dE” and “SC” and press Confirm/Start to select the desired function.
- If dE is selected, press Confirm/Start Button in order to start the operation. This will run the microwave fan for 5 Minutes.
- If SC is selected, press Confirm/Start Button in order to start the operation. This will run the microwave for 5 Minutes.

VALID RECIPE NUMBERS FOR EACH AUTO COOK MENU

Menu Name		No. of submenus
Oil Free	oF	1 to 47
Bread Basket	bb	1 to 22
Tadka/Curries	tC	1 to 48
India's Best	lb	1 to 74
International	ln	1 to 30
Breakfast/Snacks	bS	1 to 52
Steam Cook/Fermentation	SF	1 to 29
Paneer/Ghee/Curd	PG	1 to 4
Kitchen Assistant	AS	1 to 31
Kids Special	SP	1 to 16

HOW ACM FUNCTIONS WORK?

Oil Free

- When Oil Free option is pressed, “oF” will be displayed in the 7-segment display.
- Select the submenu number using the Knob 2 ranging from 1 to 47.
- Press Confirm/Start Button in order to Start the operation.

Bread Basket

- When Bread Basket option is pressed, “bb” will be displayed in the 7-segment display.
- Select the submenu number using the Knob 2 ranging from 1 to 22.
- Press Confirm/Start Button in order to Start the operation.

Other Instacook menus

- Select Instacook option using the Knob 1. Scroll from (Tadka/Curries) tC to (Kids special) SP using the Knob 2 as per the table and press Confirm/Start to select the required Instacook menu.
- Select a valid submenu by using the Knob 2 and press Confirm/Start

Example:

In order to select any submenu in **Oil Free**:

(For example: **CHICKEN KABABS**, the submenu number is **8**)

- After selecting **Oil Free**, select the valid submenu by rotating the **Knob 2**. In this case, it is "8".
- Pressing the **Confirm/Start** button.

INSTACOOK MENU

OIL FREE

Category	Recipe-	Ingredients:	500 gr
OF1	CHICKEN LOLLYPOPS	Chicken Wings	500 gms
		Maida	3 tbsp
		Eggs	3
		Soya Sauce	1½ tbsp
		Green Chilli Paste	2½ tsp
		Ginger, Garlic Paste	2 tsp
		Garam Masala	2 tsp
		Pepper Powder	½ tsp
		Chilli Sauce	1½ tbsp
		Red Color (Optional)	
		Salt To Taste	
<p>Method of Preparation: “Marinate the chicken with the all ingredients for 1 hour. Arrange the marinated chicken in a lightly greased crusty plate and then place the crusty plate on the mesh rack in the microwave oven. Select category OF1, enter recipe code and press start. In between, turn the chicken pieces once.”</p>			

Category	Recipe-	Ingredients:	500 gr
OF2	MUTTON KABAB	Boneless Mutton, Minced	500 gms
		Coriander Powder	2 tsp
		Khus Khus Grinded	¾ cup
		Cumin Powder	2 tsp
		Curd	¾ cup
		Garlic Paste	2 tsp
		Ginger Paste	2 tsp
		Onion Paste	¾ cup
		Salt To Taste	
<p>Method of Preparation: “Apply ginger-garlic paste, coriander- cumins powder, khus khus, beaten curds, salt, to the minced mutton and allow the mutton to marinate for about 2 hours. Make the meat into shape of kebab, arrange the mutton kababs on a lightly greased crusty plate, and place the crusty plate on the mesh rack in the microwave oven. Select category OF2, enter recipe code and press start. Serve hot.”</p>			

Category	Recipe-	Ingredients:	500 gr
OF3	CHICKEN TANDOORI	Chicken Breast Or Legs	500 gr
		Red Chilli Powder	1½ tsp
		Lemon Juice	1½ tsp
		Yogurt	1 cup
		Ginger Paste	1½ tsp
		Garlic Paste	1½ tsp
		Garam Masala Powder	1½ tsp
		Chaat Masala	1½ tsp
		Salt To Taste	

Method of Preparation: "Marinate the chicken with the all ingredients for 3 hours. Arrange the marinated chicken in a lightly greased crusty plate and place the crusty plate on the mesh rack in the microwave oven. Select category OF3, enter recipe code and press start. In between, turn the chicken once.

Category	Recipe-	Ingredients:	500 gr
OF4	LITTI	Wheat Flour	2½ cup
		Yogurt	1½ cup
		Salt To Taste	
		Filling	
		Sattu	2 cup
		Ginger, Garlic Paste	1¼ tsp
		Cloves	6
		Green Chilies Chopped	1 tsp
		Coriander Leaves Chopped	¾ cup
		Ajwain	1¼ tsp
		Onion Seeds	1¼ tsp
		Salt To Taste	
		Lemon Juice	1¼ tsp

Method of Preparation: "Add salt and yogurt to the wheat flour and knead into a soft dough. Rest the dough for some time. For the filling mix sattu with all filling ingredients. Now, Divide the dough into lemon sized balls and spread them into small puris with your fingers. Place a portion of the filling mixture and once again roll them into balls.

Arrange them on a lightly greased baking dish and place the baking dish on the mesh rack in the microwave oven. Select category OF4, enter recipe code and press start. In between, turn the balls once.

Category	Recipe-	Ingredients:	500 gr
OF5	BATI	Whole Wheat Flour (Gehun Ka Atta)	2 cup
		Semolina (Rava)	1 cup
		Besan (Bengal Gram Flour)	3 tbsp
		Milk	1½ cup
		Melted Ghee	1 cup
		Salt To Taste	

Method of Preparation: "Mix all the ingredients and knead into a firm dough and make round flatten shape batis . Arrange batis in a lightly greased crusty plate and place the crusty plate on the mesh rack in the microwave oven. Select category OF5, enter recipe code and press start. Turn once in between. Serve hot"

Category	Recipe-	Ingredients:	500 gr
OF6	CHICKEN ROAST	Chicken	500 gms
		Ground Black Pepper	2 tsp
		Lemon Juice	2 tsp
		Garlic	2 tsp
		Thyme	2 tsp
		Salt To Taste	
Method of Preparation: "Take a mixing bowl. Add oil, chicken, salt, pepper, garlic, lemon, thyme and mix well. Now, set it aside for 30 minutes to marinate. Arrange marinated chicken in a lightly greased crusty plate and place the crusty plate on the mesh rack and in the microwave oven. Select category OF6, enter recipe code and press start. Turn once in-between. Serve hot."			

Category	Recipe-	Ingredients:	500 gr
OF7	LEMON CHICKEN	Boneless Chicken Breast	500 gms
		Garlic Paste	2 tsp
		Grated Lemon Zest	1¼ tsp
		Lemon Juice	2 tbsp
		Dried Oregano	1¼ tsp
		Thyme Leaves	Few
		Salt And Pepper To Taste	
Method of Preparation: First, marinate the chicken with the all ingredients for 1 hour. Arrange the marinated chicken in a lightly greased baking dish and place the baking dish on the mesh rack in the microwave oven. Select category OF7, enter recipe code, and press start. Turn once in-between. Serve hot.			

Category	Recipe-	Ingredients:	500 gr
OF8	CHICKEN KABABS	Boneless Chicken (Cut Into 1½" Pieces)	500 gms
		For Marinade	
		Onion Paste	1 cup
		Garlic, Ginger Paste	2 tbsp
		Cumin Powder	1 tsp
		Red Chilli Flakes	1 tsp
		Black Pepper (Freshly Crushed)	1 tsp
		Barbeque Sauce	2 tsp
		Oregano	1 tsp
		Thyme	2 tsp
		Salt To Taste	
Method of Preparation: "Take a mixing bowl. Mix all the ingredients and then add the chicken. Mix well & set it aside for 1 hour. Keep the marinated chicken on lightly greased crusty plate and place the crusty plate on the mesh rack in the microwave oven. Select category OF8, enter recipe code and press start. Turn once in between. Serve hot."			

Category	Recipe-	Ingredients:	500 gr
OF9	RESHMI KABAB	Boneless Chicken	500 gms
		Garlic Paste	2 tsp
		Ginger Paste	2 tsp
		Coriander Leaves Paste	2 tbsp
		Onions Paste	2 tsp
		Yoghurt	2 cup
		Almonds Grated	2 tbsp
		Juice Of Lemon	1
		Salt To Taste	
<p>Method of Preparation: "Marinate the chicken with the all ingredients for 2 hour. Arrange the marinated chicken in a lightly greased baking dish and place the baking dish on the mesh rack in the microwave oven. Select category OF9, enter recipe code and press start. Turn once in-between. Serve hot."</p>			

Category	Recipe-	Ingredients:	500 gr
OF10	KASTOORI KABAB	Boneless Chicken Mince (Keema)	500 gms
		For Marinade	
		Bread Crumbs	1½ cup
		Roasted Besan	3 tbsp
		Chopped Coriander Leaves	4 tbsp
		Red Chillli Powder	2 tsp
		Jeera Powder	1 tsp
		Pepper Powder n	1 tsp
		Ginger Garlic Paste	2 tsp
		Elaichi Powder	1 tsp
		Kesar (Soaked In ½ Cup In Milk)	1 tsp
		Lemon Juice	2 tsp
		Chaat Masala For Garnish	1 tsp
		Salt To Taste	
<p>Method of Preparation: "Marinate the mince with all the ingredients mentioned under marinade. Make flat kababs of the mixture.Keep the kababs on lightly greased crusty plate, place the crusty plate on the mesh rack in the microwave oven. Select category OF10,enter recipe code & press start. Turn once in between. Sprinkle chaat masala & serve."</p>			

Category	Recipe-	Ingredients:	500 gr
OF11	BAKED CHICKEN	Chicken	500 gms
		Tomato Sauce	1 cup
		Butter	3 tbsp
		Bread-Crumbs	1½ cup
<p>Method of Preparation: In a mixing bowl add butter, chicken, tomato sauce, salt, mix well and toss the chicken in the bread crumbs and arrange chicken pieces in a lightly greased crusty plate. Place the crusty plate on the mesh rack in the microwave oven. Select category OF11, enter recipe code & press start.Serve hot.</p>			

Category	Recipe-	Ingredients:	500 gr
OF12	CHICKEN 65	Chicken Breast - Boneless	500 gms
		Red Chilli Powder	1½ tsp
		Pepper Powder	1½ tsp
		Egg Whites	3
		Corn Flour	1 tbsp
		Wheat Flour	1 tbsp
		Butter Milk	1 cup
		Ginger Paste	1½ tsp
		Garlic Paste	1 tsp
		Orange Food Color	1 tsp
		Lemon Juice	1½ tsp
		Salt To Taste	

Method of Preparation: Marinate the chicken with the all ingredients for 2 hours. Arrange the marinated chicken in a lightly greased crusty plate and place the crusty plate on the mesh rack in the microwave oven. Select category OF12, enter recipe code and press start . Turn once in between. Serve hot.

Category	Recipe-	Ingredients:	300 gr
OF13	BAKED FISH	Fish	300 gms
		Butter	2 tbsp
		Sour Cream	2 tbsp
		Bread Crumbs	1½ cup
		Grated Cheese	1 tbsp
		Parsley (For Garnish)	
		Salt To Taste	

Method of Preparation: Marinate fish with butter and sour cream for 30 minutes. Toss the marinated fish in bread crumbs and arrange it in a lightly greased baking dish, sprinkle the grated cheese over it and place the baking dish on the mesh rack in the microwave oven. Select category OF13, enter recipe code, and press start. Turn once in-between. Garnish with parsley.Serve hot.

Category	Recipe-	Ingredients:	300 gr
OF14	CHICKEN NUGGETS	All-Purpose Flour	¾ cup
		Garlic Paste	1½ tsp
		Ground Black Pepper	¾ tsp
		Chicken Breasts, Cut Into 1½-Inch Pieces	300 gr
		Breadcrumbs	1½ cup
		Egg	2
		Salt To Taste	

Method of Preparation: "Take flour, garlic, pepper, salt and chicken. Mix them well. Dip the chicken in the beaten egg , then in the breadcrumbs. Arrange them on a lightly greased baking dish and place the baking dish on the mesh rack in the microwave oven. Select category OF14, enter recipe code and press start. Turn once in -between. Serve hot."

Category	Recipe-	Ingredients:	300 gr
OF15	FISH AMRITSARI	Boneless Fish (Cut Into 2" Pieces)	300 gr
		Lemon Juice	1½ tsp
		Salt	½ tsp
		For Batter	
		Egg (Beaten)	2
		Besan	2½ tbsp
		Curd	2½ tbsp
		Ajwain	1½ tsp
		Ginger-Garlic Paste	1 tbsp
		Lemon Juice	1½ no
		Salt, Red Chilli Powder, Garam Masala,	As per taste
		Chaat Masala, Turmeric Powder	As per taste
		Bread Crumbs (For Coating)	1½ cup
<p>Method of Preparation: Apply lemon juice, salt to fish pieces and set aside for 10 minutes. Apply oil to the fish pieces. Make batter with all ingredients other than bread crumbs. Rub the batter on the fish pieces and toss it in bread crumbs. Set it aside for 1 hour for marinate. Arrange the fish in a lightly greased crusty plate and place the crusty plate on the mesh rack in the microwave oven. Select category OF15, enter recipe code, press start. Serve hot.</p>			

Category	Recipe-	Ingredients:	300 gr
OF16	MATAR KABAB	Boiled Peas	300 gr
		Roasted Makhanas	1½ cup
		Chopped Green Chillies	1½ tsp
		Garam Masala	1½ tsp
		Seeds Of Elaichi	Few
		Cashewnuts	3 tbsp
		Pepper Powder	¾ tsp
		Chaat Masala For Garnish	¾ tsp
		Salt To Taste	
<p>Method of Preparation: Grind the boiled peas, green chillies & elaichi seeds together to form a fine paste. Grind the makhanas & cashew-nuts together into a rough powder. Mix peas & makhanas paste. Add salt, pepper and garam masala. Make small balls & flatten them to get small round kababs. Keep the kababs on lightly greased crusty plate, place the crusty plate, on the mesh rack in the microwave oven. Select category OF16, enter recipe code & press start. Sprinkle chaat masala & serve.</p>			

Category	Recipe-	Ingredients:	300 gr
OF17	CORN KABAB	Boiled Potatoes	300 gr
		Boiled Sweet Corns	¾ cup
		Onions (Chopped)	¾ cup
		Green Chillies (Chopped)	1½ tsp
		Coriander (Chopped)	3 tbsp
		Pudina (Chopped)	3 tbsp
		Melted Butter	3 tbsp
		Garam Masala	1½ tsp
		Lemon Juice	1½ tsp
		Bread Crumbs	1 cup
		Pepper Powder	¾ tsp
		Salt To Taste	
<p>Method of Preparation: Mash the boiled potatoes & corns. Mix them well. Now add onions, green chillies, coriander pudina, garam masala, melted butter, salt & pepper. Add bread crumbs& lemon juice. Make long kababs out of this mixture. Keep the kababs on lightly greased crusty plate. Place the crusty plate on the mesh rack in the microwave oven. Select category OF17, enter recipe code and press start. Turn once in-between. Serve with chutney or sauce. Serve hot.</p>			

Category	Recipe-	Ingredients:	300 gr
OF18	CHEESE CORN BALLS	Boiled Sweet Corn Kernels,	2 cup
		Cheese Grated	½ cup
		Potatoes, Boiled And Mashed	½ cup
		Capsicum,	½ cup
		Breadcrumbs	1½ cup
		Maida	1 tbsp
		Corn Flour,	1 tbsp
		Oregano,	Few
		Salt To Taste	
<p>Method of Preparation: Blend all ingredients together. Roll them to make corn balls. Arrange corn balls in a crusty plate and place the crusty plate on the mesh rack in the microwave oven. Select category OF18, enter recipe code and press start. Turn once in-between. Serve hot.</p>			

Category	Recipe-	Ingredients:	300 gr
OF19	PANEER PAKORA	Paneer (Cut Into 1.5" Cubes)	300 gr
		For Batter	
		Besan	1½ cup
		Turmeric Powder	¼ tsp
		Red Chilli Powder	1½ tsp
		Garam Masala	1½ tsp
		Salt To Taste,	
		Water As Required	
<p>Method of Preparation: In a bowl, take all the batter ingredients, mix well and make a smooth paste of it. Place all the paneer pieces even-ly coated with the batter, on the tawa. Keep the tawa on the high rack & pour oil on all pakoras. Select category OF19, enter recipe code & press start. Turn the pakoras once in between. Serve hot with Chutney or Sauce.</p>			

Category	Recipe-	Ingredients:	300 gr
OF20	HARA BARA KABAB	Spinach, Finely Chopped	¾ cup
		Green Peas Boiled And Mashed	¾ cup
		Potatoes Boiled, Peeled And Grated	1 cup
		Green Chillies Chopped	1½ tsp
		Ginger Chopped	1½ tsp
		Coriander Leaves Chopped	2½ tbsp
		Chaat Masala	1½ tsp
		Corn flour	2½ tbsp
		Salt To Taste	
<p>Method of Preparation: In a bowl take all the ingredients other than oil. Mix well and make flat tikkies of it. Arrange all the tikkies in a lightly greased crusty plate. Apply oil and place the crusty plate on the mesh rack in the microwave oven. Select category OF20, enter recipe code & press start. Serve hot with Sauce.</p>			

Category	Recipe-	Ingredients:	300 gr
OF21	SABUDANA VADA	Boiled Potato	2 nos.
		Sabudana (Soaked)	¾ cup
		Roasted & Crushed Peanuts	2 tbsp
		Chopped Green Chilli	2 nos.
		Finely Chopped Ginger	½ tsp
		Fresh Curry Leaves	Few
		Coriander Leaves (Chopped)	1 tbsp
		Salt to taste	
<p>Method of Preparation: In a bowl take all ingredients other than oil. Mix well and make flat tikkies of it. Arrange all the tikkies in a lightly greased crusty plate, apply oil and place the crusty plate on the mesh rack in the microwave oven. Select category OF21, enter recipe code & press start. Serve hot with Sauce.</p>			

Category	Recipe-	Ingredients:	300 gr
OF22	CHANA KABABS	Kabuli Chana (Chole), Boiled	300 gr
		Soaked Bread Pieces	2
		Bread Crumbs (For Coating)	1 cup
		Red Chilly	1½ tsp
		Garlic ,Ginger Paste	1½ tsp
		Cloves	¼ tsp
		Pepper Powder	¾ tsp
		Cinnamon Powder	¾ tsp
		Salt To Taste	
<p>Method of Preparation: Grind boiled kabuli chana, cloves, pepper powder, cinnamon powders, garlic cloves, salt, ginger, soaked bread pieces and whole red chilli to form a paste. Now shape the paste in the form of kababs & roll out each kababs in bread crumbs for complete coating. Keep the kababs on tawa & keep the tawa on high rack. Select category OF22, enter recipe code & press start. Turn once in between. Serve hot.</p>			

Category	Recipe-	Ingredients:	300 gr
OF23	FISH TANDOORI	Pomfret	300 gr
		For Marinade	
		Red Chili Powder	1½ tsp
		Garlic ,Ginger Paste	1½ tsp
		Jeera	¾ tsp
		Garam Masala	1½ tsp
		Tandoori Masala	1½ tsp
		Dhania Powder	¾ tsp
		Amchoor Powder	¾ tsp
		Chaat Masala	¾ tsp
		Lemon Juice	1½ tsp
		Salt To Taste	
Method of Preparation: Marinade fish with all marinade ingredients for 2 hours. Arrange the marinated fish in a lightly greased baking dish.Place the baking dish on the mesh rack in the microwave oven. Select category OF23, enter recipe code and press start.Serve hot.			

Category	Recipe-	Ingredients:	300 gr
OF24	BHARWAN TAMATAR	Tomato (Hollowed)	300 gr
		For Stuffing	
		Onion Chopped	1 cup
		Paneer (Mashed)	1 cup
		Garam Masala,	1½ tsp
		Red Chilli Powder,	1½ tsp
		Cumin Powder	¾ tsp
		Coriander Leaves Chopped	2½ tbsps
Method of Preparation: Take microwave oven safe bowl, add add all ingredients hollowed tomatoes with all stuffing ingredients. Grease the tomatoes with few drops of oil. Arrange the stuffed tomatoes in a lightly greased baking dish, place the baking dish on the mesh rack in the microwave oven. Select category OF24, enter recipe code & press start. Serve hot.			

Category	Recipe-	Ingredients:	300 gr
OF25	GRILLED PRAWNS	Prawns	300 gr
		Onion Paste	1½ cup
		Ginger, Garlic Paste	2 tsp
		Red Chilli Powder	1½ tsp
		Pepper Powder	½ tsp
		Salt To Taste	
Method of Preparation: Marinate the prawns with the all ingredients for 30 minutes. Arrange the marinate prawns in a lightly greased crusty plate and place the crusty plate on the mesh rack in the microwave oven. Select category OF25, enter recipe code and press start. Turn once in-between. Serve hot.			

Category	Recipe-	Ingredients:	300 gr
OF26	FISH ROAST	Pomfret - Washed And Cleaned	300 gr
		Garlic Paste	1½ tsp
		Lemon Juice	1 tsp
		Chilli Powder	1½ tsp
		Turmeric Powder	½ tsp
		Pepper Powder	¼ tsp
		Garam Masala	1½ tsp
		Rice Flour	2 tbsp
		Salt To Taste	
<p>Method of Preparation: Mix all the ingredients to make a paste. Toss the fish into it and apply evenly on all sides. Set aside for 1 hr. Arrange the marinated fish in a lightly greased crusty plate and place the crusty plate on the mesh rack in the microwave oven. Select category OF26, enter recipe code and press start. Turn once in-between. Remove and serve.</p>			

Category	Recipe-	Ingredients:	300 gr
OF27	VEGETABLE CUTLETS	Potatoes boiled	1½ cup
		Green Peas boiled	½ cup
		Beans boiled	½ cup
		Beetroot boiled	½ cup
		Corn flour	½ cup
		Dry Mango Powder	1½ tsp
		Red chilli powder	1½ tsp
		Salt to taste	
		Coriander leaves for garnish	
<p>Method of Preparation: Blend all boiled ingredients together. Mash them lightly. Add all remaining ingredients, mix well in the shape of medium sized cutlets. Arrange cutlets in a lightly greased crusty plate. Place the crusty plate on the mesh rack in the microwave oven. Select category OF27, enter recipe code and press start. Turn once in-between. Serve hot.</p>			

Category	Recipe-	Ingredients:	300 gr
OF28	ALOO TIKKI	Boiled Aloo	300 gms
		Green Peas Cooked	1½ cup
		Black Pepper Powder	¾ tsp
		Ginger Paste	1½ tsp
		Garam Masala	1½ tsp
		Red Chili Powder	1½ tsp
		Cumins Powder	1½ tsp
		Salt to taste	
<p>Method of Preparation: Mash potatoes and green peas together. Add all the remaining ingredients, mix well and shape them as medium sized tikkis. Arrange tikki in a lightly greased crusty plate and place the crusty plate on the mesh rack in the microwave oven. Select category OF28, enter recipe code and press start. Turn once in-between. Serve hot.</p>			

Category	Recipe-	Ingredients:	300 gr
OF29	CHICKEN SAUSAGES	Ready To Cook Chicken Sausages	
Method of Preparation: Arrange chicken sausages in a lightly greased crusty plate, place the crusty plate on the mesh rack in the micro-wave oven. Select category OF29, enter recipe code and press start. Turn once in-between.			

Category	Recipe-	Ingredients:	300 gr
OF30	FRENCH FRIES	Slice Potatoes In To French Fries	300 gr
		Sea Salt As Required	
		Cold water As Needed	
Method of Preparation: Take water in a mixing bowl, add potatoes into it, set it aside for 1 hr. Drain off the water, and dry them with paper towel. Arrange the french fries in a lightly greased crusty plate and place the crusty plate on the mesh rack in the microwave oven. Select category OF30, enter recipe code and press start. Turn once in-between. Remove and mix with salt. Serve hot.			

Category	Recipe-	Ingredients:	300 gr
OF31	FISH CUTLETS	Fish boiled & bones removed	300 gr
		Egg	2
		Bread slices soaked in water	3
		Garlic paste	½ tsp
		Ginger paste	½ tsp
		Bread Crumbs	1½ tbsp
		Green Chilies	3
		Corn Flour	1½ tbsp
		Garam Masala	1½ tsp
		Turmeric Powder	½ tsp
		Coriander Leaves	1½ tbsp
		Salt to taste	
Method of Preparation: Mash the fish and bread slices gently with the hands and adds all ingredients together other than eggs, bread crumbs and mash them lightly. Add all remaining ingredients, mix well and shape them as medium sized cutlets. Arrange cutlets in a lightly greased crusty plate. Place the crusty plate on the mesh rack in the microwave oven. Select category OF31, enter recipe code and press start. Turn once in-between. Serve hot.			

Category	Recipe-	Ingredients:	300 gr
OF32	SURAN CUTLETS	Suran (Cooked)	300 gr
		Lime Juice	2 tsp
		Chopped Ginger	1 tsp
		Chopped Green Chilies	Few
		Curry Leaves Chopped	Few
		Chopped Coriander Leaves	3 tbsp
		Rice Flour	3 tbsp
		Rice Flour For Coating	3 tbsp
		Black Pepper	½ tsp
		Cumin Seeds	1 tsp
		Fennel Seeds	Few
		Fenugreek Seeds	Few
		Cloves	3
		Salt As Required	
Method of Preparation: Mash the suran gently with the hands and adds all ingredients together, mash them lightly, mix well and shape as medium sized cutlets. Coat with rice flour. Arrange all the cutlets in a lightly greased crusty plate and place the crusty plate on the mesh rack in the microwave oven. Select category OF32, enter recipe code and press start. Turn once in-between. Serve hot.			

Category	Recipe-	Ingredients:	300 gr
OF33	TANDOORI ALOO	Aloo (Cut Into Quarters)	300 gr
		For Marinade	
		Curd	2½ tbsp
		Garlic Paste	1½ tsp
		Cumin Powder	¾ tsp
		Red Chilli Powder	1½ tsp
		Tandoori Masala	1½ tsp
		Tandoori Color	a pinch
		Salt To Taste ,	
		Chaat Masala For Garnish	
		Lime Juice For Garnish	
Method of Preparation: "Take a mixing bowl. Add all the ingredients of marinade and add the aloo pieces, mix well & set aside for ½ hour for marinate. Keep the marinated aloo on lightly greased baking dish and place the baking dish on the mesh rack in the microwave oven. Select category OF33, enter recipe code & press start. Sprinkle chaat masala, lemon juice & serve."			

Category	Recipe-	Ingredients:	300 gr
OF34	TANDOORI GOBHI	Cauliflower Florets	300 gr
		For Marinade	
		Curd	2½ tbsp
		Red Chilli Powder	1½ tsp
		Jeera Powder	¾ tsp
		Coriander Powder	¾ tsp
		Garam Masala	1½ tsp
		Tandoori Color Or Haldi	a pinch
		Salt To Taste	
<p>Method of Preparation: "Take a mixing bowl, Add all the ingredients of marinade, cauliflower florets and mix well. Set it aside for 1 hour to marinate. Keep the marinated cauliflower florets on lightly greased baking dish. Place the baking dish on the mesh rack in the microwave oven. Select category OF34, enter recipe code & press start. Serve hot."</p>			

Category	Recipe-	Ingredients:	300 gr
OF35	TANDOORI MUSHROOM	mushroom buttons (stalk removed)	300 gr
		For Marinade	
		Curd	2½ tbsp
		ginger, garlic Paste	¾ tsp
		coriander powder	¾ tsp
		cumin powder	¾ tsp
		amchoor powder	1 tsp
		Cornflour	2½ tbsp
		tandoori color	A pinch of
		salt to taste	
<p>Method of Preparation: "Take a mixing bowl, add all the ingredients of marinade and add the mushroom buttons. Mix well & set it aside 1 hour for marinate. Keep the marinated mushroom buttons on lightly greased baking dish and place the baking dish on the mesh rack in the microwave oven. Select category OF35, enter recipe code & press start. Serve hot."</p>			

Category	Recipe-	Ingredients:	300 gr
OF36	MIX VEG PLATTER	Paneer (Cut 1½" Cubes)	¼ cup
		Mushroom Buttons (Trim The Stalk)	¼ cup
		Baby Corn (Blanched)	¼ cup
		Capsicum (Cut Into Large Cubes)	¼ cup
		Tomatoes (Cut Into Quarters)	¼ cup
		Onion (Cut Into Quarters & Separated)	¼ cup
		For Marinade	
		Curd	2½ tbsp
		Thick Cream	2½ tbsp
		Cornflour	2½ tbsp
		Red Chilli Powder	1½ tsp
		Ginger Garlic Paste	1½ tsp
		Tandoori Masala	1½ tsp
		Tandoori Color	a pinch
		Salt To Taste	
<p>Method of Preparation: "Take a mixing bowl, add all the ingredients of marinade and add the paneer, mushroom buttons, baby corn, capsicum, tomatoes, onion. Mix them well & set aside for ½ hour for marinate. Keep the marinated vegetables on lightly greased baking dish, place the baking dish on the mesh rack in the microwave oven. Select category OF36, enter recipe code and press start. Serve hot."</p>			

Category	Recipe-	Ingredients:	300 gr
OF37	SAMOSA	All-purpose flour	1 cup
		Ajwain	a pinch of
		Salt as required	
		Water as required	
		For Filling:	
		Boiled Potatoes	2
		Boiled Pies	¼ cup
		Grated Ginger	¼ tsp
		Red Chilli Powder	1 tsp
		Coriander Powder	½ tsp
		Cumins Powder	
		Kasoori Methi	
		Lemon Juice	
		Garam Masala	
		Chopped Coriander Leaves	
		Salt to taste	
<p>Method of Preparation: Mix the maida with salt, oil, ghee and ajwain, combine to form a crumbly mixture. Now slowly add enough water to make pliable dough, not too soft. Divide the dough and shape into balls. Now prepare the filling for the samosa by mixing all the ingredients for filling. Divide the dough into 4 equal parts and make into balls. Roll each ball into 6-inch diameter circles and cut each circle in half. Spread the paste lightly all along the edge of one semicircle. Spread potato filling in center leaving the edges fold it into triangle shape pockets or desired shape seal the edges with a little water. Continue filling the rest of the Samosa's. Step 1:- Now Keep the 4 Samosa on the crusty plate and brush all sides with oil. Put the crusty plate on grill high rack and select category OF37, enter recipe code, press start. Step 2:- When beep, turn the side and press start. Serve hot.</p>			

Category	Recipe-	Ingredients:	
OF38	PANEER CUTLET	Grated Paneer	250 g
		Boiled Potato	2
		Bread Crumbs	1 cup
		Ginger, Garlic Paste	1 tsp
		Red Chili Powder	1 tsp
		Turmeric Powder	¼ tsp
		Garam Masala	1 tsp
		Coriander Leaves	2 tbsp
		Salt to taste	

Method of Preparation: Mix the maida with salt, oil, ghee and ajwain, combine to form a crumbly mixture. Now slowly add enough water to make pliable dough, not too soft. Divide the dough and shape into balls. Now prepare the filing for the samosa by mixing all the ingredients for filling. Divide the dough into 4 equal parts and make into balls. Roll each ball into 6-inch diameter circles and cut each circle in half. Spread the paste lightly all along the edge of one semicircle. Spread potato filling in center leaving the edges fold it into triangle shape pockets or desired shape seal the edges with a little water. Continue filling the rest of the Samosa's. Step 1:- Now Keep the 4 Samosa on the crusty plate and brush all sides with oil. Put the crusty plate on grill high rack and select category OF38, enter recipe code and press start. Step 2:- When beep, turn the side and press start. Serve hot.

Category	Recipe-	Ingredients:	
OF39	BENGALI DOI ILISH	Hilsa Fish chunks(Ilish Mach)	250 g
		Green Chili	4
		Smooth Curd	200 g
		Turmeric Powder	1 tsp
		Sugar	1 tbsp
		Salt to taste	

Method of Preparation: Rub fish chunks with oil, turmeric powder and salt and leave fish chunks for 15 minutes. Take a microwave oven safe bowl, add curd, sugar, green chili, mix well, place hilsa chunks in the curd mixture and coat from both sides. Cover the bowl with lid and marinade it for 30 minutes. After marinade, arrange the fish pieces in a baking or crusty plate. Place the baking dish or crusty plate on the grill mesh rack in the oven. Step 1:- Select category OF39, enter recipe code and press start. Step 2:- After beep, remove and turn the fish pieces and press start. Serve hot.

Category	Recipe-	Ingredients:	
OF40	FISH IN BANANA LEAFS	Fish Chunks	250 g
		Grated Coconut	4 tbsp
		Cumin seeds	1 tsp
		Green Chili	4
		Coriander leaves	1 cup
		Garlic, Ginger Paste	1 tsp
		Lemon Juice	3 tbsp
		Salt to taste	
		Banana Leaves	

Method of Preparation: Take a large bowl and mix together fish chunks, lemon juice and salt. Leave aside for 15 minutes. In a grinder, mix all remaining ingredients and make a fine paste. Spread banana leaf and lay the marinated fish on it. Now spread the paste over it. Fold the banana leaves neatly and arrange the banana leaves in a baking dish or crusty plate. Place the baking or crusty plate on the grill mesh rack in the oven.
1. Select category OF40, enter recipe code and press start. Step 2:- After beep, remove and turn the banana leaves upside down and press start. Serve hot.

Category	Recipe-	Ingredients:	
OF41	BHAPA ILISH	Hilsa Fish Chunks	250 g
		Grated Coconut	2 tbsp
		Mustard Seeds	2 tsp
		Green Chili	3
		Curd	2 tbsp
		Garlic, Ginger	1 tsp
		Turmeric Powder	1 tsp
		Red chili powder	½ tsp
		Poppy seeds	1½ tbsp
		Mustard Oil	2 tbsp
		Salt to taste	

Method of Preparation: Take a large bowl and mix together fish chunks, turmeric powder, red chili powder and oil. Set aside for 15 minutes. In a grinder, mix all remaining ingredients other than curd and make a fine paste. Spread the paste and curd over the fish chunks. Leave aside for 20 minutes. Arrange the fish chunks in a baking dish or crusty plate. Place the baking or crusty plate on the grill mesh rack in the oven.
1. Select category OF41, enter recipe code and press start. Step 2:- After beep, remove and turn the banana leaves upside down and press start. Serve hot.

Category	Recipe-	Ingredients:	
OF42	POTATOES AU GRATIN	Sliced Potatoes	250 g
		Sliced Onion	1
		All Purpose Flour	3 tbsp
		Milk	1 cup
		Butter	2 tbsp
		Grated Cheese	½ cup
		Pepper to taste	
		Salt to taste	
<p>Method of Preparation: In a large bowl, melt butter, stir in flour, salt and pepper until smooth. Gradually add milk. Bring to a boil; cook and stir 2 minutes or until thickened. Stir in cheese until melted. Remove; add potatoes and onion in to it. Transfer to a greased baking dish. Place the baking dish on low grill mesh rack in oven. Step 1:- Select category OF42, enter recipe code and press start. Serve hot.</p>			

Category	Recipe-	Ingredients:	
OF43	BATATA VADA	Boiled & Mashed Potatoes	250 g
		Red chili powder	1 tsp
		All Purpose Flour	1 cup
		Green Chilies	1 tsp
		turmeric powder	¼ tsp
		Garam masala powder	1 tsp
		Coriander leaves	½ cup
		Salt to taste	
<p>Method of Preparation: In a bowl add chili powder, garam masala, coriander, green chilies, salt to the mashed potatoes, mix well and take a cup of gram flour; add turmeric powder and chili powder to it. Add little water and mixing with hand make a batter (neither too thick nor too loses). Make small balls of potato mixture and flatten them to make turnovers. Brush little oil on the crusty plate. Dip each ball in the batter, keep it on the crusty plate, and brush it with oil. Step 1:- Put the crusty plate on High rack and Select category OF43, enter recipe code and press start. Step 2:- When beep, turn the side and press start. Serve aloo bonda hot with chutney.</p>			

Category	Recipe-	Ingredients:	
OF44	GUJIYA	Maida	1 cup
		Ghee	2 tbsp
		Water as required	
		For Stuffing:-	
		Desiccated Coconut	1 cup
		Grated Khoya	1 cup
		Powdered Sugar	1 cup
		Elaichi Powder	½ tsp
		Almonds Chopped	Few
		Cashew Chopped	Few
		Kishmish	Few
<p>Method of Preparation: In a bowl put maida, ghee, add water and knead a soft dough for gujiya. Keep the dough covered for 15 minutes and knead again. Divide the dough in small balls of equal size. Roll out each ball in to a thin circle. Place the rolled out circle in a gujiya mould and fill the center with stuffing. Close the gujiya mould carefully & press firmly at edges to seal them properly. Remove the excess part of the dough bulging out of the mould. Remove gujiya from mould. Prepare all the gujias in the same way. Step 1:- Arrange all gujias in on crusty plate and place it on grill mesh rack in the oven. Select category OF44,enter recipe code and start. Step 2:- After beep, remove and turn gujias upside to down carefully and press start. Serve hot.</p>			

Category	Recipe-	Ingredients:	
OF45	KHEEMA BALLS	Boiled Chicken Kheema	250g
		Boiled & Mashed Potato	2 cups
		Bengali Gram powder	2 tbsp
		Ginger, Garlic paste	1½ tsp
		Garam Masala	1 tsp
		Coriander powder	1 tsp
		Lemon juice	1½ tsp
		Salt to Taste	
<p>Method of Preparation: In a mixing bowl, mix all the ingredients together. Make balls from it. Arrange the balls in greased crusty plate or baking dish. Place the crusty plate on grill mesh rack in the oven. Step 1:- Select category OF45, enter recipe code and Press start. Step 2:- After beep, remove and turn upside to down. Press start. Serve hot.</p>			

Category	Recipe-	Ingredients:	
OF46	TANDOORI SOYA CHAAP	Soya Chaap	6 sticks
		Ginger, Garlic Paste	1 tsp
		Red Chili Powder	1 tsp
		Turmeric Powder	¼ tsp
		Garam Masala	1 tsp
		Chaat Masala	½ tsp
		Coriander powder	1 tsp
		Black Pepper Powder	½ tsp
		Curd	½ cup
		Cheese Grated	1 cube
		Salt as required	

Method of Preparation: Mix all ingredients to soya chaap sticks and marinade for 20 minutes. Arrange marinade soya chaap sticks in crusty plate. Place the crusty plate on the grill mesh rack in the oven. Step 1:- Select category OF46, enter recipe code and press start.
Step 2:- After beep, remove and turn upside to down and press start. Serve hot.

Category	Recipe-	Ingredients:	
OF47	DOSA	Dosa Batter	200 g

Method of Preparation: Take a empty crispy plate and keep it on the grill mesh rack. Place the mesh rack with crispy plate in on the oven.
Step 1:- Select category OF 47, enter recipe code and press start.
Step 2:- when beep, remove the crispy plate and pour two ladleful of dosa batter in the center of crispy plate. Spread the batter in to circular motion. Make sure that it is not too thick or not too thin. Drizzle the oil on and around. Place the crispy plate again on the mesh rack, Press start. Serve hot with sambaar & chutney.

BREAD BASKET

Category	Recipe-	Ingredients:
BB1	MILK BREAD	All Purpose Flour (Maida)
		Dry Yeast
		Sugar
		Oil
		Salt
		Milk Powder
		Water
<p>Method of Preparation: "Take warm water in a bowl, add dry yeast, sugar, mix well and cover with lid, set it aside another mixing bowl, add maida, oil, salt, milk powder and dry yeast water, mix well to make a smooth, soft dough. Punch the dough for 10 minutes. Set it aside for 15 minutes. Punch the dough again for 7 minutes. Set the dough batter in a bread tin and cover with lid, set it aside again for 20 minutes.</p> <p>Step 1: To preheat the oven, select category BB1, enter recipe code & press start</p> <p>Step 2: When your oven beeps, arrange bread tin in on the turntable and press start.Cut and serve.</p>		

Category	Recipe-	Ingredients:	1 (230 gms)
BB2	GARLIC BREAD	Warm Milk	¼ cup
		Dry Yeast	1 tsp
		Sugar	1 tsp
		Salt	pinch of
		Garlic, Finely Chopped	3 cloves
		Oregano	¼ tsp
		Unsalted Butter, Melted	1 tbsp
		Maida	1 cup
		Oil	2 tsp
		For Garlic Butter:	
		Butter, Melted	¼ cup
		Garlic, Finely Chopped	3 cloves
		Coriander Leaves, Finely Chopped	2 tbsp
		Other Ingredients:	
		Maida To Dust	3 tbsp
		Grated Cheese	¼ cup
		Chili Flakes	2 tsp
		Oregano	1 tsp
		Mixed Herbs	1 tsp
<p>Method of Preparation: "Take warm milk in a bowl. Add dry yeast, sugar, mix well and cover with a lid. Set it aside for 5 minutes. Add salt, butter, garlic, oregano and maida. Mix well to make a smooth and soft dough. Add oil and punch the dough for 5 minutes. Set it aside for 15 minutes. Punch again the dough for 5 minutes. Set the dough batter in a bowl and cover with lid. Set it aside again for 1 hour. Mix batter, garlic, coriander leaves in a bowl and spread it over the dough. Further, top it with cheese on half of the dough. Season with chili flakes, oregano, and fold the dough. Seal the edges. Brush and top with the prepared garlic butter, chili flakes and mixed herbs. Make marks over bread without cutting them fully and place it on lightly greased baking dish.</p> <p>Step 1: For preheat the oven select category BB2, enter recipe code & press start.</p> <p>Step 2: When you hear a beep, arrange baking dish in on the turntable and press start. Cut and serve.</p>			

Category	Recipe-	Ingredients:	230 gms
BB3	WHEAT BREAD	Warm Water	1¼ cups
		Active Dry Yeast	½ tbsp
		Salt	1 tsp
		Sugar	1 tbsp
		Butter, Melted	2 tbsp
		Curd	2 tbsp
		Whole Wheat Flour	3 cups
		Milk For Brushing	2 tbsp
<p>Method of Preparation: "Take warm water in a bowl, add dry yeast, sugar, mix well and cover with lid. Set it aside for 5 minutes. Take another mixing bowl. Add wheat flour, salt, butter, dry yeast and curd. Mix well to make a smooth and soft dough. Punch the dough for 10 minutes. Set it aside for 15 minutes. Punch again the dough for 5 minutes. Set the dough batter in a bread tin and cover with lid, set it aside again for 20 minutes.</p> <p>Step 1: To preheat the oven, select category BB3, enter recipe code & press start.</p> <p>Step 2: When your oven beeps, arrange bread tin in on the turntable and press start. Cut and serve.</p>			

Category	Recipe-	Ingredients:	230 gms
BB4	TOOTY FROOTY BREAD	All-Purpose Flour	2 cups
		Custard Powder	2 tbsp
		Sugar	2 tsp
		Milk Powder	2 tbsp
		Dry Yeast	1½ tsp
		Tutti Frutti	½ cup
		Oil	2 tbsp
		Butter	2 tbsp
		Water As Required	
		Salt As Required	
<p>Method of Preparation: "Take warm water in a bowl. Add dry yeast, sugar, mix well and cover with a lid. Set it aside for 5 minutes. Take another mixing bowl. Add maida, oil, salt, milk powder, custard powder, butter, dry yeast and water. Mix well to make a smooth and soft dough. Punch the dough for 10 minutes. Set it aside for 15 minutes. Punch the dough again for 7 minutes. Set the dough batter in a bread tin and cover with a lid. Set it aside again for 20 minutes.</p> <p>Step 1: To preheat the oven, select category BB4, enter recipe code & press start.</p> <p>Step 2: When your oven beeps, arrange bread tin in on the turntable and press start. Cut and serve.</p>			

Category	Recipe-	Ingredients:	1 (230 gms)
BB5	BURGER /PAV	All Purpose Flour (Maida)	3 cups
		Salt	1 tsp
		Bread Improver	1 tsp
		Butter	3 tbsp
		Dry Yeast	1 tbsp
		Sugar	2 tsp
		Vanilla Powder	1 tsp
		Water As Required	
<p>Method of Preparation: "Take half a cup of warm water, add sugar, yeast and a pinch of flour, stir and cover. Keep aside for 5 minutes. Sieve the flour, add salt and mix, add the yeast water. Make soft dough using of water as required. add butter and knead the dough for 10 minutes. Cover the dough and leave in a warm place for 30 minutes, till the dough is al-most double in size. Knead the dough and make medium smooth roundels from it. Place them on a lightly greased baking try. Keep distance in between to let them rise and leave it for 20 minutes.</p> <p>Step 1: To preheat the oven, select category BB5, enter recipe code & press start.</p> <p>Step 2: When your oven beeps, arrange baking tray on the turntable and press start.</p>			

Category	Recipe-	Ingredients:	1 (230 gms)
BB6	DABELI KA PAV	All Purpose Flour	3 cup
		Butter	2½ tbsp
		Baking Powder	1 tsp
		Oil	2 tbsp
		Salt	1 tsp
		Butter For Basting (Optional)	
		Sesame Seeds (Optional)	
		Water Or Milk As Required	
		Yeast Preparation	
		Dry Yeast	2 tsp
		Water	1/2 cup
		Milk	3 tsp
		Sugar	2 tsp
<p>Method of Preparation: "Take half a cup of warm water. Add sugar, yeast and milk. Stir and cover. Keep aside for 5 minutes. Sieve the flour. Add all other ingredients, mix well, add the yeast water. Make soft dough using water or milk as required. Set it aside for 15 minutes. Knead the dough and make medium smooth roundels from it. Place them on a lightly greased baking tray. Keep distance between them to rise and leave it for 20 minutes.</p> <p>Step 1: For preheat the oven select category BB6, enter recipe code & press start.</p> <p>Step 2: When you hear a beep, arrange the baking tray on the low grill mesh rack and press start.</p>			

Category	Recipe-	Ingredients:	1 (230 gms)
BB7	FOCACCIA BREAD	All-Purpose Flour	2½ cups
		Salt	1 tsp
		Sugar	1 tsp
		Active Dry Yeast	1 tbsp
		Salt	1 tsp
		Garlic Powder	1 tsp
		Dried Oregano	1 tsp
		Dried Thyme	1 tsp
		Dried Basil	½ tsp
		Ground Black Pepper	a pinch
		Oil	2 tbsp
		Mozzarella Cheese	1 cup
		Olive Oil	2 tbsp
		Water As Required	

Method of Preparation: "In a large bowl, mix all ingredients other than cheese and olive oil to make a smooth, soft dough. Place the dough in the bowl, cover with a damp cloth and let it rise in a warm place for 30 minutes. Punch dough down and place it on greased baking tray. Pat into a 1/2 inch thick rectangle. Brush the top with olive oil. Sprinkle mozzarella cheese. Step 1: To preheat the oven, select category BB7, enter recipe code & press start.

Step 2: When your oven beeps, arrange baking tray on low grill mesh rack and press start. Serve warm."

Category	Recipe-	Ingredients:	1 (230 gms)
BB8	SANDWICH BREAD	All-Purpose Flour	2 cups
		Warm Water	½ cup
		Active-Dry Yeast	1 tsp
		Unsalted Butter	1 tbsp
		Milk Powder	3 tbsp
		Sugar	1tsp
		Oil	2 tbsp
		Salt To Taste	
		Water As Required	

Method of Preparation: "Take warm water in a bowl, add dry yeast, sugar and 2 tsp flour. Mix well and set it aside for 5 minutes. Take another mixing bowl, add maida, oil, salt, milk powder, butter, dry yeast and water. Mix well to make a smooth, soft dough. Punch the dough for 10 minutes. set it aside for 15 minutes. Punch the dough again for 5 minutes. Set the dough batter in a bread tin and cover it with a lid. Set it aside again for 20 minutes.

Step 1: To preheat the oven, select category BB8, enter recipe code & press start.

Step 2: When your oven beeps, arrange the bread tin on the turntable and press start. Cut and serve.

Category	Recipe-	Ingredients:	1 (230 gms)
BB9	PIZZA BASE	All Purpose Flour (Maida)	2 cups
		Salt	1 tsp
		Dry Yeast	2 tsp
		Sugar	1 tsp
		Oil	3 tsp
		Oregano	1 tsp
		Chili Flakes	1 tsp
		Water As Required	
<p>Method of Preparation: "Take half a cup of warm water. Add sugar, yeast and a pinch of flour. Stir and cover it. Keep it aside for 5 minutes. Sieve the flour, add salt, chili flakes, oregano, oil and mix well. Add the yeast water and make smooth and soft dough using water as required. Set it aside for 15 minutes. Roll out the dough. Place it on baking tray and prick with a fork. Cover and leave it for 20 minutes to double its size.</p> <p>Step 1: To preheat the oven select category BB9, enter recipe code & press start.</p> <p>Step 2: When your oven beeps, arrange the baking tray on the low grill mesh rack and press start. "</p>			

Category	Recipe-	Ingredients:	
BB10	BREAD TOAST	Bread Slices	
<p>Method of Preparation: "Arrange bread slices on the high grill mesh rack. Place the grill mesh rack in the oven.</p> <p>Step 1: Select category BB10, enter recipe code & press start.</p> <p>Step 2: When the oven beeps, turn the slices upside down and press start. "</p>			

Category	Recipe-	Ingredients:	1 (230 gms)
BB11	ROASTED SANDWICH	Bread Slices	8
		Onion Cut Into Round Slices	1 tsp
		Cucumber Cut Into Round Slices	2 tsp
		Tomatoes Cut Into Round Slices	1 tsp
		Green Capsicum Cut Into Thin Strips	3 tsp
		Green Mint And Coriander Chutney	1 tsp
		Cheese	1 tsp
		Tomato Ketchup	
		Chaat Masala	
		Salt To Taste	
<p>Method of Preparation: "Arrange paneer, onion, cucumber, tomato, capsicum slices on four bread slices. Sprinkle salt and chaat masala over them. Top it with a cheese slice. Apply one tablespoon green chutney on each of the remaining four slices. Top it with one tablespoon of tomato ketchup. Keep them on lightly greased crusty plate, place the crusty plate on the mesh rack in the microwave oven.</p> <p>Step 1: Select category BB11, enter recipe code & press start.</p> <p>Step 2: When the oven beeps, turn over & press start, serve hot"</p>			

Category	Recipe-	Ingredients:	1 (230 gms)
BB12	TANDOORI ROTI	Wheat Flour	1 cup
		Dry Yeast	1 tsp
		Sugar	1 tsp
		Curd	½ cup
		Oil To Finish Up The Dough	1 tbsp
		Ghee To Brush All The Rotis	4 tbsp
		Water As Required	
		Salt To Taste	
		Wheat Flour For Rolling	
<p>Method of Preparation: "Take warm water in a bowl. Add dry yeast, sugar. Mix well and cover it with a lid. Set it aside for 10 minutes. Take another mixing bowl, combine all the ingredients other than ghee, including the yeast mixture and knead it into a smooth, soft dough using enough water. Cover it with a damp cloth and keep it aside for 30 minutes. Divide the dough into 6 equal portions. Roll out each portion into a diameter of 5 inches. Use little dry flour for rolling the roti.</p> <p>Step 1: Keep the tawa on the low rack. Keep it inside the microwave. Select category BB12, enter recipe code & press start.</p> <p>Step 2: When the oven beeps, keep 2 rolled out roties on tawa & press start.</p> <p>Step 3: When the oven beeps again, turn & again press start. Make all the roties following the same procedure. Brush the ghee to the rotis and Serve hot."</p>			

Category	Recipe-	Ingredients:	1 (230 gms)
BB13	BUTTER NAAN	All Purpose Flour	1 cup
		Wheat Flour	¼ cup
		Sugar	1 tsp
		Instant Yeast	½ tsp
		Water As Required	
		Curd	2 tbsp
		Butter, Melted	1 tbsp
		Salt As Required	
		Butter For Spreading On The Naan	3 tbsp
<p>Method of Preparation: "Take warm water in a bowl. Add dry yeast, sugar, mix well and cover with lid. Set it aside for 5 minutes. Take another mixing bowl. Combine all the ingredients, including the yeast mixture and knead into a smooth, soft dough using enough water. Cover it with a damp cloth and keep it aside for 2 hours. Divide the dough into 6 equal portions. Roll out each portion into a diameter of 5 inches. Use little dry flour while rolling the roti.</p> <p>Step 1: Keep the tawa on the low rack. Keep it inside the microwave oven. Select the category BB13, enter recipe code & press start.</p> <p>Step 2: When the oven beeps, keep 2 rolled out naan roti on tawa & press start.</p> <p>Step 3: When the oven beeps, turn & again press start.</p> <p>Make all the naan roties following the same procedure. Brush the butter to the naan rotis and Serve hot."</p>			

Category	Recipe-	Ingredients:	1 (230 gms)
BB14	PLAIN PARATHA	Wheat Flour	1 cup
		Melted Butter	2 tbsp
		Butter Milk	¼ cup
		Ghee As Needed	
		Salt To Taste	
		Water As Required	
<p>Method of Preparation: "In a bowl combine wheat flour, salt, ghee. Rub them well. Gradually add milk & butter then water & knead a soft dough.</p> <p>Step 1: Keep tawa on the rack; keep inside the microwave to preheat the tawa. Select category BB14, enter recipe code & press start. Divide the dough into 5 equal portion (approx. of 45- 46 gms). Roll out each portion to a diameter of 6" spread ½ tsp ghee/oil all over & dust some dry flour. Fold to half & again repeat the same procedure. So that you get a long strip. Apply few drops of ghee on the strip. Again, roll the strip to form a ball. Roll out the ball to 5" diameter for paratha. When the oven beeps, remove the tawa keep 2 rolled out parantha on tawa & press start.</p> <p>Step 2: When the oven beeps, turn the parathas & again press start. Make all laccha parathas following the same procedure. Apply some ghee on top (optional) & crush the parantha slightly to open up the layers. Serve hot with gravy/curry of your choice. Wrap in foil & store. "</p>			

Category	Recipe-	Ingredients:	1 (230 gms)
BB15	ALOO PARATHA	For The Potato Stuffing:	
		Boiled & Mashed Potato	1 cup
		Green Chili, Chopped	2
		Coriander Leaves	2 tsp
		Ajwain	½ tsp
		Garam Masala	¼ tsp
		Chili Powder	¼ tsp
		Salt As Required	
		For The Dough:	
		Wheat Flour	2 cup
		Salt To Taste	
		Oil (Optional)	½ tsp
		Water As Required	
		For Frying The Parathas	
		Oil Or Ghee As Required	
<p>Method of Preparation: "In a bowl combine wheat flour, salt, ghee. Rub them well. Gradually add milk & butter then water & knead a soft dough.</p> <p>Step 1: Keep tawa on the rack; keep inside the microwave to preheat the tawa. Select category BB15, enter recipe code & press start. Divide the dough into 5 equal portion (approx. of 45- 46 gms). Roll out each portion to a diameter of 6" spread ½ tsp ghee/oil all over & dust some dry flour. Fold to half & again repeat the same procedure. So that you get a long strip. Apply few drops of ghee on the strip. Again, roll the strip to form a ball. Roll out the ball to 5" diameter for paratha. When the oven beeps, remove the tawa keep 2 rolled out paratha on tawa & press start.</p> <p>Step 2: When the oven beeps, turn the parathas & again press start. Make all laccha paranthas following the same procedure. Apply some ghee on top (optional) & crush the paratha slightly to open up the layers. Serve hot with gravy/curry of your choice. Wrap in foil & store. "</p>			

Category	Recipe-	Ingredients:	1 (230 gms)
BB16	KULCHA	Maida	1 cup
		Dry Yeast	1 tsp
		Sugar	1 tbsp
		Warm Water	50 ml
		Fresh Cream	2 tbsp
		Coriander Leaves	as required
		Kalonji	as required
		Oil	½ tsp
		Salt	a pinch
<p>Method of Preparation: "In a cup take warm water add dry yeast & add sugar. Stir well to dissolve. Keep aside for at least 5 minutes. In a mixing bowl take maida, salt & fresh cream. Mix well with hands. Add the yeast water & knead a firm dough. Pour ½ tsp oil & cover the dough and keep a side for 2 hours. Divide the dough into 4 equal portions (approx. 60gm each). Make balls & apply butter on top & sprinkle kalonji & coriander leaves on top. Press with fingers & dust with maida & roll out each ball into a diameter of 5". Keep the rolled dough on dusted multi cook tawa. Keep them covered in dark & warm place for at least 30 minutes.</p> <p>Step1: Select category BB16, enter recipe code & press start.</p> <p>Step 2: When the oven beeps, keep tawa with rolled doughs & press start.</p> <p>Step 3: Apply butter on top of kulchas or roast them a little & serve hot with chole."</p>			

Category	Recipe-	Ingredients:	1 (230 gms)
BB17	ALOO KULCHA	For The Potato Stuffing:	
		Boiled & Mashed Potato	1 cup
		Green Chili, Chopped	2
		Coriander Leaves	2 tsp
		Ajwain	½ tsp
		Garam Masala	¼ tsp
		Chili Powder	¼ tsp
		Salt As Required	
		For Kulcha:	
		Maida	1 cup
		Dry Yeast	1 tsp
		Sugar	1 tbsp
		Warm Water	50 ml
		Fresh Cream	2 tbsp
		Coriander Leaves	as required
		Kalonji	as required
		Oil	½ tsp
		Salt	a pinch
<p>Method of Preparation: "In a cup take warm water add dry yeast & add sugar. Stir well to dissolve. Keep aside for at least 5 minutes. In a mixing bowl take maida, salt & fresh cream. Mix well with hands. Add the yeast water, oil & knead a firm dough. Cover the dough and keep a side for 2 hours. Mix all stuffing ingredients, mix uniformly. Take two medium balls from the dough and roll the balls into small circles, apply butter on top & sprinkle kalonji & coriander leaves on top. Place a few tbsp of the filling on one of the dough circle. Press with fingers & dust with maida & roll out each ball into a diameter of 5". Keep the rolled dough on dusted multi cook tawa. Keep them covered in dark & warm place for at least 30 minutes.</p> <p>Step1: Select category BB17, enter recipe code & press start.</p> <p>Step 2: When the oven beeps, keep tawa with rolled doughs & press start.</p> <p>Step 3: Apply butter on top of kulchas or roast them a little & serve hot."</p>			

Category	Recipe-	Ingredients:	1 (230 gms)
BB18	GARLIC NAAN	Maida	230 gms
		Curd	4 tbsp
		Milk	100 ml
		Butter	1 tbsp
		Salt	1/8 tsp
		Castor Sugar	1 tsp
		Baking Powder	½ tsp
		Butter (Melted)	1 tsp
		Soda	¼ tsp
		Onion Seeds	1 tsp
		Garlic Paste	1 tsp
<p>Method of Preparation: "In a bowl sieve the flour, salt, sugar & baking powder. Rub in butter, curd & soda, add to the dough. Mix it well & knead a soft dough, add the milk & water (if required). After making the dough add melted butter & knead the dough again. Keep the dough covered in a warm place for about 2 hours to ferment properly.</p> <p>Step 1: Keep the tawa on low rack & keep inside the microwave. Select category BB18, enter recipe code & press start. Divide the dough into 10 equal portions/balls. (approx. of 40 gm each). Roll out each portion in an oblong shape. Brush with melted butter & sprinkle onion seeds on the top.</p> <p>Step 2: When the oven beeps, keep 2 rolled out naan on the tawa & press start.</p> <p>Step 3: When the oven beeps, turn and press start. Serve hot with gravy curry for your choice. "</p>			

Category	Recipe-	Ingredients:	1 (230 gms)
BB19	LACHHA PARATHA	Whole Wheat Flour	2 cups
		Ghee	2 Tbsp
		Milk	½ cup
		Water	½ cup
		Salt	½ tsp
<p>Method of Preparation: "In a bowl sieve the flour, salt, sugar & baking powder. Rub in butter, curd & soda, add to the dough. Mix it well & knead a soft dough adding all the seeds, milk & water (if required). After making the dough add melted butter & knead the dough again. Keep the dough covered in a warm place for about 2 hours to ferment properly.</p> <p>Step 1: Keep the tawa on the low rack & keep inside the microwave. Select category BB19, enter recipe code & press start. Divide the dough into 10 equal portions/balls. (approx. of 40 gm each). Roll out each portion in an oblong shape. Brush with melted butter & sprinkle onion seeds on the top.</p> <p>Step 2: When the oven beeps, keep 2 rolled out naan on the tawa & press start.</p> <p>Step 3: When the oven beeps, turn and press start. Serve hot with gravy curry for your choice. "</p>			

Category	Recipe-	Ingredients:	
BB20	TANDOORI NAAN	Maida	1 (230 gms)
		Curd	230 gr
		Milk For Brushing	4 tbsp
		Butter	100 ml
		Salt	1 tbsp
		Sugar	1/8 tsp
		Baking Powder	1 tsp
		Butter (Melted)	½ tsp
		Soda	1 tsp
		Onion Seeds	¼ tsp
		Kalonji Seeds	1 tsp
		Aniseeds	1 tsp
<p>Method of Preparation: "In a bowl sieve the flour, salt, sugar & baking powder. Rub in butter. curd & soda, add to the dough. Mix it well & knead a soft dough adding all the seeds, milk & water (if required). After making the dough add melted butter & knead the dough again. Keep the dough covered in a warm place for about 2 hours to ferment properly.</p> <p>Step 1: Keep the tawa on the low rack & keep inside the microwave. Select category BB20, enter recipe code & press start. Divide the dough into 10 equal portions/balls. (approx. of 40 gm each). Roll out each portion in an oblong shape. Brush with melted butter & sprinkle onion seeds on the top.</p> <p>Step 2: When the oven beeps, keep 2 rolled out naan on the tawa & press start.</p> <p>Step 3: When the oven beeps, turn and press start. Serve hot with gravy curry for your choice. "</p>			

Category	Recipe-	Ingredients:	
BB21	TART	All-Purpose Flour, Plus	
		More As Needed	1¼ cups
		Sugar Powder	8 tbsp
		Salt To Taste	3 tbsp
<p>Method of Preparation: "Combine the butter, sugar, and salt in a large bowl and stir until evenly incorporated. Add the flour and stir until a soft dough forms. Sprinkle the dough over the bottom of a 9-inch tart pan with a removable bottom. Using your fingers, evenly press the dough into the bottom and top side of the pan. Cover the tart shell with plastic wrap and let it rest in the refrigerator for 30 minutes. Once chilled, prick it all over with a fork.</p> <p>Step 1: Select category BB21, enter recipe code & press start.</p> <p>Step 2 : When the oven beeps, keep tart pan on the grill mesh rack in the oven & press start.</p> <p>Step 3: Apply little butter on the top of the tart and press start.."</p>			

Category	Recipe-	Ingredients:	
BB22	BREAD CRUMBS	Bread Slices	
			4
<p>Method of Preparation: Place the bread slices on the grill mesh rack in the oven.</p> <p>Step 1:- Select BB22, enter recipe code and press start. After beep, remove and grind for breadcrumbs.</p> <p>Step 2 : When the oven beeps, keep tart pan on the grill mesh rack in the oven & press start.</p> <p>Step 3: Apply little butter on the top of the tart and press start.."</p>			

TADKA / CURRIES

Category	Recipe-	Ingredients:	
TC1	TADKA / CHOWK/ VAGHAR	Oil / Ghee	3 tbsp
		Green Chillies	3
		Chopped Onions	2
		Jeera	1 tsp
		Garlic	½ tsp
		Ginger	½ tsp
		Hing	½ tsp
		Mustard Seeds	½ tsp
		Turmeric Powder	½ tsp
		Red Chili Powder	½ tsp
		Curry Leaves	Few
		Cinnamon	3
		Cardamom	4
		Bay Leaves	3
		Coriander	Few
		Cloves	3
		Pepper Corns	6
<p>Method of Preparation: Take a microwave oven safe bowl, add the ingredients according to the recipe, mix well. Select Category TC1, enter recipe code and press start. When the oven beeps, remove and use it for seasoning your dish.</p>			

Category	Recipe-	Ingredients:	
TC2	SCHEZWAN CHICKEN	Boneless Chicken	250 gr
		Spring Onions	¾ cup
		Tomato Ketchup	2 tbsp
		Dry Red Chillies	2 nos.
		Garlic Paste	1 tsp
		Red Chilli Sauce	1 tsp
		Ajinomoto	1 tbsp
		Vinegar	¼ tsp
		Sugar	1 tsp
		Corn flour (Mixed With¼ Cup Water)	2 tsp
		Oil	2 tbsp
		Salt To Taste	
<p>Method of Preparation: "Step 1: Take a microwave oven safe bowl, add all ingredients other than chicken, ketchup, vinegar, corn flour and mix well. Select category TC2, enter recipe code & press start. Step 2: When the oven beeps, remove and add all remaining ingredients, mix well and & press start. Serve hot.</p>			

Category	Recipe-	Ingredients:	250 gr
TC3	KASHMIRI KAJU PANEER	Paneer Pieces	250 gr
		Kaju Paste	4 tsp
		Onions Chopped	¾ cup
		Chopped Ginger	1 tsp
		Chopped Garlic	1 tsp
		Chilli Powder	1 tsp
		Khus Khus Paste	3 tbsp
		Tomato Puree	1 cup
		Milk	1 cup
		Garam Masala	1 tsp
		Salt To Taste	
<p>Method of Preparation: "Step 1: Take a microwave oven safe bowl, add all ingredients other than paneer, kaju paste, khus khus paste, tomato puree and mix well. Select category TC3, enter recipe code & press start. Step 2:When the oven beeps, remove and add all remaining ingredients, mix well and & press start. Serve hot." "</p>			

Category	Recipe-	Ingredients:	250 gr
TC4	KADHI	Yogurt	2 cup
		Besan	4 tsp
		Grated Ginger	½ tsp
		Turmeric Powder	¼ tsp
		Ghee	½ tbsp
		Dry Red Chillies	2
		Curry Leaves	Few
		Chopped Green Chillies	1
		Hing	a pinch
		Sugar	1 tsp
		Cumin Seeds	½ tsp
		Mustard Seeds	½ tsp
		Salt To Taste	
		Chopped Coriander Leaves For Garnish	
		Water As Required	
<p>Method of Preparation: "Step 1: Beat the yogurt, water & besan in a vessel so that no lumps are formed. Take a microwave oven safe bowl, add all the ingredients other than yogurt, besan, water mixture and mix well. Select category TC4, enter recipe code, press start. Step 2: After the beep, Remove and add the remaining ingredients and mix well and press start. Remove and garnish with coriander leaves and serve."</p>			

Category	Recipe-	Ingredients:	250 gr
TC5	HONEY CHILLI POTATO	Potatoes, Sliced	2 cup
		Onion, Finely Chopped	1 cup
		Spring Onions, Chopped Round	¼ cup
		Tomatoes, Chopped	½ cup
		Garlic & Ginger Paste	1 tsp
		Soya Sauce	1 tsp
		Tomato Ketchup	1 tbsp
		Chili Sauce	1 tsp
		Honey	1 tbsp
		Maida	1 tbsp
		Corn Flour	1 tbsp
		Parsley	1 tbsp
		Oregano	¼ tsp
		Red Chilli Powder	1 tsp
		Salt To Taste	
		Oil As Required	
<p>Method of Preparation: "Step 1: Take a microwave oven safe bowl, add oil, sliced potatoes, maida, corn flour and mix well. Select category TC5, enter recipe code and press start. Step 2: After the beep, remove and add some more oil and all remaining ingredients, mix well and press start. Serve hot."</p>			

Category	Recipe-	Ingredients:	250 gr
TC6	PANEER PEAS CURRY	Paneer Cubed	250 gms
		Green Peas	½ cup
		Onions	2
		Tomato Puree	1½ cup
		Ginger, Garlic Paste	1½ tsp
		Coriander Powder	½ tsp
		Cumin Powder	½ tsp
		Garam Masala	½ tsp
		Turmeric Powder	¼ tsp
		Green ChilliesChopped	3
		Heavy Cream	¼ cup
		Oil As Required	
		Salt To Taste	
		Coriander Leaves For Garnish	
<p>Method of Preparation: Take a microwave oven safe bowl, add all the ingredients other than paneer, tomato puree, heavy cream, coriander leaves and salt and mix well. Select category TC6, enter recipe code & press start. Step 2: When the oven beeps, remove and add the remaining ingredients other than the coriander leaf and mix well and press start. Remove, garnish with coriander leaves and serve.</p>			

Category	Recipe-	Ingredients:	250 gr
TC7	PRAWNS MATAR CURRY	Prawns	2 cup
		Green Peas	¼ cup
		Onion	1 cup
		Tomato	¼ cup
		Ginger Garlic Paste	1 tsp
		Green Chilli	¼ tsp
		Chilli Powder	1 tsp
		Turmeric Powder	¼ tsp
		Garam Masala Powder	1 tsp
		Coriander Leaves	2 tbsp
		Salt To Taste	
		Oil As Required	

Method of Preparation: "Step 1: Take a microwave oven safe bowl, add all the ingredients other than prawns, tomato, mix well, select category TC7, enter recipe code & press start.

Step 2: When beep, Remove and add the remaining ingredients, mix well and press start. Remove and Serve hot."

Category	Recipe-	Ingredients:	250 gr
TC8	KASHMIRI PANEER MASALA	Paneer Pieces	250 gr
		Sliced Onions	1 cup
		Tomato Puree	1 cup
		Yogurt	2 tbsp
		Khus Khus Paste	3 tbsp
		Milk	1 cup
		Chopped Ginger	3 tsp
		Chopped Garlic	2 tsp
		Kashmiri Chilli Powder	1 tsp
		Garam Masala	
		Salt To Taste	

Method of Preparation: "Step 1: Take a microwave oven safe bowl, add all the ingredients other than paneer, tomato puree, milk, yogurt and mix well. Select category TC8, enter recipe code and press start.

Step 2: After the beep, remove and add the remaining ingredients, mix well and press start. Remove and Serve hot."

Category	Recipe-	Ingredients:	250 gr
TC9	CHILI SOYA NUGGETS	Soya Nuggets, Soaked	250 gr
		Spring Onions, Chopped	1 cup
		Garlic Paste	1 tsp
		Green Chillies, Sliced	1 tsp
		Soya Sauce	3 tbsp
		Vinegar	1 tsp
		Coriander Leaves For Garnish	3 tbsp
		Salt To Taste	
		Oil As Required	

Method of Preparation: "Step 1: Take a microwave oven safe bowl, add all the ingredients other than soya nuggets, soya sauce, coriander leaves and mix well. Select category TC9, enter recipe code & press start.

Step 2: After the beep, remove and add the remaining ingredients other than coriander leaves, mix well and press start. Remove and garnish with coriander leaves. Serve hot."

Category	Recipe-	Ingredients:	
TC10	PRAWNS VINDALOO	Shelled Prawns	250 gr
		Tomatoes, Chopped	1½ cup
		Cumin Seeds	1 tsp
		Ginger, Garlic Paste	1½ tsp
		Curry Leaves	Few
		Chili Powder	1½ tsp
		Turmeric Powder	¼ tsp
		Vinegar	1 tbsp
		Corn Flour	1 tbsp
		Sugar	1½ tsp
		Salt To Taste	
<p>Method of Preparation: "Step 1: Take a microwave oven safe bowl, add all the ingredients other than prawns and vinegar and mix well. Select category TC10, enter recipe code and press start. Step 2: After the beep, remove, add the remaining ingredients, mix well, and press start. Remove and serve hot."</p>			

Category	Recipe-	Ingredients:	
TC11	CRAB CURRY	Big Size Crabs	5
		Big Size Onion Sliced	2
		Red Chilies Whole	2
		Tamarind Pulp	1½ tbsp
		Cumin Seeds	1 tsp
		Coconut Scraped	1½ tbsp
		Garam Masala Powder	1½ tsp
		Garlic & Ginger Paste	1 tsp
		Turmeric Powder	1 tbsp
		Oil As Required	
		Water As Required	
		Salt To Taste	
<p>Method of Preparation: "Clean the crabs, only the body and claws are used (the crab claws can be lightly cracked and the body cut into half, to facilitate eating). Grind the scraped coconut with red chilies, cumin seeds, turmeric powder and garlic to a fine paste. Step 1: Take a microwave oven safe bowl, add all ingredients other than tamarind pulp and water, mix well and select category TC11, enter recipe code & press start. Step 2: After the beep, remove and add tamarind pulp, water, mix well and press start. Serve hot."</p>			

Category	Recipe-	Ingredients:	250 gms
TC12	DUM ALOO	Aloo (Potatoes)	250 gms
		Ghee	1½ tbsp
		Tomato Puree	1½ cup
		Curd	½ cup
		Spices	
		Cloves	3
		Bay Leaves	2
		Black Peppercorns	5
		Green Cardamoms	3
		Brown Cardamom	3
		Cinnamon Stick	2
		Paste	
		Onion (Chopped)	2
		Flakes Garlic	4
		Ginger	½" inch
		Black Peppercorns	5
		Poppy Seeds	½ tsp
		Coriander Seeds	½ tsp
		Cumin Seeds	½ tsp
		Dry Red Chillies	3
		Turmeric Powder	¼ tsp
		Ground Mace	a pinch
		Ground Nutmeg	a pinch
		Salt To Taste	

Method of Preparation: "Step 1: Take a microwave oven safe bowl, add all the ingredients other than potato, tomato puree, curd and all the paste items. Mix well and select category TC12, enter recipe code & press start.

Step 2: After the beep, remove and add the remaining ingredients, mix well and press start. Remove and Serve hot."

Category	Recipe-	Ingredients:	
TC13	CAPSICUM CURRY	Capsicum, Chopped	250 gms
		Onion, Chopped	1½ cup
		Green Chillies, Slit Lengthwise	4
		Ginger Paste	1 tsp
		Garlic Paste	1 tsp
		Turmeric Powder	½ tsp
		Chole Masala	1 tbsp
		Cumins Seeds	1 tsp
		Mustard Seeds	1 tsp
		Oil As Required	
		Salt To Taste	
		Water As Required	

Method of Preparation: "Step 1: Take a microwave oven safe bowl, add all the ingredients other than capsicum, chole masala and water. Mix well and select category TC13, enter recipe code & press start.

Step 2: After the beep, remove and add the remaining ingredients, mix well and press start. Remove and Serve hot."

Category	Recipe-	Ingredients:	
TC14	KARELA FRY	Karela (Cut Into Thin Round)	250 gms
		Lemon Juice	2 tsp
		Turmeric Powder	¾ tsp
		Red Chilli Powder	1½ tsp
		Jeera Powder	1½ tsp
		Garam Masala	1½ tsp
		Oil As Required	
		Salt To Taste	
<p>Method of Preparation: "Marinate karela with the lemon juice, turmeric, salt for 20 minutes and wash it well. Step 1: Take a microwave oven safe bowl, add all the ingredients other than garam masala and mix well. Select category TC14, enter recipe code & press start. Step 2: After the beep, remove and add the remaining ingredients, mix well and press start. Remove and Serve hot."</p>			

Category	Recipe-	Ingredients:	250 gms
TC15	TAMATAR KA SHORBA	Tomatoes, Chopped	1½ cup
		Chopped Ginger	¾ tsp
		Chopped Garlic	¾ tsp
		Green Chili	¾ tsp
		Garam Masala	¾ tsp
		Bay Leaf	3
		Chopped Green Coriander	2½ tbsp
		Cumin Seeds	¾ tsp
		Sugar	¾ tsp
		Salt To Taste	
		Oil As Required	
<p>Method of Preparation: "Step 1: Take a microwave oven safe bowl, add all ingredients other than tomatoes, sugar and mix well. Select category TC15, enter recipe code & press start. Step 2: After the beep, remove and add all the remaining ingredients, mix well and press start. Serve hot. "</p>			

Category	Recipe-	Ingredients:	250 gms
TC16	GOBI SUBZI	Cauliflower Florets	¾ cup
		Green peas	¾ cup
		Chopped Cabbage	¾ cup
		Green Chillies	3
		Cashew Nut Paste	¾ cup
		Garam Masala	2 tsp
		Curd	1½ cup
		Oil As Required	
<p>Method of Preparation: " Step1: Take a microwave oven safe bowl, add all ingredients other than cabbage, green peas and curd and mix well. Select category TC16, enter recipe code & press start. Step 2: After the beep, remove and add all remaining ingredients, mix well and press start. Serve hot."</p>			

Category	Recipe-	Ingredients:	
TC17	ALOO GOBI	Cauliflower Florets	1 cup
		Potatoes Sliced	1 cup
		Ginger Chopped	1 tsp
		Turmeric Powder	¼ tsp
		Red Chili Powder	1 tsp
		Garam Masala	1 tsp
		Oil As Required	
		Salt To Taste	
		Coriander Leaves For Garnish	

Method of Preparation: Step 1: In a microwave oven safe bowl add all ingredients other than cauliflower, coriander leaves, mix well. Select category TC17, enter recipe code and press start. Step 2: When the oven beeps, remove and add other remaining ingredients other than coriander leaves, mix well and press start. Garnish with coriander leaves. Serve hot.

Category	Recipe-	Ingredients:	
TC18	KADDU KI SUBZI	Kaddu (cut into pieces)	250 gr
		Chopped tomato	1 cup
		Chopped green chilli	1 tsp
		Finely chopped ginger	1 tsp
		Garam masala	1 tsp
		Red chilli power	1 tbsp
		Turmeric powder	¼ tsp
		Amchoor powder	1 tsp
		Oil as required	
		Salt to taste	
		Coriander leaves for garnish	

Method of Preparation: "Step 1: In a microwave oven safe bowl add all ingredients other than kaddu, tomato, coriander leaves, mix well. Select category TC18, enter recipe code and press start. Step 2: When the oven beeps, remove and add other remaining ingredients other than coriander leaves, mix well and press start. Serve hot."

Category	Recipe-	Ingredients:	
TC19	JEERA ALOO	Potatoes, Chopped	250 gr
		Cumin Seeds	2 tsp
		Green Chilies, Chopped	1 tsp
		Turmeric Powder	¼ tsp
		Red Chili Powder	1 tsp
		Lemon Juice	1 tsp
		Oil As Required	
		Salt As Per Taste	
		Coriander Leaves For Garnish	

Method of Preparation: "Step 1: In a microwave oven safe bowl add all ingredients other than potatoes, lemon juice, coriander leaves, mix well. Select category TC 19, enter recipe code and press start. Step 2: When the oven beeps, remove and add other remaining ingredients other than coriander leaves, mix well and press start. Serve hot."

Category	Recipe-	Ingredients:	
TC20	TANDOORI SUBZI	Paneer cubes	¾ cup
		Capsicum Cut into fine rings	¾ cup
		Onion Cut into fine rings	¾ cup
		Tandoori Color	pinch of
		Tandoori Masala	2 tsp
		Ginger, Garlic paste	2 tsp
		Red chilli powder	1 tsp
		Green Chillies	1 tsp
		Jeera	1 tsp
		Lemon juice	1 tsp
		Oil as required	
		Salt to taste	

Method of Preparation: Step 1: In a mixing bowl, add all ingredients, mix well and set it aside for 20 minutes to marinate. Place all marinated ingredients in the crispy plate, on the grill mesh rack. Select category TC20, enter recipe code and press start.

Step 2: When the oven beeps, remove and turn smoothly and press start. Serve hot.

Category	Recipe-	Ingredients:	
TC21	MALAI KHUMB	Sweet Corn Kernels	¾ cup
		Mushrooms	¾ cup
		Cupcapsicum Cubes	¾ cup
		Cumin Seeds	1 tsp
		Onions Chopped	¾ cup
		Green Chillies	2
		Ginger, Garlic	1 tsp
		Cumin Seeds Powder	1 tsp
		Chilli Powder	1 tsp
		Tomatoes	¾ cup
		Tomato Ketchup	2 tbsp
		Corn flour	2 tbsp
		Sugar	1 tsp
		Salt To Taste	
		Oil	
		Coriander For Garnish	

Method of Preparation: Step 1: In a mixing bowl, add all ingredients, mix well and set it aside for 20 minutes for marinate. Place all marinated ingredients in the crispy plate on the grill mesh rack. Select category TC21, enter recipe code and press start. Garnish with coriander leaves. Serve hot.

Category	Recipe-	Ingredients:	
TC22	MOONG DAL	Yellow Lentils (Moong Dal)	1½ cup
		Tomato Chopped	3
		Onion Chopped	1½
		Red Chilli Powder	1½ tsp
		Turmeric Powder	¼ tsp
		Ginger Paste	¾ tsp
		Garlic Paste	¾ tsp
		Green Chillies Chopped	3
		Mustard Seeds	¼ tsp
		Dried Red Chillies	3
		Salt To Taste	
		Water As Required	
		Oil As Required	
		Coriander Leaves For Garnish	
<p>Method of Preparation: Step 1: In a microwave oven safe bowl add all ingredients other than lentils, tomatoes, water, coriander leaves and mix well. Select category TC22, enter recipe code and press start. Step 2: When the oven beeps, remove and add other remaining ingredients other than coriander leaves, mix well and press start. Serve hot.</p>			

Category	Recipe-	Ingredients:	
TC23	AMRITSARI DAL	Urad Dal	1 cup
		Chana Dal	1 cup
		Tomatoes	1 cup
		Onion Chopped	1 cup
		Mint Leaves	Few
		Ginger, Garlic Paste	1 tsp
		Green Chillies Chopped	2
		Butter As Required	
		Salt To Taste	
<p>Method of Preparation: Step 1: In a microwave oven safe bowl add all ingredients other than urad dal, tomato, chana dal and mix well. Select category TC23, enter recipe code and press start. Step 2: When the oven beeps, remove and add other remaining ingredients, mix well and press start. Serve hot.</p>			

Category	Recipe-	Ingredients:	200 gr
TC24	TADKA DAL	Red Lentils (Masoor Dal)	1 cup
		Yellow Lentils (Moong Dal)	1 cup
		Tomato Chopped	2
		Onion Chopped	1
		Oil	1 tbsp
		Red Chilli Powder	1 tsp
		Turmeric Powder	¼ tsp
		Ginger Paste	½ tsp
		Garlic Paste	½ tsp
		Green Chillies Chopped	2
		Mustard Seeds	¼ tsp
		Dried Red Chillies	2
		Coriander Leaves For Garnish	
		Salt To Taste	
		Water As Required	

Method of Preparation: "Step 1: In a microwave oven safe bowl add all ingredients other than red lentils, yellow lentils, tomato, water, coriander leaves and salt and mix well. Place the bowl in the microwave oven, select category TC24, enter recipe code and press start.

Step 2: After the oven beeps, Remove, add the remaining ingredients other than coriander leaves and mix well and press start. Remove, garnish with coriander leaves and serve hot."

Category	Recipe-	Ingredients:	200 gr
TC25	MUTTON MINCE	Mutton mince (kheema)	200 gr
		Green peas	1 cup
		Onion	1 cup
		Tomato puree	1 cup
		Ginger-Garlic paste	1 tsp
		Red chili powder	1 tsp
		Garam masala	1 tsp
		Turmeric powder	¼ tsp
		Oil	2 tbsp
		Salt to taste	
		Coriander for garnishing	

Method of Preparation: Step 1: In a microwave oven safe bowl add all ingredients other than mince, tomato puree, coriander leaves and mix well. Select category TC25, enter recipe code and press start.

Step 2: When the oven beeps, remove and add other remaining ingredients than coriander leaves, mix well and press start. Serve hot.

Category	Recipe-	Ingredients:	
TC26	KOOTTU CURRY	Bengal Gram Dal (Chana Dal)	1 cup
		White Gram Dal (Urad Dal)	1½ tbsp
		Pumpkin (Cut Into Small Pieces)	1 cup
		Snake Gourd (Cut Into Small Pieces)	1 cup
		French Beans (Cut Into Small Pieces)	1 cup
		Yam (Cut Into Small Pieces)	1 cup
		Cucumber (Cut Into Small Pieces)	1 cup
		Inner Flesh Of Drum Stick Pieces	1 cup
		Grated Coconut Paste	1 cup
		Turmeric Powder	1 tsp
		Green Chillies Paste	1 tsp
		Mustard Seeds	¼ tsp
		Dried Red Chillies	5
		Curry Leaves	Few
		Ghee Or Coconut Oil	2 tbsp
		Salt To Taste	
		Water As Required	
<p>Method of Preparation: Step 1: In a microwave oven safe bowl add all ingredients other than chana dal, urad dal, pumpkin, snake gourd, french beans, yam, cucumber, drumsticks and water, mix well and Select category TC26, enter recipe code and press start.</p> <p>Step 2: When the oven beeps, remove, add the remaining ingredients except coriander leave, mix well and press start. Serve hot.</p>			

Category	Recipe-	Ingredients:	
TC27	ACHARI MUTTON	Mutton	3 cup
		Tomatoes	2
		Onions	2
		Fenugreek Seeds	1 tsp
		Fennel Seeds	1 tsp
		Cumin Seeds	1 tsp
		Turmeric Powder	½ tsp
		Dried Red Chilli	3
		Red Chilli Powder	2 tsp
		Cloves	4
		Ginger, Garlic Paste	2 tsp
		Mustard Seeds	1 tsp
		Coriander Leaves For Garnish	
		Oil As Required	
		Salt To Taste	
<p>Method of Preparation: Step 1: In a microwave oven safe bowl add all ingredients other than mutton, tomato and coriander leaves, mixwell and Select category TC27, enter recipe code and press start. Step 2: When the oven beeps, remove, add the remaining ingredients other than coriander leaves and mix well and press start. Remove, and garnish with coriander leaves. Serve hot.</p>			

Category	Recipe-	Ingredients:	
TC28	PULISSERI	Grated Coconut	2 cup
		Onion, Finely Chopped	1
		Curds	3 cup
		Cumin Seeds (Jeera)	½ tsp
		Coriander Powder	½ tsp
		Fenugreek Seeds (Methi)	½ tsp
		Garlic Paste	½ tsp
		Turmeric Powder	¼ tsp
		Mustard Seeds	½ tsp
		Curry Leaves	Few
		Green Chili, Broken	1
<p>Method of Preparation: Step 1: In a microwave oven safe bowl add all ingredients other than curd and mix well. Select category TC28, enter recipe code and press start. Step 2: When the oven beeps, remove, add the remaining ingredients, mix well and press start. Serve hot.</p>			

Category	Recipe-	Ingredients:	
TC29	SHAHI SHORBA	Onions, Chopped	1½ cup
		Butter Melted	3 tbsps
		Whole Wheat Flour	3 tbsps
		Mint Leaves Paste	3 tbsps
		Coarsely Chopped Walnuts	1½ tsp
		Sugar	2 tsp
		Black Pepper Powder	½ tsp
		Salt To Taste	
		Water As Required	
<p>Method of Preparation: Step 1: Take a microwave oven safe bowl, Add butter, wheat flour, onions and mix well. Select category TC29, enter recipe code and press start. Step 2: When the oven beeps, remove, and add all remaining ingredients, mix well and press start. Serve hot.</p>			

Category	Recipe-	Ingredients:	
TC30	MIX VEGETABLE CURRY	Carrots (Cut Into Pieces)	¼Cup
		Potatoes (Cut Into Pieces)	¼Cup
		French Beans (Chopped)	¼ cup
		Green Peas (Chopped)	¼ cup
		Tomato (Chopped)	¼ cup
		Onion (Chopped)	2
		Mustard	¼ tsp
		Garlic Ginger Paste	½ tsp
		Red Chili Powder	1 tsp
		Turmeric Powder	¼ tsp
		Bay Leaves	2
		Cinnamon	2" stick
		Cloves	Few
		Cumins	1 tsp
		Garam Masala	1 tsp
		Oil As Required	
		Salt To Taste	
		Coriander Leaves For Garnish	
<p>Method of Preparation: Step 1: In a microwave oven safe bowl add all ingredients other than carrots, potato, beans, green peas, tomato and coriander leaves and mix well. Select category TC30, enter recipe code and press start.</p> <p>Step 2: when the oven beeps, remove, Remove, add the remaining ingredients other than the coriander, mix well, and press start. Remove, garnish with coriander leaves and serve.</p>			

Category	Recipe-	Ingredients:	
TC31	CHICKEN SHORBA	Boneless Chicken Shredded	2 cup
		Chicken Stock	2 cup
		Cumin Seeds	1 tsp
		Flour	1 cup
		Fresh Cream	1 cup
		Butter As Required	1 cup
		Salt & Pepper To Taste	
<p>Method of Preparation: "Step 1: Take a microwave oven safe bowl, add all the ingredients other than chicken stock, flour, fresh cream and mix well. Select category TC31, enter recipe code & press start.</p> <p>Step 2: When the oven beeps, remove and add all remaining ingredients, mix well and press start. Serve hot."</p>			

Category	Recipe-	Ingredients:	
TC32	MURG KESARI	Chicken cut into pieces	250 gr
		For Kesari gravy:	
		White onion paste	1 cup
		Almond paste	2 tbsp
		Cashew paste	2 tbsp
		Cream	¼ cup
		Curd	½ cup
		Lemon juice	1 tsp
		Peppercorns	Few
		Cumin	½ tsp
		Green cardamoms	Few
		Cloves	Few
		Saffron strands	Few
		Red chili powder	1 tsp
		Green chilies chopped	1 tsp
		Ginger paste	1 tsp
		Bay leaf	Few
		Butter	2 tbsp
		Water as required	
		Salt to taste	
		Chopped coriander for garnish	
<p>Method of Preparation: "Step 1: Take a microwave oven safe bowl, add all ingredients other than chicken and mix well. Select category TC32, enter recipe code & press start. Step 2: When the oven beeps, remove and add all remaining ingredients, mix well and press start. Serve hot."</p>			

Category	Recipe-	Ingredients:	
TC33	FISH BARTA	Fish Bones Removed	250 gr
		Onion, Finely Chopped	1 cup
		Tomatoes, Finely Chopped	1 cup
		Chopped Garlic	1 tsp
		Green Chili, Chopped	1 tsp
		Red Chili Powder	1 tsp
<p>Method of Preparation: Step 1: Take a microwave oven safe bowl and add the fish. Select category TC33, enter recipe code & press start. After the beep, remove fish bones and smash them well. Step 2: Add all remaining ingredients other than coriander leaves, mix well and press start. After the beep, remove and garnish with coriander leaves. Serve hot.</p>			

Category	Recipe-	Ingredients:	
TC34	PANEER BHURJI	Paneer Grated	250 gms
		Oil	½ tsp
		Cumin Seeds	3
		Green Chillies	1 cup
		Onion Chopped	¼ tsp
		Turmeric powder	1 tsp
		Garam Masala Powder	1 tsp
		Ginger-Garlic Paste	1 tsp
		Tomatoes	1 cup
		Salt To Taste	
<p>Method of Preparation: "Step 1: Take a microwave oven safe bowl, add all the ingredients other than grated paneer, tomato and salt and mix well. Select category TC34, enter recipe code and press start. Step 2: When the oven beeps, remove, and add tomato, mix well and press start. Step 3: When the oven beeps, remove and add grated paneer, salt, mix well and press start. Serve hot."</p>			

Category	Recipe-	Ingredients:	
TC 35	CHINGIRI MALAI KARI	King Prawns	1 tsp
		Turmeric Powder	1 tsp
		Red Chili powder	
		Salt to taste	
		For Gravy:-	
		Onion Chopped	1 cup
		Coconut Milk	1 cup
		Green Chili	1 tsp
		Red Chili Powder	½ tsp
		Ginger, Garlic Paste	1 tsp
		Cinnamon Stick	3
		Cloves	Few
		Peppercorns	Few
		Bay leafs	3
		Cumin Seeds	1 tsp
		Garam Masala	1 tsp
		Sugar	½ tsp
		Salt to taste	
		Oil as required	
		Water as required	
<p>Method of Preparation: Place Prawns in a mixing bowl, Sprinkle on the salt, turmeric powder, red chili powder and mix well, set aside for 10 minutes. Step 1:-Take a microwave oven safe bowl, add all gravy ingredients other than coconut milk and water mix well and place it in the oven. Select category TC35, enter recipe code and press start. Step 2:- After beep, remove, add prawns, coconut milk and press start. Step 3:- When beep, remove, add water, mix well and press start. Serve hot.</p>			

Category	Recipe-	Ingredients:	
TC36	RIDGE GUARD CURRY	Ridge Gourd (Peeled & Chopped)	2 cup
		Moong Dal	½ cup
		Urad Dal	½ cup
		Jeera	¾ tsp
		Mustard Seeds	½ tsp
		Red Chilli Powder	1½ tsp
		Onion (Chopped)	1½ cup
		Curry Leaves	Few
		Whole Red Chillies	3
		Turmeric Powder	¼ tsp
		Fresh Coconut	½ cup
		Hing	a pinch
		Oil as required	
		Salt to taste	
<p>Method of Preparation: "Step 1: Take a microwave oven safe bowl, add all ingredients other than ridge gourd, salt. Mix well. Select category TC36, enter recipe code and press start. Step 2: When the oven beeps, remove the bowl, add the remaining ingredients mix well and press start. Remove and serve."</p>			

Category	Recipe-	Ingredients:	
TC37	FISH MASALA	Fish	250 g
		Onion Chopped	1 cup
		Tomato Chopped	½ cup
		Green Chillies, Chopped	½ tsp
		Coriander Leaves	2 tbsps
		Garam Masala	1 tsp
		Turmeric Powder	⅛ tsp
		Coriander Powder	½ tsp
		Chili Powder	1 tsp
		Lemon Juice	½ tsp
		Ginger-Garlic Paste	½ tsp
		Water As Required	
		Oil As Required	
		Salt to taste	
<p>Method of Preparation: "Step 1: Take a microwave oven safe bowl, add all ingredients other than fish, tomato, coriander leaves, water and mix well. Select category TC37, enter recipe code & press start. Step 2: When the oven beeps, remove and add all remaining ingredients, mix well and press start. Serve hot."</p>			

Category	Recipe-	Ingredients:	
TC38	BUTTER CHICKEN	Boneless Chicken	250gms
		Yogurt	1 tbsp
		Lime Juice	1 tsp
		Red Chilli Powder	1 tsp
		Roasted Cloves	2
		Roasted Pepper Corns	2
		Roasted Cinnamon	½ inch
		Cardamom	2
		Roasted Almonds	3
		Bay Leaves	1
		Oil	½ tbsp
		Chopped Onions	1
		Garlic Paste	½ tsp
		Ginger Paste	½ tsp
		Coriander Powder	½ tsp
		Cumin Powder	½ tsp
		Turmeric Powder	¼ tsp
		Tomato Puree	1 tbsp
		Chicken Stock	1 cup
		Kasuri Methi	1 tsp
		Butter	½ tbsp
		Salt To Taste	
		Coriander Leaves For Garnish	

Method of Preparation: "Grind & make a paste of cloves, pepper corns, cinnamon, almonds & cardamom. Marinate the chicken with the above paste and butter, yogurt, salt, lime juice, red chilli powder, bay leaves, coriander, cumin, turmeric powder & set aside for 1 hour.

Step 1: Take a microwave oven safe bowl, Add oil, onion, garlic, ginger paste mix well, select category TC 38, enter recipe code & press start.

Step 2: when the oven beeps, remove, add the remaining ingredients, mix well, and press start. Remove and garnish with coriander leaves and serve."

Category	Recipe-	Ingredients:	
TC39	SHAHI PANEER	Paneer (Cut In Thin Slices)	2 cups
		Milk	1 tsp,
		Turmeric Powder	1 tbsp
		Fennel (Saunf) Grinded	2
		Bay Leaves	4
		Cardamoms	2
		Sticks Cinnamon	1tsp
		Cumin Seeds	4
		Fresh Seedless Green Chilies	
		Salt To Taste	

Method of Preparation: Step 1: Take a microwave oven safe glass bowl, add all the ingredients other than paneer slices, fennel (Saunf powder), milk and mix well, select category TC39, enter recipe code press start. Step 2: when the oven beeps, remove, add all remaining ingredients, mix well smoothly, and press start. Remove and serve.

Step 2: when the oven beeps, remove, add the remaining ingredients, mix well, and press start. Remove and garnish with coriander leaves and serve."

Category	Recipe-	Ingredients:	
TC40	KARELA KA SUBJI	Karela, Chopped	2 cups
		Onion, Finely Chopped	1 tsp,
		Besan	1 tbsp
		Green Chilli, Finely Chopped	2
		Ginger, Garlic Paste	4
		Fresh Coriander, Chopped	2
		Oil As Required	1tsp
		Red Chilli Powder	4
		Coriander Powder	
		Turmeric Powder	
		Amchoor Powder	
		Cumin Seeds	
		Hing	
		Salt To Taste	
<p>Method of Preparation: "Step 1: Take a microwave oven safe glass bowl, add all the ingredients other than karela and besan and mix well, select category TC40, enter recipe code & press start. Step 2: When the oven beeps, remove, add the remaining ingredients and mix well and press start. Remove and serve."</p>			

Category	Recipe-	Ingredients:	
TC41	POTATO CURRY	Potatoes, Peeled And Cubed	2 cup
		Tomatoes, Chopped	1½ cup
		Onion, Chopped	1½ cup
		Garlic, Ginger Paste	¾ tsp
		Chili Powder	1½ tsp
		Coriander Powder	1½ tsp
		Cumin Seeds	1½ tsp
		Turmeric Powder	¼ tsp
		Ghee	
<p>Method of Preparation: "Step 1: Take a microwave oven safe bowl, add all the ingredients other than potato and tomatoes. Mix well, select categoryTC41, enter recipe code & press start. Step 2: When the oven beeps, remove, add the all-remaining ingredients, mix well and press start. Remove and serve hot."</p>			

Category	Recipe-	Ingredients:	
TC42	GOAN FISH CURRY	Fish	250 gms
		Fried onion, paste	1½ cup
		Tomato puree	1 cup
		Ginger-Garlic paste	1½ tsp
		Goan fish masala	1½ tsp
		Tamarind paste	½ cup
		Cumin	1 tsp
		Peppercorns	Few
		Cloves	Few
		Red chilies whole	3
		Red chili powder	1 tsp
		Turmeric powder	¼ tsp
		Lemon juice	1 tsp
		Sugar	½ tsp
		Oil as required	
		Salt to taste	
		Chopped coriander for garnishing	
<p>Method of Preparation: "Step 1: Take a microwave oven safe bowl, add all the ingredients other than fish, tomato puree, tamarind paste, lemon juice, coriander leaves, mix well, select category TC42, enter recipe code, & press start.</p> <p>Step 2: When the remove and add the all remaining ingredients oven beeps, other than coriander leaves, mix well and press start. Remove and garnish with coriander leaves. Serve hot."</p>			

Category	Recipe-	Ingredients:	
TC43	ACHARI CHICKEN	Boneless chicken	250 gms
		Fennel seeds	1 tsp
		Chili powder	1 tsp
		Kalonji	1 tsp
		Mustard seeds	½ tsp
		Cumin	1 tsp
		Fenugreek seeds	½ tsp
		Ginger, Garlic paste	1½ tsp
		Turmeric powder	¼ tsp
		Dry red chilies	3
		Vinegar	2 tbsp
		Salt to taste	
<p>Method of Preparation: Step 1: Take a microwave oven safe bowl, add all the ingredients other than vinegar and salt. Mix well, select category TC43, enter recipe code and press start.</p> <p>Step 2: When the oven beeps, remove and add the all remaining ingredients mix well and press start. Remove and serve hot.</p>			

Category	Recipe-	Ingredients:	
TC44	CHICKEN STEW	Chicken (Cut In To Pieces)	2 cups
		Potatoes (Cut In To Pieces)	½ cup
		Carrot Medium (Cut In To Pieces)	½ cup
		Tiny Pearl Onions (Peeled)	½ cup
		French Beans (Cut In To Pieces)	½ cup
		Cauliflower Florets	½ cup
		Garlic (Crushed)	Few
		Corn Flour	¾ cup
		Bay Leaves	Few
		Parsley	1½ tbsp
		Celery Stalk (Lightly Crushed)	1½ tbsp
		Dried Thyme	Few
		Block Pepper Corns (Crushed)	Few
		Salt To Taste	
		Oil As Required	
		Water As Required	

Method of Preparation: "Step 1: Take a microwave oven safe glass bowl, add all the ingredients other than chicken. Mix well and select category TC44, enter recipe code & press start.
Step 2: When the oven beeps, Remove and add remaining ingredients, mix well and press start. Serve hot."

Category	Recipe-	Ingredients:	
TC45	AVIAL	Carrot	½ cup
		Potato	½ cup
		Drumstick	½ cup
		French beans	½ cup
		Bottle gourd	½ cup
		Coconut milk	½ cup
		Curd (beaten)	½ cup
		Curry leaves	Few
		Mustard seeds	1 tsp
		Turmeric powder	¼ tsp
		Salt to taste	
		Oil as required	

Method of Preparation: "Step 1: Take a microwave oven safe glass bowl, add all the ingredients other than coconut milk, curd and mix well and select category TC45, enter recipe code & press start.
Step 2: When the oven beeps, Remove and add remaining ingredients, mix well and Press start. Serve hot."

Category	Recipe-	Ingredients:	
TC46	KADAI CHICKEN	To marinate:	250 gms
		Chicken	1 tsp
		Red chilly powder	½ tsp
		Turmeric powder	1 tsp
		Ginger garlic paste	1 tsp
		Lemon juice	1 tbsp
		Salt to taste	
		To prepare Gravy:	
		Onion	1½ cup
		Tomato	1 cup
		Chopped capsicum	½ cup
		Cardamom	2
		Cloves	3
		Cinnamon	1
		Star anise	1
		Ginger garlic paste	1 tsp
		Coriander powder	½ tsp
		Cumin powder	½ tsp
		Bay leaf	3
		Red chili powder	½ tsp
		Coriander leaves for garnish	2 tbsp
		Salt to taste	
<p>Method of Preparation: "Marinate the chicken with all marinate ingredients for 20 minutes. Step 1: Take a microwave oven safe bowl, add all ingredients other than marinated chicken, tomato, coriander leaves and mix well. Select category TC46, enter recipe code & press start. Step 2: When the oven beeps, remove and add all remaining ingredients other than coriander leaves, mix well & press start. Garnish with coriander leaves. Serve hot."</p>			

Category	Recipe-	Ingredients:	
TC47	SARSON KA SAG	Sarson (Green Mustard) Chopped	2 cup
		Palak Chopped	2 cup
		Onion Chopped	4
		Garlic, Ginger Paste	2 tsp
		Green Chillies (Finely Chopped)	2 tsp
		Makkai Ka Atta (Corn Flour)	2 tbsp
		Powdered Gul (Jaggery)	2 tbsp
		Red Chilli Powder	2 tsp
		Ghee As Required	
		Salt To Taste	
<p>Method of Preparation: "Step 1: Take a microwave oven safe bowl, add all ingredients other than sarson, spinach, corn flour and mix well. Select category TC47, enter recipe code & press start. Step 2: when the oven beeps, remove, add the remaining ingredients, mix well, and press start. Remove, set to cool and grind the mixture to a rough paste and serve hot."</p>			

Category	Recipe-	Ingredients:	
TC48	MUTTON LIVER CURRY	Mutton liver	2½ cup
		Tomato (Chopped)	1 cup
		Red chili powder	2 tsp
		Onions (Chopped)	1 cup
		Black Pepper Powder	½ tsp
		Turmeric Powder	¼ tsp
		Cinnamon	2
		Coriander seeds	2 tsp
		Cumin seeds	1 tsp
		Cloves	4
		Green Cardamoms	5
		Ginger and Garlic Paste.	2 tsp
		Curry Leaves	Few
		Oil as required	
		Salt to taste	
		Coriander Leaves for garnish	
<p>Method of Preparation:"Step 1: Take a microwave oven safe bowl, add all ingredients other than mutton, tomato, coriander leaves and mix well. Select category TC48, enter recipe code & press start. Step 2: When the oven beeps, remove, add the remaining ingredients other than coriander leaves, mix well and press start. Serve hot."</p>			

INDIA'S BEST RECIPES

Category	Recipe-	Ingredients:	
IB1	KASHMIRI PULLAO	Basmati Rice Soaked	1½ cup
		Cinnamon Stick	3
		Shahjeera r	1 tsp
		Tej Patta	3
		Cloves	3
		Cardamoms	Few
		Dry Ginger Powder	4
		Fennel Powder	½ tsp
		Ghee	2 tbsp
		Water As Required	
		Salt As Required	
		For Garnishing Pulao:	
		Onion, Sliced Thinly	1
		Cashews	6
		Almonds	5
		Walnuts	5
		Saffron	pinch of
<p>Method of Preparation:Step 1: In a microwave oven safe bowl add all ingredients other than water, garnish ingredients, mix well. Select Category IB1, enter recipe code and press start.</p> <p>Step 2: When the oven beeps, remove and add water, mix well and press start. Remove and garnishwith onions, cashew, almonds, saffron and Serve hot.</p>			

Category	Recipe-	Ingredients:	
IB2	BISI BELE BATH	Red gram dal	½ cup
		Rice	1 cup
		Brinjal chopped	2
		Tamarind juice	½ cup
		Hing	a pinch
		Oil as required	
		Salt to taste	
		Water as required	
		Paste ingredients	
		Onion	1
		Green chillies	1 tsp
		Cashew nuts	½ cup
		Grated coconut	½ cup
		Khus khus	½ cup
		Curry leaves	Few
		Coriander leaves	½ cup
		Powdered ingredients	
		Dry red chillies	3
		Fenugreek seeds	1 tsp
		Coriander seeds	½ tsp
		Mustard	½ tsp
		Cardamoms	3
		Cinnamon	1
		Cloves	3
		Saunf	1 tsp
<p>Method of Preparation:"Step 1: In a microwave oven safe bowl add oil, add all paste and powder ingredients other than rice, dal, brinjal, water, mix well. Select category IB2, enter recipe code and press start. Step 2: When the oven beeps, remove and add all remaining ingredients, mix well and press start. Serve hot</p>			

Category	Recipe-	Ingredients:	
IB3	VEGETABLE BIRYANI	Rice	1½ cup
		Ghee	1 tbsps
		Carrot Chopped	¼ cup
		French Beans Chopped	¼ cup
		Green Peas	¼ cup
		Red Chilli Powder	½ tsp
		Garam Masala	¾ tsp
		Garlic Paste	¼ tsp
		Ginger Paste	¼ tsp
		Green ChilliesChopped	¼ tbsps
		Onion Chopped	1
		Tomato Chopped	1
		Cinnamon	½ inch
		Cloves	4
		Cardamom	4
		Coconut Milk	1cup
		Cashew Nuts	Few
		Mint Leaves	Few
		Coriander Leaves	Few
		Lemon Juice	½ tsp
		Salt To Taste	
		Water As Required	

Method of Preparation:"Step 1: In a microwave oven safe bowl add all ingredients other than rice, tomato, coconut milk, water, cashew nuts, mint leaves, coriander leaves, lemon juice and salt. Mix well, select category IB3,enter recipe code & press start.

Step 2: When the oven beeps, remove, add the remaining ingredients, mix well and press start. Serve hot."

Category	Recipe-	Ingredients:	
IB4	VEG- PULLAO	Rice (Soaked)	1 cup
		Potato Cut Into Cubes	½ cup
		Carrot Cut Into Cubes	½ cup
		Cauliflower Cut Into Florets	½ cup
		Peas	½ cup
		Cashew Nuts	½ tbsp
		Raisins	1 tsp
		Onions	1
		Ghee	2 tbsp
		Oil	1 tsp
		Turmeric Powder	¼ tsp
		Ginger Paste	¼ tsp
		Garlic Paste	½ tsp
		Green Chilli Paste	½ tsp
		Cinnamon Stick	2
		Cloves	3
		Mint Leaves	¼ tbsp
		Cardamom	3
		Water As Required	
		Salt To Taste	
Method of Preparation:"Step 1: In a microwave oven safe bowl add all ingredients other than rice, water and salt, mix well. Select category IB4, enter recipe code and press start. Step 2: when the oven beeps, remove, add the remaining ingredients, mix well, and press start. Serve hot."			

Category	Recipe-	Ingredients:	
IB5	JEERA RICE	Rice	1½ cup
		Jeera (Cumin Seeds)	2 tsp
		Cashew Nuts	2 tbsp
		Peppercorns	4
		Bay Leafs	2
		Cloves	3
		Cinnamon Sticks	2
		Onions, Sliced	1
		Ghee As Required	
		Salt To Taste	
		Water As Required	
Method of Preparation:"Step 1: In a microwave oven safe bowl add all ingredients other than rice and water. Mix well. Select category IB5, enter recipe code and press start. Step 2: When the oven beeps, remove, add the remaining ingredients, mix well and press start. Serve hot."			

Category	Recipe-	Ingredients:	
IB6	RASAM	Red Gram Dal	1½ cup
		Tomatoes	2
		Garlic Paste	½ tsp
		Garlic Grated	½ tsp
		Ginger Chopped	½ inch
		Green Chillies Chopped	1
		Turmeric Powder	¼ tsp
		Mustard Seeds	½ tsp
		Cumin Seeds	½ tsp
		Dried Red Chillies	2
		Hing	a pinch
		Curry Leaves	Few
		Pepper Powder	½ tsp
		Oil	2 tbsp
		Salt To Taste	
		Water As Required	
		Coriander Leaves For Garnish	
<p>Method of Preparation:"Step 1: In a microwave oven safe bowl add all ingredients other than red gram dal,tomato, water and coriander leaves. Mix well. Select category IB6, enter recipe code and press start.</p> <p>Step 2: When the oven beeps, remove, add the remaining ingredients other than coriander leave and mix well and press start. Remove, garnish with coriander leaves and serve hot."</p>			

Category	Recipe-	Ingredients:	
IB7	SAMBHAR	Red Gram Dal	1½ cup
		Turmeric Powder	¼ tsp
		Bitter Gourd (Sliced Into Long Pieces)	¾ cup
		Brinjal (Sliced Into Long Pieces)	¾ cup
		Drum Stick (Sliced Into Long Pieces)	½ stick
		Ladies Finger (Sliced Into Long Pieces)	3
		Dried Red Chillies	4
		Curry Leaves	Few
		Tamarind	¾ cup
		Hing	¼ tsp
		Red Chilli Powder	1 tsp
		Oil	2 tbsp
		White Gram Dal (Fried)	1 tsp
		Coriander Seeds (Fried)	½ tbsp
		Mustard Seeds (Fried)	½ tsp
		Coriander Leaves For Garnish	
		Mustard Seeds For Tadka	
		Water	
		Salt To Taste	
<p>Method of Preparation:"Make a paste of fried white gram dal, coriander seeds, mustard seeds. Keep it aside. Mash the tamarind in a cup of water and strain. Keep it aside.</p> <p>Step 1: Take a microwave oven safe bowl add all the ingredients other than red gram dal and water. Mix well. Select category IB7, enter recipe code and press start.</p> <p>Step 2: When the oven beeps, remove, add the remaining ingredients, mix well and press start. Serve hot."</p>			

Category	Recipe-	Ingredients:	
IB8	ZAFRANI PULAO	Basmati Rice	1½ cup
		Water	2 cup
		Sugar	3 tbsp
		Milk	1½ cup
		Cashews	¾ cup
		Cardamoms	5
		Cloves	Few
		Almonds, Blanched And Cut	¾ cup
		Saffron Strands, Soaked In Hot Milk	¼ tsp
		Ghee As Required	1½ tsp
Method of Preparation:"Step 1: Take a microwave oven safe bowl, add all ingredients other than water and mix well. Select category IB8, enter recipe code and press start. Step 2:When the oven beeps, remove and add water, mix well and press start. Serve hot."			

Category	Recipe-	Ingredients:	
IB9	DAL TADKA	Red Lentils (Masoor Dal)	1 cup
		Yellow Lentils (Moong Dal)	1 cup
		Tomato Chopped	2
		Onion Chopped	1
		Oil	1 tbsp
		Red Chilli Powder	1 tsp
		Turmeric Powder	¼ tsp
		Ginger Paste	½ tsp
		Garlic Paste	½ tsp
		Green Chillies Chopped	2
		Mustard Seeds	¼ tsp
		Dried Red Chillies	2
		Coriander Leaves For Garnish	
		Salt To Taste	
		Water As Required	
Method of Preparation:"Step 1: In a microwave oven safe bowl add all ingredients other than red lentils, yellow lentils, tomato, water and salt. Mix well. Select category IB9, enter recipe code and press start. Step 2: When the oven beeps, remove, add the remaining ingredients, mix well and press start. Serve hot."			

Category	Recipe-	Ingredients:	
IB10	CHICKEN CHETTINAD	Chicken	200 gms
		Khus Khus Roasted	1 tbsp
		Dry Red Chillies Roasted	3
		Coriander Roasted	½ tsp
		Mustard Roasted	½ tbsp
		Cinnamon Roasted	½ inch
		Cardamom Roasted	2
		Cloves Roasted	2
		Chilli Powder	1 tsp
		Turmeric Powder	½ tsp
		Chopped Ginger	1 tsp
		Chopped Garlic	1 tsp
		Chopped Tomato	1
		Chopped Onions	1
		Oil	1 tbsp
		Curry Leaves	Few
		Lemon Juice	½ tsp
		Sugar	½ tsp
		Grated Coconut for Garnish	
		Coriander Leaves for Garnish	
		Salt To Taste	

Method of Preparation:"In a mixer, grind all the roasted ingredients with garlic and ginger to make a uniform paste.

Step 1: Take a microwave oven safe bowl add all the ingredients other than chicken, tomato, coconut and coriander leaves. Mix well. Select category IB10, enter recipe code and press start.

Step 2: When the oven beeps, remove, add the remaining ingredients except coconut and coriander leaves, mix well and press start. Remove, garnish with coconut and coriander. Serve hot."

Category	Recipe-	Ingredients:	
IB11	FISH CURRY	Fish - Washed & Sliced	250 gms
		Coriander Leaves – Chopped	1½ tbsp
		Tomatoes - Finely Chopped	2
		Garlic Cloves	6
		Green Chillies – Chopped	3
		Methi Seeds	1½ tsp
		Coriander Powder	1½ tsp
		Turmeric Powder	½ tsp
		Salt To Taste	
		Oil As Required	
		Water As Required	
		Oil As Required	

Method of Preparation:"Marinate the fish in salt and turmeric powder for 15 minutes. Grind the coriander leaves, methi seeds, garlic and green chillies into a paste.

Step 1: Take a microwave oven safe bowl, add all the ingredients other than the fish and above paste. Mix well, select category IB11, enter recipe code & press start.

Step 2: When the oven beeps, remove and add fish & coriander, methi seeds, green chili, garlic paste to the tadka and mix smoothly and press start. Remove and serve hot."

Category	Recipe-	Ingredients:	
IB12	TOMATO RASAM	Red Gram Dal	3 tbsp
		Tomatoes	5
		Garlic Paste	2 tsp
		Garlic Grated	2 tsp
		Ginger Chopped	1 inch
		Green Chillies Chopped	3
		Turmeric Powder	¾ tsp
		Mustard Seeds	1½ tsp
		Cumin Seeds	1½ tsp
		Dried Red Chillies	4
		Hing	a pinch
		Curry Leaves	Few
		Pepper Powder	2 tsp
		Oil	2 tbsp
		Salt To Taste	
		Water	
		Coriander Leaves For Garnish	
<p>Method of Preparation:"Step 1:In a microwave oven safe bowl, add all ingredients other than tomatoes, water,coriander, mix well. Place in the microwave, select category IB12,enter recipe code & press start.</p> <p>Step 2: After the beep, remove & add remaining ingredients other than coriander leaves, mix well and press start. Remove and garnished with coriander leaves. Serve hot</p>			

Category	Recipe-	Ingredients:	
IB13	PANEER MASALA	Paneer (Cut Into Cubes)	250 gms
		Tomatoes (Chopped)	1 cup
		Oil	1½ tbsp
		Green Chilli	4
		Cumin Seeds	1 tsp
		Garlic Ginger Paste	1 tsp
		Cloves	4
		Turmeric Powder	¾ tsp
		Red Chilli Powder	2 tsp
		Pepper Powder	1 tsp
		Cardamom Powder	1 tsp
		Salt To Taste	
		Water As Required	
		Coriander Leaves For Garnish	
<p>Method of Preparation:"Step 1: Take a microwave oven safe bowl, add all ingredients other than paneer, water and coriander leaves. Mix well, select category IB13, enter recipe code & press start.</p> <p>Step 2: When the oven beeps, remove and add paneer and water and mix well and press start. Remove, garnish with coriander and serve."</p>			

Category	Recipe-	Ingredients:	
IB14	LEAFY VEGETABLE	Spinach Leaves, Washed & Chopped	2 cup
		Mustard Greens, Washed & Chopped	2 cup
		Cumin Seeds	1 tsp
		Green Chilli (Minced)	1 tsp
		Ginger Paste	1 tsp
		Garlic Paste	1 tsp
		Turmeric Powder	½ tsp
		Red Chilli Powder	
		Hing A Pinch	
		Oil As Required	
		Salt To Taste	

Method of Preparation:"Step 1: Take a microwave oven safe bowl; add all ingredients other than spinach leaves and mustard greens. Mix well, select category IB14,enter recipe code and press start.
Step 2: When the oven beeps, remove and add the remaining ingredients, mix well. Cover the bowl with lid, place it in the microwave oven and press start. Serve hot."

Category	Recipe-	Ingredients:	
IB15	TOMATO CURRY	Tomatoes (Chopped)	250 gms
		Finely Chopped Onion	3
		Red Chilly Powder	1½ tsp
		Cumins	1 tsp
		Turmeric Powder	½ tsp
		Garam Masala	1½ tsp
		Garlic Crushed	4
		Curry Leaves	Few
		Oil As Required	
		Salt To Taste	

Method of Preparation:"Step 1: Take a microwave oven safe bowl, add all ingredients other than tomato and garam masala. Mix well. Select category IB15, enter recipe code & press start.
Step 2: When the oven beeps, remove and add the remaining ingredients and mix well. Cover the bowl with lid, place it in the microwave oven and press start. Remove and serve hot."

Category	Recipe-	Ingredients:	
IB16	PRAWNS CURRY	Prawn – Shelled	250 gms
		Onions Cut Into Small Pieces	3
		Garlic Paste	1½ tsp
		Ginger Paste	1½ tsp
		Chilli Powder	1 tsp
		Turmeric Powder	½ tsp
		Mustard Seeds	½ tsp
		Oil	1 tbsp
		Salt To Taste	

Method of Preparation:"Step 1: Take a microwave oven safe bowl, add all ingredients other than the prawns. Mix well, select category IB16, enter recipe code & press start.
Step 2: When the oven beeps, remove and add the prawns and mix well. Place the bowl in the microwave oven and press start. Remove, and serve."

Category	Recipe-	Ingredients:	
IB17	PALAK PANEER	Paneer	250 gms
		Palak Paste	3 cup
		Onion Paste	2 cup
		Black Pepper Powder	½ tsp
		Ginger-Garlic Paste	1 tsp
		Green Chilli Paste	1 tsp
		Bay Leaves	3
		Cumin Seeds	1 tsp
		Garam Masala Powder	1 tsp
		Butter As Required	
		Salt To Taste	
<p>Method of Preparation:"Step 1: Take a microwave oven safe bowl, add all ingredients other than paneer, spinach paste, and salt. Mix well, select category IB17, enter recipe code & press start. Step 2: When the oven beeps, remove and add the remaining ingredients, mix well and press start. Serve hot."</p>			

Category	Recipe-	Ingredients:	
IB18	BHENDI FRY	Lady Finger (Okra / Bhendi)	250 gms
		Gram Flour	1 cup
		Sliced Onion	1 cup
		Sliced Green Chilli	3
		Coriander Powder	1 tsp
		Red Chilli Powder	1½ tsp
		Garam Masala Powder	1½ tsp
		Cumin Seeds	1 tsp
		Turmeric Powder	¼ tsp
		Oil As Required	
		Salt To Taste	
<p>Method of Preparation:Step 1: Take a microwave oven safe bowl, add all ingredients other than lady finger. Mix well, select category IB18, enter recipe code & press start. Step 2: When the oven beeps, remove and add lady fingers, mix well and press start. Remove and serve hot.</p>			

Category	Recipe-	Ingredients:	
IB19	ALOO MATAR	Potatoes	2 cup
		Green Peas	1½ cup
		Curd	1½ cup
		Green Chillies	2
		Turmeric Powder	¼ tsp
		Onion	2
		Tomatoes Puree	1½ cup
		Ginger	½ tsp
		Coriander Powder	½ tsp
		Red Chilli Powder	1 tsp
		Garam Masala	1 tsp
		Oil As Required	
<p>Method of Preparation:"Step 1: Take a microwave oven safe bowl, add all ingredients other than tomato puree, salt, green peas, coriander leaves and curd. Mix well, select category IB19, enter recipe code, press start. Step 2: When the oven beeps, remove and add all remaining ingredients other than coriander leaves, mix well and press start. Remove, garnish with coriander leaves and serve."</p>			

Category	Recipe-	Ingredients:	
IB20	KADAI PANEER	Paneer	2 cup
		Tomatoes Chopped	1 cup
		Capsicums	1 cup
		Onions Cubed	2 cup
		Ginger Garlic Paste	2 tsp
		Turmeric Powder	½ tsp
		Coriander Seeds	1 tsp
		Red Chillies	Few
		Garam Masala	2 tsp
		Kasoori Methi	1 tsp
		Coriander Leaves Chopped	3 tbsp
		Cream	3 tbsp
		Salt To Taste	
		Oil As Needed	
<p>Method of Preparation:"Step 1: Take a microwave oven safe bowl, add all ingredients other than paneer, capsicum, tomato, coriander leaves, creame and mix well and select category IB20, enter recipe code & press start. Step 2: When the oven beeps, remove and add all remaining ingredients, mix well and press start. Serve hot."</p>			

Category	Recipe-	Ingredients:	
IB21	SOYABEAN MASALA	Soya beans	1 cup
		Onions (chopped)	1 cup
		Tomato (chopped)	¾ cup
		Ginger paste	½ tsp
		Garlic paste	½ tsp
		Chilli powder	1 tsp
		Coriander powder	1 tsp
		Turmeric powder	¼ tsp
		Curry leaves	Few
		Cloves	Few
		Cinnamon	2
		Thick coconut milk	½ cup
		Salt - As reqd	
		Oil as required	
		Water as required	
<p>Method of Preparation:"Step 1: Take a microwave oven safe bowl, add all ingredients other than soya beans, tomato, milk, water and mix well. Select category IB21, enter recipe code & press start. Step 2: When the oven beeps, remove and add all remaining ingredients, mix well and press start. Serve hot."</p>			

Category	Recipe-	Ingredients:	
IB22	PANEER MATAR	Paneer	2 cup
		Matar	1 cup
		Chopped Tomatoes	¾ cup
		Chopped Onions	1 cup
		Cumin Seeds	1 tsp
		Turmeric Powder	¼ tsp
		Red Chili Powder	1 tsp
		Garam Masala	1 tsp
		Ginger Paste	½ tsp
		Garlic Paste	½ tsp
		Oil Or Ghee	
		Coriander Leaves For Garnishing	
		Salt As Required	
		Water As Required	
<p>Method of Preparation:Step 1: Take a microwave oven safe bowl, add all ingredients other than paneer, tomato, coriander, water and mixwell. Select category IB22, enter recipe code and press start. Step 2: When the oven beeps, remove and add all the remaining ingredients other than coriander leaves, mix well and press start. Remove garnish with coriander leaves, Serve hot.</p>			

Category	Recipe-	Ingredients:	
IB23	GARLIC GINGER PRAWNS	Prawns, Peeled	300 gr
		Onion Chopped	1 cup
		Tomato Chopped	¼ cup
		Garlic	2 tsp
		Ginger, Grated Finely	3 tsp
		Soy Sauce	3 tsp
		Corn Flour	½ cup
		Chicken Stock	1 cup
		Rice To Serve	
		Oil As Required	
<p>Method of Preparation: Step 1: Take a microwave oven safe bowl. Add all ingredients other than prawns, tomato, soya sauce, chickenstock, rice and mix well. Select category IB23, enter recipe code & press start. Step 2: When the oven beeps, remove and add all remaining ingredients other than rice, mix well and press start. Remove and serve with rice.</p>			

Category	Recipe-	Ingredients:	
IB24	PLAIN PALAK CURRY	Palak (Spinach) Finely Chopped	2½ cup
		Red Chilly Powder	1 tsp
		Moong Dal	½ cup
		Garam Masala	1 tsp
		Turmeric Powder	¼ tsp
		Onion	¼ tsp
		Garlic Paste	¼ tsp
		Ginger Paste	¼ tsp
		Oil As Required	
		Salt To Taste	
<p>Method of Preparation: "Step 1: Take a microwave oven safe bowl, add all ingredients other than palak and salt. Mix well, select category IB24, enter recipe code & press start. Step 2: When the oven beeps, remove and add the remaining ingredients, mix well and press start. Remove and serve hot."</p>			

Category	Recipe-	Ingredients:	
IB25	FISH PULUSU	Fish	300 gr
		Chopped Onions	¾ cup
		Green Chillies Slit	3
		Ginger Garlic Paste	1½ tsp
		Slightly Roasted Poppy Seeds	¾ tsp
		Grated Coconut	¾ cup
		Garam Masala	1½ tsp
		Red Chili Powder	1½ tsp
		Lemon Juice	1½ tsp
		Turmeric Powder	¼ tsp
		Red Chili Powder	1½ tsp
		Fresh Coriander Leaves	2½ tbsp
		Bay Leaf	Few
		Cloves	4
		Cinnamon Stick	3
		Cumin	¾ tsp
		Green Cardamom	3
		Tamarind Juice	¾ cup
		Curry Leaves	Few
		Oil As Required	
		Salt As Needed	

Method of Preparation: Step 1: Take a microwave oven safe bowl, add all ingredients other than fish, lemon juice, tamarind juice and mixwell. Select category IB25, enter recipe code & press start.

Step 2: When the oven beeps, remove and add all remaining ingredients, mix well and press start. Serve hot.

Category	Recipe-	Ingredients:	
IB26	CHILLI CHICKEN	Boneless Chicken	300 gr
		Chilli Sauce	1½ tsp
		Soya Sauce	1½ tsp
		Pepper Powder	1½ tsp
		Vinegar	1½ tsp
		Corn Flour	1½ tbsp
		Red Chili Powder	1½ tsp
		Eggs	3
		Salt To Taste	
		Seasoning :-	
		Soya Sauce	¾ tsp
		Chilli Sauce	¾ tsp
		Red Chilli Powder	¾ tsp
		Sugar	¾ tsp
		Veggies :-	
		Onion Thinly Sliced	¾ cup
		Garlic Chopped	¾ tsp
		Capsicum	¾ cup
		Green Chilies Slit And Deseeded	¾ tsp
		Celery Chopped Finely (Optional)	½ cup
		Spring Onions For Garnish	
<p>Method of Preparation:Step 1: Take a microwave oven safe bowl, Add chicken and mix well. Select category IB26,enter recipe code and press start to cook. After the oven beeps, remove and add all ingredients other than seasoning and veggies mix well and set it aside for 20 minutes for marination.</p> <p>Step 2: When the oven beeps, remove and add seasonings, veggies, mix well and press start to cook. Garnish with spring onions, Serve hot.</p>			

Category	Recipe-	Ingredients:	
IB27	METHI CURRY	Methi , finely chopped	300 gr
		Gram flour	3 tbsp
		Onion chopped	1 cup
		Tomato chopped	1 cup
		Garlic, minced	Few
		Garlic, minced	1 tsp
		Turmeric powder	¼ tsp
		Red chilli powder	1 tsp
		Salt To Taste	
		Lemon juice	1 tsp
		Oil as required	
<p>Method of Preparation:Step 1: Take a microwave oven safe bowl, add all ingredients other than methi, tomato, lemon juice and mix well.Select category IB27, enter recipe code & press start.</p> <p>Step 2: When the oven beeps, remove and add all remaining ingredients, mix well and press start. Serve hot.</p>			

Category	Recipe-	Ingredients:	
IB28	HAKKA NOODLES	Boiled Noodles	1½ cup
		Spring Onions	1½ tbsp
		Carrot Chopped	¼ cup
		Garlic Chopped	½ tsp
		Capsicum Chopped	1½ tbsp
		Pepper Powder	½ tsp
		Chili Sauce	1½ tsp
		Soya Sauce	1½ tsp
		White Vinegar	1½ tsp
		Beans Chopped (Optional)	¼ cup
		Finely Shredded Cabbage (Optional)	¼ cup
		Mushrooms Chopped (Optional)	¼ cup
		Salt To Taste	
		Oil As Required	

Method of Preparation:

"Step 1: Take a microwave oven safe bowl, add all the ingredients other than noodles. Mix well, Select category IB28, enter recipe code & press start.

Step 2: When the oven beeps, remove and add noodles. mix well and press start. Serve hot."

Category	Recipe-	Ingredients:	
IB29	PANEER MAKHANI	Paneer	300 gms
		Tomato Puree	1½ cup
		Fresh Cream	1½ cup
		Green Chillies	2
		Red Chilli Powder	1 tsp
		Garam Masala Powder	1 tsp
		Dried Kasuri Methi	Few
		Butter As Required	
		Salt To Taste	

Method of Preparation: Step 1: Take a microwave oven safe bowl, add all ingredients other than tomato puree and fresh cream. Mix well, select category IB29, enter recipe code & press start.

Step 2: After the oven beeps, remove, add the remaining ingredients, mix well and press start. Remove, and serve hot.

Category	Recipe-	Ingredients:	
IB30	STUFFED KHANDVI	Besan	2 cup
		Butter Milk	4 cup
		Turmeric Powder	½ tsp
		Grated Carrot	1 cup
		Oil	¾ tbsp
		Sesame Seeds	2 tsp
		Mustard Seeds	¾ tsp
		Coconut Scraped	¾ tbsp
		Chopped Coriander	¾ tbsp
		Hing	a pinch
		Chopped Green Chillies	3
		Salt To Taste	

Method of Preparation:

"Step 1: Take butter milk in a microwave oven safe bowl, add besan, turmeric powder, oil, salt, sesame seeds, mustard, hing, coconut, coriander, green chillies & mix well to avoid lump formation. Place the bowl on the turntable in the microwave oven, select category IB30, enter recipe code & press start.

Step 2: When the oven beeps, remove, stir well and press start. When done, pour a cup full in a large flat plate. Spread as thin as possible with the back of a large flat spoon using circular outward movements. Allow to cool & stuff with grated carrot cut into 1½-inch wide strips. Carefully roll each strip & Serve with chutney."

Category	Recipe-	Ingredients:	
IB31	VEG BIRYANI	Rice	1½ cup
		Ghee	2 tbsp
		Carrot Chopped	¼ cup
		French Beans Chopped	¼ cup
		Green Peas	¼ cup
		Red Chilli Powder	½ tsp
		Garam Masala	¾ tsp
		Garlic Paste	¾ tsp
		Ginger Paste	¾ tsp
		Green Chillies Chopped	¼ tbsp
		Onion Chopped	1
		Tomato Chopped	1
		Cinnamon	½ inch
		Cloves	4
		Cardamom	4
		Coconut Milk	1cup
		Cashew Nuts	Few
		Mint Leaves	Few
		Coriander Leaves	Few
		Lemon Juice	½ tsp
		Salt To Taste	
		Water As Required	

Method of Preparation: Step 1: Take a microwave oven safe bowl; add all the ingredients other than rice, tomato, coconut milk, water, cashew nuts, mint leaves, coriander leaves, lemon juice and salt and mix well. Select category IB31, enter recipe code and press start.

Step 2: When the oven beeps, remove and add the remaining ingredients other than coconut milk, cashew nuts, lemon juice, mix well and press start.

Step 3: After the oven beeps. Remove, and all remaining ingredients, mix well and press start. Serve hot.

Category	Recipe-	Ingredients:	
IB32	CHICKEN BIRYANI	Basmati rice (half cooked)	1½ cup
		Boneless chicken	3 cup
		Curd	1½ cup
		Tomato puree	3 tbsps
		Ginger garlic paste	1 tsp
		Garam masala	1 tsp
		Red chilli powder	1 tsp
		Onion paste	1½ cup
		Coriander leaves	Few
		Coriander powder	1 tsp
		Turmeric powder	¼ tsp
		Water as required	
		Salt to taste	
		Oil as required	

Method of Preparation: Step 1: Take a microwave oven safe bowl, add all ingredients other than rice, chicken, curd, tomato, water and mix well. Select category IB32, enter recipe code & press start.

Step 2: When the oven beeps, remove and add chicken, curd, tomato, mix well & press start.

Step 3: When the oven beeps, remove and add half cooked rice, water, mix well and press start. Serve hot.

Category	Recipe-	Ingredients:	
IB33	VEN PONGAL	Rice (soaked)	1 cup
		Moong dal (soaked)	1 cup
		Cumin seeds	1 tsp
		Pepper powder	1 tsp
		Cashewnuts	Few
		Ghee	3 tbsps
		Water as required	
		Salt to taste	

Method of Preparation: Step 1: Take a microwave oven safe bowl, add all ingredients other than rice, water and mix well. Select category IB33, enter recipe code & press start.

Step 2: When the oven beeps, remove and add rice, water, mix well & press start. Step 3: When the oven beeps, remove, mix well and press start. Serve hot.

Category	Recipe-	Ingredients:	
IB34	BENGALI BIRYANI	Basmati rice (half cooked)	1½ cup
		Fish (Hilsa)	250 g
		Ghee	2 tbsp
		Onion (sliced)	2 nos.
		Ginger-garlic paste	2 tsp
		Red chilli powder	1 tsp
		Cumin powder	1 tsp
		Black pepper	Few
		Bay leaf	3
		Cloves	Few
		Turmeric powder	¼ tsp
		Garam masala	1 tsp
		Cardamom	3
		Cinnamon	2
		Curd	1 cup
		Oil as required	
		Water as required	
		Salt to taste	
<p>Method of Preparation: Step 1: Take a microwave oven safe bowl, add all ingredients other than rice, fish, curd, water and mix well. Select category IB34, enter recipe code & press start.</p> <p>Step 2: When the oven beeps, remove and add chicken, curd, mix well & press start.</p> <p>Step 3: When the oven beeps, remove and add half-cooked rice, water, mix well and press start. Wait for 3 minutes. Serve hot</p>			

Category	Recipe-	Ingredients:	
IB35	CURD RICE	Rice	1½ cup
		Dahi / Yogurt	1½ cup
		Milk	1 cup
		Mustard Seeds	½ tsp
		Cumins Seeds	½ tsp
		Dry Red Chilly (Cut Into Small)	2
		Ghee	1 tbsp
		Medium Size Cucumber Grated	½
		Seedless Grapes (Chopped)	50 gms
		Pomegranate (Dalim) Seeds	¼ tsp
		Water As Required	
		Salt To Taste	
<p>Method of Preparation: "Step 1: Take a microwave oven safe bowl, add all ingredients other than rice, yogurt, milk, cucumber, grapes, dalim and water. Mix well. Select category IB35, enter recipe code & press start.</p> <p>Step 2: When the oven beeps, remove and add the remaining ingredients other than grapes, dalim, mix well and press start. Remove, add grapes, dalim and serve hot."</p>			

Category	Recipe-	Ingredients:	
IB36	VEG SANDWICH	Bread slices	6
		Chopped onion	1 cup
		Chopped tomato	1 cup
		Chopped capsicum	1 cup
		Grated cheese	4 tbsp
		Pepper	½ tsp
		Butter	4 tbsp
		Sauce / spread	4 tbsp
		Salt To Taste	

Method of Preparation:

"On a bread slice apply butter, layer with sauce, spread chopped vegetables, sprinkle grated cheese. Cover it with the other bread slice.

Step 1: Keep the sandwich on high rack. Select category IB36, enter recipe code and press start.

Step 2: When the oven beeps, change the side of the sandwich & again press start."

Category	Recipe-	Ingredients:	
IB37	BAKED POTATO CHEESEBALLS	Potatoes, boiled& smashed	250 gr
		Breadcrumbs	1½ cup
		Cheese grated	½ cup
		Pepper powder	½ cup
		Mint powdered	½ cup
		Salt to taste	
		Ghee	

Method of Preparation:"Combine all ingredients to make small potato cheese balls.

Step 1: Keep the potato cheese balls in the crispy plate, on the high mesh rack. Select category IB37, enter recipe code and press start.

Step 2: When the oven beeps, change the side of the sandwich & again press start."

Category	Recipe-	Ingredients:	
IB38	CHEESE TOAST	Bread slices	6
		Butter as required	
		For Filling	
		Boiled cabbage	¼ cup
		Boiled Cauliflower	¼ cup
		Boiled Capsicum	¼ cup
		Chopped onions	¼ cup
		Mashed boiled potatoes	¼ cup
		Chopped green chillies	1 tsp
		Red chilli powder	1 tsp
		Grated cheese	1 cup
		Green peas	¼ cup
		French beans	¼ cup
		Garam masala	1 tsp
		Chopped coriander leaves	3 tbsp
		Salt to taste	

Method of Preparation:

"In a bowl add mashed boiled potatoes, boiled vegetables, Mash them well. Add chopped onion, green chillies & hopped coriander leaves. Mix well. Now add salt, red chilli powder, garam masala. Mix well. Apply butter on one side of all bread slices. Put the filling & grated cheese on one slice & cover with other slice. Prepare all the toasts in same way.

Step 1: Keep the toasts on the high rack. Select category IB38, enter recipe code and press start.

Step 2: When the oven beeps, turn over the side & press start."

Category	Recipe-	Ingredients:	300 gr
IB39	SURAN TIKKI	Boiled Suran	300 gms
		Green Peas Cooked	1½ cup
		Black Pepper Powder	¼ tsp
		Ginger Paste	1½ tsp
		Garam Masala	1½ tsp
		Red Chili Powder	1½ tsp
		Cumins Powder	1½ tsp
		Oil As Required	
		Salt to taste	

Method of Preparation:

Mash suran and green peas together. Add all the remaining ingredients, mix well and shape them as medium sized tikkies. Arrange tikki in a lightly greased crusty plate and place the crusty plate on the mesh rack in the microwave oven. Select category IB39, enter recipe code and press start. Turn once in between. -

Category	Recipe-	Ingredients:	
IB40	GUAJRATHI HANDVA	Toovar Dal, Soaked	½ cup
		Urad Dal, Soaked	¼ cup
		Moong Dal, Soaked	¼ cup
		Chana Dal, Soaked	¼ cup
		Rice, Soaked	½ cup
		Curd	½ cup
		Lauki, Grated	1 cup
		Oil	2 tbsp
		Lemon Juice	1 tsp
		Soda	pinch of
		Sugar	1 tsp
		Chilli Powder	1 tsp
		Turmeric Powder (Haldi)	¼ tsp
		Ginger-Green Chilli Paste	2 tsp
		Salt To Taste	
		Mustard Seeds	½ tsp
		Sesame Seeds	1 tsp
		Ajwain	½ tsp
		Hing	pinch of
<p>Method of Preparation: "Blend the dals, rice in a mixer to a smooth mixture. Transfer the mixture to a bowl, add the curds and mix well. Cover and keep aside to ferment overnight. Add all other ingredients, mix well and set aside for 20 minutes. Pour the mixture in a lightly greased baking dish. Step 1: Place the baking dish in on the turntable, select category IB40, enter recipe code,</p>			

Category	Recipe-	Ingredients:	
IB41	BAINGAN KA BARTA	Large Seedless Oval Eggplant	1
		Large Onion Grated	½ tsp
		Ginger Finely Chopped	½ tsp
		Garlic Finely Chopped	2
		Green Chillies Finely Chopped	1 tbsp
		Coriander Leaves Finely Chopped	¼ tsp
		Garam Masala	½ tsp
		Red Chilli Powder	¼ tsp
		Turmeric powder	1 pinch
		Asafetida (Hing)	1 tsp
		Lemon Juice	¼ tsp
		Cumin	¼ tsp
		Mustard Seeds	1 tbsp
		Oil	
		Water	
		Salt To Taste	
<p>Method of Preparation:Step 1: Place the eggplant (pierced on all sides with a fork) on the turn table in the microwave oven. Select category IB41, enter recipe code & press start. Step 2: Remove After the beep, mash eggplant till soft and add all remaining ingredients, mix well, cover bowl with lid and press start. Step 3: After the beep, remove, mix well and press start. Serve hot</p>			

Category	Recipe-	Ingredients:	
IB42	BREAD BHURJI	Bread Slices, cut in to cubes	2 cup
		Onion, chopped	1½ cup
		Green Chilli, chopped	1 tsp
		Turmeric Powder	¼ tsp
		Cumins	1tsp
		Chopped tomato	½ cup
		Garlic paste	1 tsp
		Red chilli powder	1 tsp
		Garam masala	1 tsp
		Oil as required	
		Salt to taste	

Method of Preparation:

Step 1: Take a microwave oven safe bowl, add all ingredients other than bread slices, mix well and select category IB42, enter recipe code & press start.

Step 2: Remove After the beep, add bread slices, mix well and press start.

Step3: After the beep, remove, mix well and press start. Serve hot.

Category	Recipe-	Ingredients:	
IB43	MANCHURIAN SAUCE	Water	1½ cup
		Vinegar sauce	1 tbsp
		Soya sauce	1 tsp
		Tomato sauce	½ cup
		Ajinomoto	A pinch
		Corn flour	2 tbsp + ½ cup water

Method of Preparation: Step 1: Take a microwave oven safe bowl add all the ingredients and mix well. Select category IB43, enter recipe code & press start.

Category	Recipe-	Ingredients:	
IB44	DOKHLA	Besan (Gram Flour)	2 cup
		Corn Flour	2 tsp
		Sugar	1½ tsp
		Turmeric Powder	½ tsp
		Citric Acid	1 tsp
		Soda-Bi-Carb	½ tsp
		Lemon Juice	2 tsp
		Mustard Seeds	¾ tbsp
		Green Chillies - Finely Chopped	2 tsp
		Amchoor Powder	½ tsp
		Salt To Taste	
		Oil As Required	
		Grated Coconut For Garnish	
		Coriander Leaves For Garnish	
		Water As Required	

Method of Preparation:

"Take gram flour, curd, water, salt, mix well into a batter. Cover it and set aside for 4 hours to marinate. Add green chillies, ginger paste, turmeric, lime juice, oil, soda-bi-carb and mix into a smooth batter. Step 1: Pour into microwave oven safe lightly greased bowl, place in the microwave oven, select category IB44, enter recipe code and press start. For tampering use curry leaves, mustard seeds, oil, and green chillies. Garnish with coriander leaves and grated coconut. Serve with chutney."

Category	Recipe-	Ingredients:	
IB45	CHOCOLATE MUFFINS	Maida	1 cup
		Cocoa Powder	¼ cup
		Caster Sugar	½ tsp
		Dark Choc Bits	¼ cup
		Oil	2 tbsp
		Cup Milk	¼ cup
		Vanilla Extract	¼ tsp
		Eggs	1

Method of Preparation:

"Step 1: Take a mixing bowl, add all ingredients to make a smooth batter, mix well and pour the batter in muffin tins and place the muffin tins in the microwave oven, select category IB45, enter recipe code & press start. Remove and serve hot."

Category	Recipe-	Ingredients:	
IB46	CHOCOLATE BALLS	Milkmaid	1 cup
		Marie biscuit powder	1 cup
		Milk powder	½ cup
		Bournvita	½ cup
		Grated coconut	½ cup

Method of Preparation:

Step 1: In a microwave oven safe glass bowl add milkmaid, marie biscuit powder, milk powder, Bournvita. Mix well. Select category IB46, enter recipe code & press start. Allow to cool. Make balls out of the mixture. Roll out the balls in the grated coconut. Keep in refrigerator for half an hour.

Category	Recipe-	Ingredients:	
IB47	CHEESY NACHOS	Nachos	250 g
		Grated cheese	1 cup
		Pizza sauce	6 tbsp
		Chopped onion, tomato	2 cups
Method of Preparation: Step 1: In a microwave oven safe flatadd nachos, chopped onion, tomato, pizza sauceglass dish; & gratedcheese. Select category IB47, enter recipe code & press start			

Category	Recipe-	Ingredients:	
IB48	BANANA HALWA	Banana Ground To Paste	2½ cup
		Wheat Flour	1 cup
		Milk	1 cup
		Cardamom Powder	a pinch
		Sugar	1½ cup
		Cashews	Few
		Almonds	Few
		Ghee As Required	
Method of Preparation:"Step 1: Take a microwave oven safe glass bowl, add ghee and wheat flour, mix them well and select category IB48, enter recipe code & press start. Step 2: After the beep, remove, add the remaining ingredients, mix well and press start. Serve hot." Step 2: When it gives a beep, remove and add all remaining ingredients, mix well and press start. Set to cool. Mix well and store it in a fridge.			

Category	Recipe-	Ingredients:	
IB49	COCONUT LADOO	Suji / Rava	2 cup
		Grated Coconut	3 cup
		Condensed Milk	as required
		Powdered Sugar	2 cup
		Dry Coconut Powder	¾ cup
Method of Preparation:"Step 1: Take suji (rava) in a microwave oven safe glass bowl, Place in the microwave oven, select category IB49, enter recipe code & press start. Step 2: After the beep, remove, add grated coconut, condensed milk, powdered sugar & mix well and press start. Remove After the beep & set aside to cool. Make small balls of the mixture. Roll the balls in dry coconut powder & serve."			

Category	Recipe-	Ingredients:	
IB50	SUKHDI	Whole Wheat Flour	2 cup
		Ghee	1½ cup
		Jaggery - Sliced Thinly	1½ cup
		Milk	1 cup
Method of Preparation:"Step 1: Take a microwave oven safe glass bowl; add wheat flour and ghee mix well. To roast the wheat flour, select category IB50, enter recipe code & press start. Step 2: After the beep, remove and add jaggery, milk, mix well and press start. Serve hot."			

Category	Recipe-	Ingredients:	
IB51	BESAN KA LADOO	Besan	2 cup
		Sugar Powder	1 cup
		Elaichi Powder	¼ tsp
		Ghee (If Needed)	1½ tbsp
		Roasted Cashews Chopped	¼ cup
		Raisins (Optional)	1½ tbsp
Method of Preparation:"Step 1: Take a microwave oven safe glass bowl. Add ghee, besan, mix them well and select category IB51, enter recipe code and press start. (stir twice in between). Step 2: After the beep, remove and add sugar, cardamom, add the ghee if needed, mix well and press start. Step 3: After the beep, remove and add cashew, raisins. Take small portions and roll to balls. Serve warm."			

Category	Recipe-	Ingredients:	
IB52	KAJU KATLI	Roasted Cashew Nuts Powder	1½ cup
		Sugar	¾ cup
		Rose Water	¼ tsp
		Cardamom Powder	¼ tsp
		Water As Required	
Method of Preparation:"Step 1: Take a microwave oven safe bowl, Add sugar, cardamom powder and rose water, mix well and select category IB52, enter recipe code & press start. Step 2: When the sugar melts off completely add the cashew nuts powder into it. Mix well and press start. After the beep, remove, mix well and blend the sugar syrup and powder. The mixture must be smooth. Pour the mixture in to a lightly greased baking dish. Set to cool and cut to it into desired shapes."			

Category	Recipe-	Ingredients:	
IB53	RAGI KHEER	Ghee	1 tbsp
		Ragi Flour	2 tbsp
		Hot Milk	2 cup
		Sugar	1 cup
		Cashews	6
		Pistachios - Chopped Finely	4
		Almonds - Chopped Finely	3
		Saffron – Optional	6 strands
		Cardamom Powder	⅛ tsp
Method of Preparation:"Step 1: Take a microwave oven safe bowl, Add sugar, milk, mix well and select category IB53, enter recipe code & press start. Step 2: When the oven beeps, remove and add ragi flour, ghee, mix well and press start. After the beep, remove, mix them well and add all remaining ingredients and serve hot."			

Category	Recipe-	Ingredients:	
IB54	RICE KHEER	Rice	2 cup
		Milk	4 cup
		Cardamom Seeds	Few
		Almonds	Few
		Saffron Threads, Soaked	a pinch
		Pistachio Nuts	Few
		Raisins (Optional)	Few
		Sugar	1 cup
		Water As Required	

Method of Preparation:

Step 1: Take a microwave oven safe bowl, add all the ingredients other than cardamom, almonds, saffron, pistachio and raisins mix well. Place the bowl in the microwave oven, select category IB54, enter recipe code, and press start.

Step 2: When the oven beeps, remove and add cardamom, almonds, mix well and press start. After the beep remove and add all remaining ingredients, mix well and serve hot.

Category	Recipe-	Ingredients:	
IB55	BADAM HALWA	Almonds (Soaked & Peeled)	1½ cup
		Sugar	1 cup
		Ghee	1½ tbsp
		Cardamom Powder	¼ tsp
		Milk As Required	
		Few Drops Of Rose Water (Optional)	
		Pinch Of Saffron (Optional)	

Method of Preparation:

"Blend badam, sugar, cardamoms, saffron with milk to a smooth paste.

Step 1: Take a microwave oven safe bowl. Add ghee, add the ground paste, rose water. Select category IB55, enter recipe code & press start. Serve hot."

Category	Recipe-	Ingredients:	
IB56	APPLE PIE	Apples cut into slices	4 cup
		Corn starch	3 tbsp
		Honey	3 tbsp
		Raisins (optional)	3 tbsp
		Nutmeg to taste	
		Cinnamon to taste	
		Butter as required	

Method of Preparation:"Marinate the apples with the all ingredients for ½ hour.

Step 1: Arrange the marinate apples in a lightly greased baking dish and place the baking dish on the mesh rack in the microwave oven. Select category IB56,enter recipe code and press start. Turn once in between." -

Category	Recipe-	Ingredients:	
IB57	CARAMEL PUDDING	Milk	4 cup
		Sugar	2 cup
		Eggs	4
		Vanilla extract	¾ tsp
		water as required	
Method of Preparation: Step 1: Take a grill safe deep bowl, add all the ingredients, mix well and place the bowl in on the mesh rack, select category IB57, enter recipe code and press start. Remove, set to cool and refrigerate. Serve chilled.			

Category	Recipe-	Ingredients:	
IB58	CHHENA PODA	Paneer	2 cup
		Suji	¾ cup
		Cardamom	½ tsp
		Raisins	few
		Roasted Cashews	Few
		Syrup:-	
		Ghee	1½ tbsp
		Sugar	1½ cup
Method of Preparation: "Take a mixing bowl, Add paneer , suji, cardamom, mix it and set aside for kneading, till it get a very mashed quality. Add sugar, nuts and mix it with paneer thoroughly to get a crumbly mixture finally. Step 1: Take a baking bowl, pour the ghee, sugar syrup in to a bowl, Pour in the paneer mix over the syrup and select category IB58, enter recipe code & press start to bake. Serve it warm."			

Category	Recipe-	Ingredients:	
IB59	NAAN KHATAI	Maida	150 g
		Suji	50 g
		Powdered sugar	85 g
		Vanilla essence	1 tsp
		Butter	100 g
		Almonds & cashewnuts	A few
Method of Preparation: "Cream the butter & sugar together till it turns fluffy. Add vanilla essence followed by maida & suji. Make a dough out of this mixture. Make medium sized balls & put cashew nut on the top of each piece. Step 1: Arrange them on crusty plate and place the plate in on the grill mesh rack, Select category IB59, enter recipe code & press start. "			

Category	Recipe-	Ingredients:	
IB60	SHAHI TUKDA	Roasted Bread Slices	3 slices
		Milkmaid	150 ml
		Milk	125 ml
		Sugar	3 tbsps
		Badam	Few
		Elaichi Powder	a pinch
		Pista Pieces	Few
		Kesar as per taste	
<p>Method of Preparation:"Take a mixing bowl, add milkmaid, milk, sugar, dry fruits and kesar elaichi powder, mix well.</p> <p>Step 1: Take a microwave oven safe flat glass dish, pour the mixture on the slices and select category IB60, enter recipe code & press start. Serve hot."</p>			

Category	Recipe-	Ingredients:	
IB61	BREAD PUDDING	Bread Crumbs	250 gms
		Sugar	200 gram
		Milk	¼ liter
		Butter	50 gms
		Chocolate	20 gram
		Eggs (Yolks & White Suppurate)	4
		Vanilla Essence	1 tsp
<p>Method of Preparation:"Soak bread crumbs in milk and press dry, add butter mixed sugar, chocolate, egg yolks, Mix well and add vanilla essence, egg white, mix all ingredients well and set a side.</p> <p>Step 1: Pour the pudding in lightly greased glass bowl and place it in the microwave, select category IB61, enter recipe code and press start."</p>			

Category	Recipe-	Ingredients:	
IB62	PURAN POLI KA PURAN	Chana Dal, Soaked & Cooked	1½ cup
		Jaggery Grated	1½ cup
		Turmeric Powder	¼ tsp
		Cardamom Powder	½ tsp
		Nutmeg Powder	½ tsp
		Oil If Required	
<p>Method of Preparation:Step 1: Take a microwave oven safe bowl; add all the ingredients, mix them well. Place the bowl in the microwave oven, select category IB62, enter recipe code and press start. Remove; add in flour flatten dough and make puran poli. Serve hot.</p>			

Category	Recipe-	Ingredients:	
IB63	PEDA	Soft Khoya	250 gms
		Sugar Powdered	1 cup
		Cardamom Powder	¼ tsp
		Cardamom Seeds (Crushed)	¼ tsp
		Pistachios	Few

Method of Preparation:

Step 1: Take a microwave oven safe glass bowl, add all ingredients other than cardamom seeds and pistachios, mix well and select category IB63, enter recipe code & press start. After the beep, remove and set to cool. When set well, make peda shape and garnish with cardamom seeds and pistachios on top and serve.

Category	Recipe-	Ingredients:	
IB64	RAVA LADOO	Rava	1 cup
		Coconut Grated And Roasted	¾ cup
		Sugar Powder	¾ cup
		Cardamoms	3
		Melted Ghee AsRequired	
		Raisins And Cashew Nuts As Needed	

Method of Preparation:

Step 1: Take a Microwave oven safe glass bowl, Add ghee, rava, mix well and select category IB64, enter recipe code & press start. (Stir twice in between) After the beep, remove and add powdered sugar, cardamoms, coconut, raisins. Add them to the blended mixture. Add ghee as needed and mix. Take small portions of the mix and roll to balls. Serve warm.

Category	Recipe-	Ingredients:	
IB65	BASUNDI	Milk	6 cups
		Sugar	2tbsp
		Chopped Almonds	6
		Lemon Juice	1½ tsp
		Crushed Cardamoms	6
		Chopped Charoli Nuts (Saara)	1 tsp

Method of Preparation:

Step 1: Take a microwave oven safe large bowl; add all ingredients other than almonds, cardamom and charoli, mix well. Place the bowl in the microwave oven, select category IB65, enter recipe code and press start. Remove, add all remaining ingredients and serve.

Category	Recipe-	Ingredients:	
IB66	RABDI	Milk	1 cup
		Grated paneer	1 cup
		Condensed milk	½ cup
		Deshi ghee	1 tbsp
		Elaichi powder	¼ tsp
		Saffron	A few strands
		Rose essence	A few drops
		Chopped pistachios	1 tbsp
		Chopped almonds (skin removed)	2 tbsp
<p>Method of Preparation:</p> <p>"Dissolve strands of saffron in 2 tbsp lukewarm milk.</p> <p>Step 1: In a microwave oven safe bowl, put all the ingredients of rabdi except chopped pistachios. Mix them well. Keep the bowl in Microwave. Select category IB66, enter recipe code & press start. Serve chilled garnished with chopped pistachios."</p>			

Category	Recipe-	Ingredients:	
IB67	FRUIT CUSTURD	Custard Powder	1 cup
		Milk	5 cup
		Sugar	1 cup
		Apple	2
		Banana	3
		Pineapple Slices	½ cup
		Strawberries	½ cup
		Black Grapes (Seedless)	½ cup
		Green Grapes (Seedless)	½ cup
		Cherries To Garnish	½ cup
<p>Method of Preparation:</p> <p>"Step 1: Take a microwave oven safe large glass bowl; add milk, sugar and mix well. Place the bowl in the microwave oven, select category IB67, enter recipe code and press start.</p> <p>Step 2: When the oven beeps, remove and add custard powder, mix well and press start. Slice the apple, banana, pineapple into pieces and put them into a bowl, which is large enough to hold all the contents. The grapes and the strawberries need not be cut and should be added along with it. Add custard to the fruits and mix gently. Set to cool and serve</p>			

Category	Recipe-	Ingredients:	
IB68	SUJI KA HALWA	Suji – Roasted	2 cup
		Milk	2 cup
		Sugar	2 cup
		Ghee	1½ cup
		Cardamom Powder	1½ tsp
		Cashews	8
		Almonds	8
		Raisins	Few
		Water As Required	
<p>Method of Preparation:</p> <p>"Step 1: Take a microwave oven safe glass bowl; add the suji. Select category IB68, enter recipe code & press start (Stir once in between).</p> <p>Step 2: When the oven beeps, remove and add all other ingredients mix well and press start. Serve hot."</p>			

Category	Recipe-	Ingredients:	
IB69	SANDESH	Paneer (grated)	250 g
		Milkmaid	75 g
		Rose water	1½ tbsp
		Elaichi seeds	1 tsp
		Chopped pista	Few
		Khoa (mashed)	150 gm

Method of Preparation:

"Step 1: In a microwave oven safe bowl add grated paneer, khoa, rose water & milkmaid. Mix well. Select category IB69, enter recipe code and press start.

Step 2: When the oven beeps, stir well & press start. Allow to cool. Hang in Muslin cloth for 20 minutes if it is too wet. Make balls out of the mixture & roll them in elaichi powder & chopped pista. Refrigerate till set."

Category	Recipe-	Ingredients:	
IB70	PAYASAM	Milk	6 cups
		Vermicelli (Seviya)	1½ cups
		Sugar	1½ cup
		Cardamom	6
		Cashew Nuts	½ tbsp
		Almonds	½ tbsp
		Ghee	1 tbsp

Method of Preparation:

"Step 1: Take a microwave oven safe bowl, add all the ingredients other than milk, sugar, cardamom, select category IB70, enter recipe code & press start.

Step 2: When the oven beeps, remove and add the remaining ingredients, mix well and press start. Serve hot."

Category	Recipe-	Ingredients:	
IB71	SABUDANA KHEER	Sabudana Soaked	1 cup
		Milk	2 cup
		Sugar	¾ cup
		Cardamom Powder	½ tsp
		Cashews For Garnish	¾ tbsp
		Raisins For Garnish	¾ tbsp
		Ghee	1½ tbsp
		saffron, soaked in 1 tbsp milk	

Method of Preparation:

"Step 1: Take a microwave oven safe bowl. Add sabudana and mix well. Select category IB71, enter recipe code & press start.

Step 2: After the beep, remove and add ghee, milk, sugar, cardamom powder, mix well and press start. Then add the saffron milk and garnish with nuts and raisins. Serve warm."

Category	Recipe-	Ingredients:	
IB72	SEVIYA KHEER	Seviya	3 cup
		Milk	6 cup
		Condensed Milk	1½ cup
		Sugar	1½ cup
		Raisins	1½ tbsp
		Cashew Nut Pieces (Roasted)	1½ tbsp
		Almonds (Roasted)	1tbsp
		Powdered Elaichi (Cardamom)	Few
		Water As Required	

Method of Preparation:

"Step 1: Take a microwave oven safe bowl; add seviya and select category IB72, enter recipe code & press start.

Step 2: When the oven beeps, remove and add all the ingredients except elaichi powder and raisins mix well and press start.

Step 3: When the oven beeps, remove and add all remaining ingredients. Mix well and press start. Serve hot."

Category	Recipe-	Ingredients:	
IB73	MYSORE PAK	Besan	2 cup
		Melted ghee	1 cup
		Powdered Sugar	1 cup
		Milk	½ cup

Method of Preparation:

Step 1: Take a microwave oven safe flat glass dish add besan. Select Category IB73 & press start.

Step 2: When the oven beeps, mix well & add melted ghee, powdered sugar. Mix very well while adding and press start.

Step 3: When the oven beeps, mix well & add milk. Press start. Allow to cool & cut into pieces & serve.

Category	Recipe-	Ingredients:	
IB74	KADDU KI KHEER	Grated Pumpkin	2 cup
		Milk	2 cup
		Ghee	2 tbsp
		Sugar	2 tbsp
		Cardamom Powder	¼ tsp
		Saffron Strands	5
		Almonds Thinly Sliced	4

Method of Preparation:

"Step 1: Take a microwave oven safe bowl, add all the ingredients other than cardamom, saffron and almonds and mix well. Select category IB74, enter recipe code & press start.

Step 2: When the oven beeps, remove and add the remaining ingredients, mix well and press start."

INTERNATIONAL RECIPES

Category	Recipe-	Ingredients:	
IN1	TOFU (THAI)	Tofu (Cut In To Cubes)	200 gr
		Chopped Onion	½ cup
		Sesame Oil	1½ tsp
		Olive Oil	1½ tsp
		Soya Sauce	2 tsp
		Grated Ginger	1 tsp
		Chunky Peanut Butter	¼ cup
		Flaked Coconut	
		Sesame Seeds	1½ tbsp
<p>Method of Preparation:</p> <p>"Step 1: In a MWO safe bowl add olive oil, sesame oil, onion, tofu, Soya sauce, peanuts butter, ginger, stir carefully without breaking the tofu, until well incorporated, and select category IN1, enter recipe code & press start.</p> <p>Step 2: when the oven beeps, remove the bowl from microwave oven, add flaked coconut, and sprinkle sesame seeds. Cover the bowl with lid and press start. Serve hot. "</p>			

Category	Recipe-	Ingredients:	
IN2	ITALIAN VEGGIE PIZZA	Pizza Base	1
		Butter	1 tbsp
		Chopped Cabbage	¼ cup
		Chopped Green Pepper	¼ cup
		Chopped Mushrooms	¼ cup
		Sweet Peas	¼ cup
		Chopped Carrot	¼ cup
		Tomato Ketch Up	2 tbsp,
		Red Chili Powder	1 tsp
		Grated Cheese	½ cup
		Salt To Taste	
<p>Method of Preparation:</p> <p>Step 1: Take a pizza base, apply butter, ketchup, some grated cheese on the pizza base and arrange all vegetables on it, pour the remaining grated cheese on the top of vegetables. Put pizza base on the grill mesh rack, place it in the oven and select category IN2, enter recipe code & press start. Cut in to pieces and Serve hot.</p>			

Category	Recipe-	Ingredients:	
IN3	MOYETTES (MEXICAN)	Mushrooms (Quartered)	1 cup
		Tomatoes (Chopped)	1 cup
		Crushed Garlic	1 clove
		Chopped Green Chillies	1 tsp
		Onions Chopped	1 cup
		Red Chilly Powder	½ tsp
		Roasted Cumin Seeds Powder	1 tsp
		Sugar	2 tsp
		Butter	3 tbsp
		Salt To Taste	
		Bread Buns	
		Grated Cheese	
		(Option For The Topping)	
		Shredded Cabbage	
		Grated Carrot	
		Chopped Spring Onions	

Method of Preparation:

"Take a mixing bowl, add 2 tbsp butter, onion, mushrooms, tomato, garlic, green chily, chilly powder. Cumin's seed powder, sugar, salt, mix all ingredients.

Step 1: Cut off the tops from the buns, scoop out the canter, and fill the canter with some mixed vegetable and top with some grated cheese; apply 1 tbsp butter lightly on to all buns. Arrange all buns in on a crusty plate and put it on grill rack and select category IN3, enter recipe code & press start. Take out moyettes from oven and top with cabbage, carrot, spring onions and serve."

Category	Recipe-	Ingredients:	
IN4	SPANISH FLAN	White Sugar	2 cup
		Eggs	6
		Sweetened Condensed Milk	1 cup
		Evaporated Milk (Thick)	1 cup
		Vanilla Extract	¼ tsp

Method of Preparation:

"Step 1: Take sugar in a microwave oven safe bowl, add little water and select category IN 4, enter recipe code & press start to melt the sugar.

Step 2: When you hear a beep, remove and press start to preheat the oven.

Step 3: After the beep, add beaten eggs, condensed milk, evaporated milk and vanilla extract, in to melted sugar and blend all ingredients until smooth. Pour the egg mixture in a Baking dish. Set the baking dish in a pre-heated oven and press start. Let cool completely to serve."

Category	Recipe-	Ingredients:	
IN5	SPANISH BAKED FISH	Fish	300 g
		Butter	2 tbsp
		Sour cream	½ cup
		Bread crumbs	1 cup
		Grated cheese	¼ cup
		Parsley (for garnish)	

Method of Preparation:

"Marinate fish with butter and sour cream for 15 minutes.

Step 1: Put the marinade fish in a microwave oven safe bowl and cover with lid then select category IN5, enter recipe code & press start.

Step 2: When the oven beeps, press start to preheat the oven.

Step 3: Sprinkle with breadcrumbs and grated cheese over fish and put in on high rack and press start. Garnish with parsley. Serve hot." oven and press start. Let cool completely to serve."

Category	Recipe-	Ingredients:	
IN6	SPANISH BAKED CHICKEN	Chicken	300 g
		Tomato Sauce	2 tbsp
		Butter	1 tbsp
		Bread-Crums	2 tbsp
		Boiled Rice For Serve	2 cup

Method of Preparation:

"Step1: Take a microwave oven safe bowl, add chicken with butter, salt & pepper and select category IN6, enter recipe code & press start.

Step 2: When the oven beeps, press start to preheat the oven.

Step 3: Put the chicken in a baking dish (top rack) pour over tomato sauce highly seasoned, sprinkle with bread-crumbs and press start."

Category	Recipe-	Ingredients:	
IN7	LASAGNA (ITALIAN)	Butter (Melted)	2 tbsp
		Flour	2 tbsp
		Milk	1 cup
		Garlic	½ tsp
		Chicken Broth	½ cup
		Cheese	1 cup
		Onions Chopped	2
		Salt To Taste	
		Basil (Dried)	½ tsp
		½ Tsp Oregano Leaves (Dried)	½ tsp
		½ Tsp Pepper	½ tsp
		Lasagne Layers (Cooked)	4
		Chicken Chunks	1 cup
		Spinach	50 gms
		*Béchamel Sauce; *	1½ Cup
		*Béchamel Sauce; *	1½ Cup
		Flour	10 gram
		Butter	10 gram
		Milk	100 gram
		Bay Leave	3
		Nutmeg	pinch of
		Salt	pinch of
		A Pinch Of Block Pepper	Few

Method of Preparation:

"Step 1: Take a microwave oven safe bowl, add butter, onions, spinach, flour, salt, milk, broth, cheese, basil, oregano, pepper, chicken chunks and stir. Select category IN7, enter recipe code & press start. When the oven beeps, remove and keep it aside to cool. Spread the béchamel sauce mixture in the bottom of the baking dish and spread the cheese. Arrange Lasagne layer over the sauce. Pour some chicken, spinach mixture, cheese, over the lasagne layer and spread remaining sauce evenly over lasagne layers and sprinkle with cheese.

Step 2: Press start to preheat oven.

Step 3: When the oven beeps, insert baking dish in preheated oven and press start to bake."

Category	Recipe-	Ingredients:	
IN8	QUICHE (FRENCH)	Eggs	2
		Light Cream	½ cup
		Nut Mug	Pinch of
		Pepper	½ tsp
		Spinach (Broccoli, Optional)	300 gr
		Bacon (Cooked & Crumbled)	2 slices
		Cheese	½ cup
		Chopped Onions	¼ cup
		Salt To Taste	

Method of Preparation:

"Step 1: Mix all ingredients together and pour it into lightly greased oven safe bowl, select category IN8, enter recipe code & press start.

Step 2: When the oven beeps, press start to preheat oven.

Step 3: After the beep, remove and put quiche on the grill rack and press start to bake."

Category	Recipe-	Ingredients:	
IN9	THAI CHIKEN BALLS	Ground Chicken	300 g
		Bread Crumbs	1 cup
		Green Onions (Sliced)	½ cup
		Ground Coriander Seeds	Few
		Chopped Fresh Cilantro	2 tbsp
		Sweet Chili Sauce	2 tbsp
		Fresh Lemon Juice	1 tsp
		Oil	2 tbsp

Method of Preparation:

"In a MWO safe bowl mix together the chicken and bread crumbs, onion, coriander, Cilantros, chili sauce, lemon juice. Mix well. Using damp hands, form the mixture into evenly shaped balls that are either small enough to eat as mini balls or large enough to use it as a filling for burgers. Apply oil lightly to all the balls from outside. Arrange the balls on the crusty plate.

Step 1: Select category IN9, enter recipe code & press start to pre-heat the oven.

Step 2: When the oven beeps, place the crusty plate in on grill rack and press start to bake the balls. Serve hot."

Category	Recipe-	Ingredients:	
IN10	THAI SPICED SHRIMP(PRAWNS)	Medium Shrimp (Peeled & Deveined)	300 g
		Fresh Lemon Juice	3 tbsp
		Soy Sauce	1 tbsp
		Mustard	1 tbsp
		Garlic, Minced	2 cloves
		Brown Sugar	1 tbsp
		Curry Paste	2 tsp

Method of Preparation:

"Take a microwave oven safe bowl, add and mix together the lemon juice, soy sauce, mustard, garlic, brown sugar, curry paste, shrimp and marinate it in the refrigerator for 1 hour. Transfer the marinate to a baking tray.

Step 1: Select category IN10, enter recipe code & press start to preheat the oven.

Step 2: When the oven beeps, place the baking try in on the grill rack and press start. Serve hot."

Category	Recipe-	Ingredients:	
IN11	ENGLISH MUFFINS. (ENGLAND)	Warm Milk	¾ liter
		Dissolved Yeast	½ cup
		Grounded Sugar	1 tsp
		Flour (Enough To Make Stiff Batter)	
		Butter	½ cup
		Soda (Dissolved In A Little Water)	1 tsp

Method of Preparation:

"Take a mixing bowl, add warm milk, yeast, sugar and enough flour to make a stiff batter. Let it stand for 1 hour to rise. Add melted butter and soda. Take enough flour to make a very stiff batter and let it rise for one hour. Fill the batter into well-greased muffin rings or plate.

Step 1: Select category IN11 & press start to preheat the oven.

Step 2: Put the muffin rings in pre-heated oven and press start to bake."

Step 2: When the oven beeps, place the baking try in on the grill rack and press start. Serve hot."

Category	Recipe-	Ingredients:	
IN12	CHOCOLATE-BREAD PUDDING(ENGLAND)	Bread Crumbs	300 gr
		Milk	½ liter
		Butter	50 gram
		Sugar	100 gram
		Chocolate	70 gram
		Eggs (Yolks& White Suppurate)	4
		Vanilla Essence	¼ tsp

Method of Preparation:

"Soak the bread crumbs in milk and dry them, add butter mixed sugar, chocolate, and egg yolks, vanilla essence and egg white. Mixes all the ingredients well and set it aside.

Step 1: Select category IN12, enter recipe code & press start to preheat the oven. Pour the pudding in lightly greased baking dish.

Step 2: place the baking dish on the grill rack and press start."

Category	Recipe-	Ingredients:	
IN13	APPLE SOUFFLE (FRENCH)	Apples, Peeled & Chopped	2 big size
		Eggs (Divide In To Yolks& White)	2
		Butter	2 tbsp
		Sugar	2 tbsp
		Lime Juice	1 tsp
		Lemon Rind	¼ tsp

Method of Preparation:

"In a bowl, add apples and butter. Mash well. Take another mixing bowl, beat the yolk of eggs with sugar, apple mash, lime juice, rind of lemon, mix well and add the egg white to it. Mix properly.

Step 1: Select category IN13, enter recipe code, & press start to preheat the oven.

Step 2: Pour the apple mixture in a buttered pudding dish and press start to bake."

Category	Recipe-	Ingredients:	
IN14	MEXICAN VEG - KEBABS	Green Peppers (Cut In To Large Slices)	1 cup
		Yellow Peppers (Cut In To Large Slices)	1 cup
		Baby Corns (Cut In To Two)	1 cup
		Cottage Cheese (Paneer) Large Slices	1 cup
		Mushrooms	1 cup
		White Onions (Cut In To Large Slices)	1 cup
		Chili Powder	2 tsp
		Cocoa Powder	2 tsp
		Crushed Garlic	4 cloves
		Oregano	½ tsp
		Fresh Curd	1 tbsp
		Sour Cream For Serve	1 cup
		Spring Onions (Chopped) For Garnish	½ cup
		Salt To Taste	
		Pepper To Taste	

Method of Preparation:

"Take a mixing bowl; add green and yellow peppers, baby corns, cottage cheese, mushrooms, white onions, chili powder, cocoa powder, garlic, oregano, curds, salt and pepper. Stir all ingredients and allow marinating for 4 hours. Arrange one piece each of all vegetables on the skewer.

Step 1: Select category IN14, enter recipe code & press start to pre heat the oven.

Step 2: When the oven beeps, insert skewer properly in oven and press start. Serve hot with sour cream and spring onions."

Category	Recipe-	Ingredients:	
IN15	APPLE CAKE (FRENCH)	Finely Chopped Apples	2 cups
		Sugar	1½ cup
		Egg (Beaten)	1
		Flour	1 cup
		Cinnamon	½ tsp
		Baking Powder	½ tsp
		Vanilla Extract	¼ tsp
		Raisins (Kismis)	2 tbsp
		Nuts (Chopped)	2 tbsp

Method of Preparation:

"Place apples in large mixing bowl, add sugar, stir and let stand for ½ hour. Add egg, flour, cinnamon, baking powder, nuts, and raisins and blend well.

Step 1: Select category IN15, enter recipe code & press start to preheat the oven.

Step 2: When the oven beeps, pour the mixture in to lightly greased baking dish and press start to bake. Serve with powdered sugar sprinkled over cake."

Category	Recipe-	Ingredients:	
IN16	CINNAMON HONEY WINGS(ITALIAN)	Chicken Wings	300 gr
		Garlic (Chopped)	4 cloves
		Olive Oil	2 tbsp
		Soy Sauce	2 tbsp
		Rice Vinegar	¼ cup
		Honey	¼ cup
		Cinnamon (Ground)	¼ tsp
		Thyme	1 tsp
		Ginger (Ground)	½ tsp
		Mustard (Dry)	½ tsp
<p>Method of Preparation:</p> <p>"Take a mixing bowl; add oil, garlic, ginger, mustard, thyme, cinnamon, honey, vinegar, soy sauce, chicken wings.</p> <p>Mix well and set it aside for 2 hours to marinade.</p> <p>Step 1: Select category IN16, enter recipe code & press start to pre heat the oven.</p> <p>Step 2: When the oven beeps, Arrange the chicken wings on lightly greased baking dish and press start. Serve hot. "</p>			

Category	Recipe-	Ingredients:	
IN17	CHINESE LO MEIN	Cooked Chinese Noodles (Spaghetti)	2 cups
		Diced Cooked Chicken	200gm
		French Beans (Thawed)	100gm
		Bean Sprout	1 cup
		Scallions (Chopped)	2
		Gingers (Shredded)	½ slice
		Garlic (Minced)	1 clove
		Lime Juice	1 tsp
		Sugar	1 tsp
		Soya Sauce	1 tbsp
		Oil	1½ tbsp
		Sesame Oil	½ tsp
		Sherry	1 tbsp
<p>Method of Preparation:</p> <p>"Step 1: Mix together soya sauce, lime juice, sugar and set it aside. Take a MWO safe bowl, add vegetable oil, garlic, ginger, scallions, bean sprouts, french beans, sherry, and mix well and select category IN 17, enter recipe code & press start. Set it aside.</p> <p>Step 2: Take another MWO safe bowl, add sesame oil, cooked noodles and cooked chicken, soya sauce mixture, stir and Press start.</p> <p>Step 3: After the beep, now add the vegetables, mix thoroughly and press start. Serve hot."</p>			

Category	Recipe-	Ingredients:	
IN18	CHINESE GARLIC CHICKEN	Boneless, Skinless, Chicken Breasts(Cut In To Thin Shreds)	400 gm
		Egg White	2
		Corn Starch	3 tbsp
		Sherry	1 tbsp
		Green Onion (Cut In To Thin Slices)	½ cup
		Ginger (Minced)	1 tsp
		Garlic (Minced)	3 tsp
		Oil As Required	
		Sauce:	
		Crushed Chilly Paste	1 tsp
		Corn Starch	1 tsp
		Sugar	1 tsp
		Rice Vinegar	2 tsp
		Sherry	2 tbsp
		Soya Sauce	2 tbsp
		Sesame Oil	1 tsp
		Water As Required	

Method of Preparation:

"Marinate chicken with egg white, sherry, and starch, mix well, and set it aside for 30 minutes.

Step 1: Take a MWO safe bowl, add oil, onions, ginger, garlic, chili paste, sugar, cornstarch, rice vinegar, combine all ingredients mix well and select category IN18, enter recipe code & press start.

Step 2: When the oven beeps, remove and add marinade chicken stir and press start.

Step 3: After the beep, remove and add water, sherry, soya sauce in to chicken mixture stir and press start. Splash with 1 tsp of dark sesame oil. Serve over rice.

"Step 2: Take another MWO safe bowl, add sesame oil, cooked noodles and cooked chicken, soya sauce mixture, stir and Press start.

Step 3: After the beep, now add the vegetables, mix thoroughly and press start. Serve hot."

Category	Recipe-	Ingredients:	
IN19	NEW YEAR'S NOODLES(CHINA)	Noodles	3 cups
		Mushrooms (Chopped)	1 cup
		Vegetable Broth	1 cup
		Soy Sauce	2 tbsp
		Corn Starch	3 tbsp
		Sugar	1 tsp
		Peanut Oil	2 tbsp
		Minced Garlic	1 tsp
		Minced Ginger	1 tsp
		Chopped Cabbage	1 cup
		Bean Sprouts	1 cup
		Chopped Spring Onion	½ cup
		Chopped Scallions (For Garnish)	2

Method of Preparation:

"Soak mushrooms in warm water for 15 minutes and cut it into bite sized pieces. While the mushrooms are soaking, make the sauce by mixing vegetable broth, soy sauce, cornstarch and sugar in a small bowl and set it aside. Step 1: Take the noodles and water into a microwave oven safe bowl and select category IN19, enter recipe code and press start. Allow it to cool.

Step 2: When the oven beeps, take another bowl; add oil, garlic, ginger, mushrooms, cabbage, bean sprouts, and spring onion, stir and press start.

Step 3: After the beep, remove and add sauce, noodles and press start Garnish with scallions and serve."

Category	Recipe-	Ingredients:	
IN20	PRAWN CURRY (THAI)	French Beans	400 gm
		Prawns	1 cup
		Mushrooms (Sliced)	1 cup
		Red Pepper (Cut In To Slices)	3 cloves
		Thai Red Curry Paste	2 cups
		Chicken Stock	1 tsp
		Thai Fish Sauce	½ inch
		Coconut Milk	¼ tsp
		Basil	½ cup
		Coriander	3
		Lime Juice	1 tsp
		Olive Oil	¼ cup
		Basmati Rice (Cooked)	
		Thai Red Curry Paste	
		5 Red Chillies (Soaked In Warm Water/ Drained)	
		Chopped Onions	¼ Cup
		Peeled Garlic	2 Cloves
		Grated Ginger	½ Tbsp
		Lemon Grass	1 Stalk
		Coriander	1 Stalk
		Coriander Seeds (Dania)	1 Tbsp
		White Pepper	½ Tbsp
		Salt	½ Tsp
<p>Method of Preparation:</p> <p>"Step 1: Take a MWO safe bowl, add oil, beans, red peppers, mushrooms and thai red curry paste. Mix well and select category IN20, enter recipe code & press start.</p> <p>Step 2: When the oven beeps, remove and add prawn, chicken stock, fish sauces, basil, coriander, coconut milk, lime juice, stir and press start. Serve over basmati rice."</p>			

Category	Recipe-	Ingredients:	
IN21	FRITTATA (ITALIAN)	Eggs	4
		Red Capsicums	½ cup
		Yellow Capsicum	½ cup
		Zucchini	½ cup
		Fresh Basil Leaves	Few
		Crushed Black Pepper	½ tsp
		Thai Fish Sauce	
		Oil As Required	
		Salt To Taste	
<p>Method of Preparation:</p> <p>"Beat the eggs in a bowl with salt & pepper. Set it aside.</p> <p>Step 1: Take a MWO safe bowl add oil, red capsicum, yellow capsicum, zucchini, basil, crushed black pepper, stir and select category IN21, enter recipe code & press start.</p> <p>Step 2: When the oven beeps, remove and pour the egg mixture in it, cover the bowl with lid, mix well and press start.</p> <p>Step 3: When the oven beeps, remove and turn over and press start. Serve hot. "</p>			

Category	Recipe-	Ingredients:	
IN22	SPANISH OMELETTE	Olive Oil	3 tbsp
		Onion (Minced)	2 cup
		Boiled Potato (Minced)	2 cup
		Salt	¼ tsp
		Eggs, Beaten	5
<p>Method of Preparation:</p> <p>"Step 1: Take a microwave oven safe bowl; add oil, onion, potato, salt, stir and select category IN 22, enter recipe code & press start.</p> <p>Step 2:When the oven beeps, remove and add beaten eggs on the top of potato mix and press start.</p> <p>Step 3:When the oven beeps, remove and turn potato and eggs mixture and press start. Serve hot."</p>			

Category	Recipe-	Ingredients:	
IN23	IRISH EGGS(ENGLAND)	Butter (Melted)	2½ tbsp
		Potatoes (Cut In To Slices)	1½ cup
		Onion (Minced)	1 cup
		Green Bell Pepper (Chopped)	1 cup
		Eggs (Beaten)	5
<p>Method of Preparation:</p> <p>"Step 1: Take a microwave oven safe bowl; add butter, potatoes, onion and green peppers. Stir and select category IN23, enter recipe code & press start.</p> <p>Step 2:When the oven beeps, remove and stir the eggs and press start. Serve warm."</p>			

Category	Recipe-	Ingredients:	
IN24	SCRAMBLED EGGS (ENGLAND)	Eggs	5
		Mozzarella Cheese	¼ cup
		Butter (Melted)	¼ cup
		Milk	3 tbsp
		Onion (Chopped)	2 cup
		Mushrooms (Chopped)	2 cup
<p>Method of Preparation:</p> <p>"Step 1: Take a microwave oven safe bowl; add butter, onion, mushrooms stir and select category IN24, enter recipe code & press start.</p> <p>Step 2: When the oven beeps, remove and break eggs in to a bowl. Whip until fully beaten. Add milk, mix well and press start. Place cheese slice on the top of the eggs, cover with lid and stand un til cheese melts. Serve hot."</p>			

Category	Recipe-	Ingredients:	
IN25	CHINESE FRIED RICE	Eggs	2
		Ground White Pepper	¼ tsp
		Soya Sauce	¼ cup
		Rice (Cooked)	4 cups
		Scallions Including Green Ends(Chopped)	½ cup
		Chicken (Diced)	2 cup
		Ginger (Minced)	1 slice
		Garlic (Minced)	1 clove
		Sliced Mushrooms (Optional)	½ cup
		Oil	¼ cup

Method of Preparation:

"Put first three ingredients in a mixing bowl and stir slightly; eggs should not be well beaten. Keep it side.

Step 1: Take a microwave oven safe bowl, add oil, garlic, ginger, scallions, chicken, and mushrooms, mix all Ingredients and select categoryIN25, enter recipe code & press start.

Step 2: When the oven beeps, remove and add the rest of the ingredients. Cooked rice and egg mixture; stir constantly until thoroughly mixed. Coat with oil and press start. Serve hot."

Category	Recipe-	Ingredients:	
IN26	GREEN CURRY CHICKEN	Boneless, Skinless, Chicken Breast(Cut Into 1 Inch Cubes)	300 g
		Dark Soya Sauce	½ tbsp
		All Purpose Flour	2 tbsp
		Oil	2 tbsp
		Green Curry Paste	3 tbsp
		Green Onions With Tops (Chopped)	2
		Cloves Garlic (Peeled & Chopped)	3
		Garlic (Minced)	3
		Ginger	1 tsp
		Coconut Milk	2 cup
		Fish Sauce	1 tbsp
		Soya Sauce	½ tbsp
		White Sugar	2 tbsp
		Cilantro Leaves For Garnish	½ cup
		Cilantro Leaves For Garnish	
		Green Chillies (Chopped)	12
		Garlic (Peeled)	6 Cloves
		Large Onion (Chopped)	1
		Ginger (Peeled)	1" Piece
		Coriander (Chopped)	1 Cup
		Lemon Juice	1 Tsp
		Ground Coriander	1 Tbsp
		Cumin (Ground)	2 Tsp
		Lemon Grass	2 Stalks
		Salt	1 Tsp
		Pepper	½ Tsp

Method of Preparation:

"Put first three ingredients in a mixing bowl and stir slightly; eggs should not be well beaten. Keep it side.

Step 1: Take a microwave oven safe bowl, add oil, garlic, ginger, scallions, chicken, and mushrooms, mix all Ingredients and select categoryIN26,enter recipe code & press start.

Step 2: When the oven beeps, remove and add the rest of the ingredients. Cooked rice and egg mixture; stir constantly until thoroughly mixed. Coat with oil and press start. Serve hot."

Category	Recipe-	Ingredients:	
IN27	PASTA CHICKEN (ITALIAN)	Chicken Breast (Diced)	300 g
		Broccolis (Diced)	½
		Garlic Cloves (Minced)	5
		Basil	¼ tbsp
		Oregano	¼ tbsp
		Carrots (Cut In To Small Pieces)	½ cup
		Ripe Tomatoes	½ cup
		Shell Pasta	1½ cup
		Olive Oil	1½ cup
		Tomato Juice Or Chicken Broth	½ cup

Method of Preparation:

"Step 1: Take a MWO safe bowl; add water, pasta, and broccoli, mix well and select category IN27, enter recipe code & press start. Keep it aside.

Step 2: When the oven beeps, take another MWO safe bowl, add oil, tomatoes, garlic, basil, oregano, and chicken mix all ingredients and press start.

Step 3: When the oven beeps, remove and drain the boiled pasta and broccoli add in to cooked chicken. Stir well and cover the bowl with lid and press start to cook. Garnish with grated cheese and serve."

Category	Recipe-	Ingredients:	
IN28	COUNTRY STYLE CHICKEN STEW (ENGLAND)	Chicken (Cut In To Pieces)	300 g
		Potatoes (Cut In To Pieces)	1 cup
		Carrot (Cut In To Pieces)	½ cup
		Onion, Cut In To Pieces	1 cup
		Tiny Pearl Onions (Peeled)	5
		French Beans (Cut In To Pieces)	½ cup
		Cauliflower Florets	½ cup
		Springs Of Parsley	3
		Sugar	Few
		Soy Sauce	2 inch
		Scallions (Chopped)	½ tsp
		Salt To Taste	3
		Garlic (Crushed)	2 tbsp
		Whole Wheat Flour	6 cloves
		Salt To Taste	2 tbsp
		Water As Required	

Method of Preparation:

"Step 1: Take oil in a oven safe bowl, add flour, chicken, garlic, stir and select category IN28, enter recipe code, & press start.

Step 2: When the oven beeps, remove and add potatoes, carrot, turnip, french beans, cauliflower, onions, bay leaf, parsley, celery, water, thyme, and pepper corns, salt. Stir all ingredients and press start. Serve hot."

Category	Recipe-	Ingredients:	
IN29	CHICKEN CASSEROLE(ITALIAN)	Chicken (Cut In To Pieces)	300 g
		Baby Onions)	1 cup
		Tomatoes	1 cup
		Tomato Paste	1 cup
		Marjoram	¼ tsp
		Oregano	¼ tsp
		Button Mushrooms	1 cup
		Block Olives	1 cup
		Garlic	1 clove
		Chopped Parsley	Few
		Salt And Pepper To Taste	
		Water As Required	
		Oil As Required	

Method of Preparation:

"Step 1: Take a microwave oven safe bowl; add oil, garlic, onions, marjoram, oregano, chicken, block olives, stir well and select category IN29, enter recipe code & press start.

Step 2: When the oven beeps, remove and add tomatoes, tomato paste, mushrooms, water, parsley, salt & pep-per. Stir and press star. Serve hot."

Category	Recipe-	Ingredients:	
IN30	SPAGHETTI (MEXICAN)	Skinless, Bone Less Chicken Breast(Cut In To Small Pieces)	200 g
		Spaghetti Noodles (Broken In To Half)	2 cup
		Chopped Tomato	1 cup
		Onion	1 cup
		Cumin	1 tsp
		Chili Powder	2 tsp
		Cheese	½ cup
		Oil As Required	
		Salt And Pepper To Taste	
		Water As Required	

Method of Preparation:

"Step 1: Take a microwave oven safe bowl; add oil, broken spaghetti, stir well and select category IN30, enter recipe code & Press start.

Step 2: When the oven beeps, remove and add tomato, onion, chicken breasts, with cumin's, chili powder, Salt and pepper, mix well, pour water stir and cover the bowl with lid and press start. Garnish with cheese. Serve hot."

BREAKFASTS/SNACKS

Category	Recipe-	Ingredients:	
BS01	DALIYA KICHDI	Dalia (Broken Wheat)	1½ cup
		Mix Vegetable Chopped	1½ cup
		Onion Chopped	1½ cup
		Green Chillies	3
		Garlic, Ginger Paste	1½ tsp
		Turmeric Powder	a pinch
		Cumins Seeds	1½ tsp
		Coriander Powder	1½ tsp
		Oil As Required	
		Salt To Taste	

Method of Preparation:

Step 1: Take a microwave oven safe bowl, add all ingredients other than dalia and coriander leaves. Mix well, select category BS01, enter recipe code and press start.

Step 2: When the oven beeps, remove, add the remaining ingredients other than the coriander leaf, mix well and press start. Remove, garnish with grated coriander and serve.

Category	Recipe-	Ingredients:	
BS02	NOODLES	Noodles	1½ cup
		Spring Onions	1½ tbsp
		Carrot Chopped	¼ cup
		Garlic Chopped	½ tsp
		Capsicum Chopped	1½ tbsp
		Pepper Powder	½ tsp
		Chili Sauce	1½ tsp
		Soya Sauce	1½ tsp
		White Vinegar	1½ tsp
		Beans Chopped (Optional)	¼ cup
		Finely Shredded Cabbage (Optional)	¼ cup
		Mushrooms Chopped (Optional)	¼ cup
		Salt To Taste	
		Oil As Required	

Method of Preparation:

"Step 1: Take a microwave oven safe bowl, add all the ingredients other than noodles. Mix well, Select category BS02, enter recipe code & press start.

Step 2: When the oven beeps, remove and add noodles. mix well and press start. Serve hot."

Category	Recipe-	Ingredients:	
BS03	VERMICELLI UPMA	Vermicelli, Roasted	2 cup
		Onion, Chopped	1½ cup
		Curry Leaves	Few
		Mustard Seeds	½ tsp
		Cumin	1 tsp
		Urad Dal	2 tbsp
		Green Chili, Chopped	1 tsp
		Red Chili	2
		Ginger	½ tsp
		Salt As Required	
		Oil As Required	

Method of Preparation:

"Step 1: Take a microwave oven safe bowl, add all ingredients other than roasted vermicelli, water, mix well and select category BS03, enter recipe code & press start.

Step 2: After the beep, remove and add all remaining ingredients, mix well and press start. Serve hot."

Category	Recipe-	Ingredients:	
BS04	BREAD UPMA	Bread slices (cut into small pieces)	2½ cup
		Oil	2½ tbsp
		Mustard seeds	1 tsp
		Jeera	1 tsp
		Curry leaves	Few
		Onion (chopped)	1 cup
		Chopped green chillies	4 nos.
		Chopped tomatoes	2 nos.
		Red chilli powder	1 tsp
		Lemon juice	1 tsp
		Turmeric powder	¼ tsp
		Salt to taste	

Method of Preparation:

"Step 1: In a microwave oven safe bowl add all ingredients other than bread slices, tomatoes, lemon juice, mix well, Select category BS04, enter recipe code and press start.

Step 2: When the oven beeps, remove and add other remaining ingredients, mix well and press start. "

Category	Recipe-	Ingredients:	
BS05	BREAD CHIVDA	Bread Slices	250 gms
		Mustard Seeds	½ tsp
		Cumin Seeds	1 tsp
		Onion Finely Chopped	1
		Turmeric Powder	¼ tsp
		Hing	a pinch
		Curry Leaves	Few
		Raw Peanuts	1 tbsp
		Oil As Required	
		Salt To Taste	
		Coriander Leaves For Garnish	

Method of Preparation:

"Step 1: Take a microwave oven safe bowl; add all the ingredients other than bread slices, hing and coriander leaves, mix well and select category BS05, enter recipe code and press start.

Step 2: When the oven beeps, remove and add all remaining ingredients other than the coriander leave and mix well and press start. Remove, garnish with grated coriander and serve."

Category	Recipe-	Ingredients:	
BS06	ROTI KA CHIVDA	Leftover Chapattis, Cut In To Small Pieces	4
		Mustard Seeds	½ tsp
		Cumin Seeds	1 tsp
		Onion Finely Chopped	1
		Oil	¼ tsp
		Hing	a pinch
		Curry Leaves	Few
		Raw Peanuts	2 tbsp
		Oil As Required	
		Salt To Taste	
		Coriander Leaves For Garnish	

Method of Preparation:

Step 1: Take a microwave oven safe bowl; add all the ingredients other than chapatti, hing and coriander leaves.

After the beep, remove, add the remaining ingredients other than the coriander leave, mix well and select category BS06, enter recipe code & press start. Remove, garnish with grated coriander and serve.

Category	Recipe-	Ingredients:	
BS07	GUAJRATI BHAJI-HANDVO	Toovar Dal, Soaked	½ cup
		Urad Dal, Soaked	¼ cup
		Moong Dal, Soaked	¼ cup
		Chana Dal, Soaked	¼ cup
		Rice, Soaked	½ cup
		Curd	½ cup
		Palak Chopped	½ cup
		Methi Chopped	½ cup
		Suva Chopped	½ cup
		Oil	2 tbsp
		Lemon Juice	1 tsp
		Soda	pinch of
		Sugar	1 tsp
		Chilli Powder	1 tsp
		Turmeric Powder (Haldi)	¼ tsp
		Ginger-Green Chilli Paste	2 tsp
		Salt To Taste	
		Mustard Seeds	½ tsp
		Sesame Seeds	1 tsp
		Ajwain	½ tsp
		Hing	pinch of
<p>Method of Preparation:</p> <p>"Blend the dals, rice in a mixer to a smooth mixture. Transfer the mixture to a bowl, add the curds and mix well. Cover and keep aside to ferment overnight. Add all other ingredients, mix well and set aside for 20 minutes. Pour the mixture in a lightly greased baking dish. Step 1: Place the baking dish in on the turntable, select category BS07, enter recipe code and press start. "</p>			

Category	Recipe-	Ingredients:	
BS08	PAV BHAJI	Potato, chopped	1 cup
		Cauliflower, chopped	½ cup
		Capsicum, chopped	½ cup
		Green Peas, chopped	½ cup
		Chopped onion	1 cup
		Chopped tomato	½ cup
		Garlic paste	1 tsp
		Red chilli powder	1 tsp
		Pav bhaji masala	2 tsp
		Lemon juice	1 tsp
		Hara dhania	½ cup
		Butter	2 tbsp
		Water as required	
		Salt to taste	
		Salt To Taste	
		Pav for serve	
<p>Method of Preparation:</p> <p>Step 1: Take a microwave oven safe bowl, add all ingredients other than pav, water, mix well and select category BS08, enter recipe code & press start.</p> <p>Step 2: Remove After the beep, add all remaining ingredients, mix well press start. Step 3: After the beep, remove, mix well and press start.. Serve hot.</p>			

Category	Recipe-	Ingredients:	
BS09	IDLI	Idli Batter	250 gr
<p>Method of Preparation:</p> <p>Pour idli batter in lightly greased microwave safe idli stand. Pour some water in the bottom of the idli bowl and cover the bowl with lid. Place the bowl in the microwave oven, select category BS09, enter recipe code & press start. Remove After the beep & serve hot with sambar and coconut chutney.</p>			

Category	Recipe-	Ingredients:	
BS10	KHAMAN DOKHLA	Besan (Gram Flour)	2 cup
		Suji	2 tbsp
		Corn Flour	2 tsp
		Sugar	1½ tsp
		Turmeric Powder	½ tsp
		Citric Acid	1 tsp
		Soda-Bi-Carb	½ tsp
		Lemon Juice	2 tsp
		Mustard Seeds	¾ tbsp
		Green Chillies - Finely Chopped	2 tsp
		Amchoor Powder	½ tsp
		Salt To Taste	
		Oil As Required	
		Grated Coconut For Garnish	
		Coriander Leaves For Garnish	
		Water As Required	
<p>Method of Preparation:</p> <p>"Take gram flour, suji, curd, water, salt, mix well into a batter. Cover it and set aside for 4 hours to marinate. Add green chillies, ginger paste, turmeric, limejuice, oil, soda-bi-carb and mix into a smooth batter.</p> <p>Step 1: Pour into microwave oven safe lightly greased bowl, place in the microwave oven, select category BS10, enter recipe code and press start. For tempering use curry leaves, mustard seeds, oil, and green chillies. Garnish with coriander leaves and grated coconut. Serve with chutney."</p>			

Category	Recipe-	Ingredients:	
BS11	SWEET CORN SOUP	Corn Kernels	1½ cup
		Potato Finely Chopped	¼ cup
		Green Peas	¼ cup
		Chopped Carrots	¼ cup
		Chopped Beans	¼ cup
		Spring Onions Chopped	¼ cup
		Corn Starch	2 tbsp
		Butter As Required	
		Water As Required	
		Salt / Sugar To Taste	

Method of Preparation:

"Step 1: Take a microwave oven safe bowl. Add all the ingredients other than water and cornstarch, mix well select category BS11, enter recipe code and press start.

Step 2: After the beep, remove and add cornstarch and water, mixwell and press start. Serve warm with pepper."

Category	Recipe-	Ingredients:	
BS12	PUMPKIN SOUP	Pumpkin	250 gms
		Chopped Onion	1 cup
		Green Chillies	2
		Garlic, Finely Chopped	3
		Curry Powder	1 tsp
		Chili Powder	1½ tsp
		Black Pepper	Few
		Sugar	1½tsp
		Curry Leaves	Few
		Chicken Broth	1 cup
		Evaporated Milk	1 cup
		Coconut Milk	1 cup
		Butter As Required	
		Salt To Taste	

Method of Preparation:

"Step 1: Take a microwave oven safe bowl, add all the ingredients other than pumpkin, chicken broth, evaporated milk and coconut milk and mix well. Select category BS12, enter recipe code, press start.

Step 2: When the oven beeps, remove and add the remaining ingredients, mix well and press start."

Category	Recipe-	Ingredients:	
BS13	ASPARAGUS SOUP	Asparagus (Chopped)	1 cup
		Carrots Chopped	1 cup
		Celery Chopped	1½ tbsp
		Garlic Paste	1 tsp
		Corn Starch	2¼ cup
		Sugar	1½ tsp
		Bay Leaves	3
		Oil As Required	
		Water As Required	

Method of Preparation:

"Step 1: Take a microwave oven safe bowl. Add all ingredients other than water, corn starch, sugar, mix them well and select category BS13, enter recipe code and press start.

Step 2: After the beep, remove and add all remaining ingredients, mix them well and press start. Blend and strain the soup. Serve hot."

Category	Recipe-	Ingredients:	
BS14	MUSHROOM SOUP	Button Mushrooms	250 gms
		Chicken Stock	1½ cup
		Sprig Onions, Chopped Finely	½ tbsp
		Ginger Paste	½ tsp
		Block Peppers	Few
		Salt To Taste	

Method of Preparation:

"Step 1: In a microwave oven safe glass bowl, add all the ingredients other than mushrooms and salt, mix them well and select category BS14, enter recipe code & press start.

Step 2: After the beep, remove, add all remaining ingredients, mix well, and press start. Remove and serve."

Category	Recipe-	Ingredients:	
BS15	SWEET POTATO SOUP	Sweet Potato Chopped	250 gms
		Onion Chopped	1
		Nutmeg Powder	a pinch
		Black Pepper Powder	a pinch
		Milk Or Heavy Cream	1 cup
		Corn Flour	1 tbsp
		Vegetable Stock	1 cup
		Lemon Juice	1 tsp
		Butter	1 tbsp
		Salt To Taste	

Method of Preparation:

"Step 1: In a microwave oven safe bowl, add all the ingredients other than nutmeg powder, pepper powder, milk, vegetable stock and lemon juice. Mix them well and select category BS15, enter recipe code & press start.

Step 2: After the beep, remove and add all remaining ingredients, mix well and press start. Remove and make puree of the sweet potato mixture. Serve hot."

Category	Recipe-	Ingredients:	
BS16	HOT & SOUR SOUP	Water	1½ cup
		Chilli sauce	2 tsp
		Soya sauce	2 tsp
		Vinegar	As per taste
		Chopped capsicum,	½ cup
		Spring onions	½ cup
		Carrots	½ cup
		Cabbage	½ cup
		Paneer	½ cup
		Tomato sauce	2 tbsps
		Corn flour	2 tbsps
		Pepper	1 tsp
		Sugar	1 tsp
		Ajinomoto	a pinch
		Salt to taste	

Method of Preparation:

Step 1: In a microwave oven safe glass bowl add water, chili sauce, soya sauce, vinegar, sugar, salt, pepper powder and ajinomoto. Select category BS16, enter recipe code & press start.

Step 2: When the oven beeps, stir well & add all the chopped vegetables, stir well & add corn flour, tomato sauce, paneer pieces & press start.

Category	Recipe-	Ingredients:	
BS17	BABY POTATO SOUP	Baby Potato	250 gms
		Onion Chopped	1
		Nutmeg Powder	a pinch
		Black Pepper Powder	a pinch
		Milk Or Heavy Cream	1 cup
		Corn Flour	1 tbsps
		Vegetable Stock	1 cup
		Lemon Juice	1 tsp
		Butter	1 tbsps
		Salt To Taste	

Method of Preparation:

"Step 1: In a microwave oven safe bowl, add all the ingredients other than nutmeg powder, pepper powder, milk, vegetable stock and lemon juice. Mix them well and select category BS17, enter recipe code & press start.

Step 2: After the beep, remove and add all remaining ingredients, mix them well and press start. Remove and make puree of the baby potato mixture. Serve hot."

Category	Recipe-	Ingredients:	
BS18	CHICKEN CORN SOUP	Chicken Stock	6 cup
		Chicken Breast (Boneless)	2 cup
		Corn Kernels	1 cup
		Corn flour	2 tbsp
		Soy Sauce	1 tbsp
		Eggs (Beaten)	2
		Spring Onions	¾ cup
<p>Method of Preparation:</p> <p>"Step 1: In a microwave oven safe bowl, add all the ingredients other than chicken stock, eggs, mix them well and select category BS18, enter recipe code & press start.</p> <p>Step 2: After the beep, remove and add all remaining ingredients, mix well and press start. When beeps, Remove and blend it and strain the soup. Serve hot."</p>			

Category	Recipe-	Ingredients:	
BS19	CHICKEN SOUP	Chicken	250 gms
		Spring Onion Chopped	½ cup
		Eggs	1
		Black Pepper Powder	1 tsp
		Coconut Milk	½ cup
		Chicken Stock	½ cup
		Sugar	1 tsp
		Salt As Per Taste	
<p>Method of Preparation:</p> <p>"Step 1: Take a microwave oven safe bowl, add all the ingredients other than coconut milk and chicken stock, mix them well and select category BS19, enter recipe code & press start.</p> <p>Step 2: After the beep, remove, add the all-remaining ingredients, mix well, and press start. Remove and serve hot."</p>			

Category	Recipe-	Ingredients:	
BS20	VEGETABLE SOUP	Carrot – Chopped	½ cup
		Sweet Potato – Chopped	½ cup
		Onion – Chopped	½ cup
		Tomato Chopped	½ cup
		Vegetable Broth	2 cup
		Coconut Milk	1 cup
		Ginger Sliced	1 inch
		Garlic Chopped	2 clove
		Curry Powder	1 tsp
		Pepper Powder	1 tsp
		Salt To Taste	
<p>Method of Preparation:</p> <p>"Step 1: take a microwave oven safe bowl, add all the ingredients other than coconut milk & vegetable broth and mix well. Select category BS20, enter recipe code & press start.</p> <p>Step 2: When the oven beeps, remove and add coconut milk and vegetable broth mix well and press start. After the beep, Remove, allow to cool and blend in the vegetables in a juicer. Drain, reheat and serve."</p>			

Category	Recipe-	Ingredients:	
BS21	BROCCOLI SOUP	Butter	3 tbsp
		Broccoli	250 gr
		Onion, Chopped	1 cup
		Carrot, Chopped	½ cup
		All-Purpose Flour	3 tbsp
		Chicken Broth	4 cup
		Cream	½ cup
		Salt And Black Pepper To Taste	

Method of Preparation:

"Step 1: Put chicken pieces, cabbage, carrot, capsicum, mushrooms, spring onion bulbs, peppercorns and chicken stock in a microwave oven safe glass bowl. Select category BS21, enter recipe & press start.

Step 2: When the oven beeps, take the bowl out & add red chilli paste, vinegar, salt & sugar, cornflour dissolved in ¼ cup cold water & paneer pieces. Stir well & press start. Garnish with greens of spring onions.

Adjust seasonings & serve hot

Category	Recipe-	Ingredients:	
BS22	CARROT SOUP	Carrot – Chopped	1½ cup
		Sweet Potato – Chopped	1 cup
		Onion – Chopped	1 cup
		Vegetable Broth	1 cup
		Coconut Milk	1 cup
		Ginger Sliced	½ tsp
		Garlic Chopped	½ tsp
		Curry Powder	½ tsp
		Pepper Powder	½ tsp
		Salt To Taste	1 tsp

Method of Preparation:

Step 1: Take a microwave oven safe bowl, add all the ingredients other than coconut milk & vegetable broth and mix well. Select category BS22, enter recipe code & press start.

Step 2: After the oven beeps, remove, add coconut milk and vegetable broth mix well and press start. Remove, allow to cool and blend in the juicer. Drain, reheat and serve.

Category	Recipe-	Ingredients:	
BS23	SPINACH SOUP	Spinach (Palak), Chopped	2 cup
		Onions, Chopped	2 cup
		Garlic, Chopped	3
		Gram Flour (Besan)	2 tbsp
		Cumin Powder	1 tsp
		Bay Leaf	2
		Water	2 cup
		Oil	½ tsp
		Salt As Required	
		Pepper As Required	

Method of Preparation:

Step 1: Take a microwave oven safe bowl, add all ingredients other than spinach and mix well. Select category BS23, enter recipe code and press start. Step 2: When the oven beeps, remove and add spinach, mix well and press start.

After the oven beeps, when it cools; blend the spinach in a mixer. Strain and serve hot.

Category	Recipe-	Ingredients:	
BS24	BADAM SOUP	Almonds	1½ cup
		White Stock	3 cups
		Butter Melted	2 tsp
		Plain Flour (Maida)	2 tbsp
		Almond Essence	4 drops
		Fresh Cream	3 tbsp
		Almond Slivers For Garnish	3 tbsp
		Salt & Pepper To Taste	

Method of Preparation:

"Soak the almonds in hot water for 20 minutes, drain and remove the skin. Blend the almonds in a mixer till coarse. Keep aside.

Step 1: Take a microwave oven safe bowl, add butter, plain flour, almond coarse paste, white stock, mix well and select category BS24, enter recipe code & press start. After the beep, remove Add the fresh cream, salt and pepper and mix well. Serve hot garnished with almond slivers."

Category	Recipe-	Ingredients:	
BS25	LENTIL SOUP	Split Lentils	2½ cup
		Garlic, Ginger Paste	2 tsp
		Red Chilli Powder	2 tsp
		Turmeric Powder	½ tsp
		Green Chili, Chopped	3
		Salt To Taste	
		Coriander Leaves For Garnish	
		Water As Required	

Method of Preparation:

"Step 1: Take a microwave oven safe bowl, add all the ingredients other than water and coriander leaves, mix well. Select category BS25, enter recipe code & press start.

Step 2: When the oven beeps, remove and add the remaining ingredients other than coriander leaves and mix well and press start. Remove and garnish with coriander leaves. Serve hot."

Category	Recipe-	Ingredients:	
BS26	KALA CHANA SOUP	Black chana	1 cup
		Cumin seeds	1 tsp
		Hing	¼ tsp
		Pepper powder	½ tsp
		Ghee	2 tbsp
		Lemon juice	1 tsp
		Salt to taste	
		Water As Required	
		Spring onion (for garnishing)	

Method of Preparation:

"Step 1: Take a microwave oven safe bowl, add all the ingredients other than hing, lemon juice, water, spring onions, mix well and select category BS26, enter recipe code & press start.

Step 2: After the beep, remove add all remaining ingredients, mix well and press start. Remove, allow to cool and blend in the juicer. Drain, reheat and serve."

Category	Recipe-	Ingredients:	
BS27	SICHUAN SOUP	Boneless chicken pieces	½ cup
		Carrot (grated)	½ cup
		Capsicum (chopped)	½ cup
		Cabbage (shredded)	½ cup
		Mushrooms (sliced)	½ cup
		Paneer (pieces)	½ cup
		Spring onions (bulb & greens)	½ cup
		Peppercorns (freshly crushed)	Few
		Chicken stock	3 cup
		Corn flour	3 tbsp
		Vinegar	2 tsp
		Red chilli paste	1 tbsp
		Salt & sugar to taste	

Method of Preparation:

Step 1: Take a microwave oven safe bowl, add all ingredients other than spinach and mix well. Select category BS27, enter recipe code and press start.

Step 2: When the oven beeps, Remove and add spinach, mix well and press start.

After the oven beeps, when cool; blend the spinach in a mixer. Strain and serve hot.

Category	Recipe-	Ingredients:	
BS28	CHANNA CHAT	Green Chana / Kabuli Chana	¾ cup
		Potato Chopped	¾ cup
		Potato Chopped	¾ cup
		Onion Chopped	¾ cup
		Grated Raw Mango(Optional)	Few
		Green Chili Finely Chopped	Few
		Garam Masala	1 tsp
		Hing	A pinch
		Cumin Powder	1 tsp
		Chili Powder	1 tsp
		Lime Juice	1 tsp
		Coriander Leaves For Garnish	
		Salt To Taste	

Method of Preparation:

Step 1: Take a microwave oven safe bowl; add all the ingredients other than raw mango, hing and coriander leave. Place the bowl in the microwave oven. Select category BS28, enter recipe code and press start.

Step 2: After the beep, remove and add all remaining ingredients, mix well and press start. Garnish with coriander leaves and serve.

Category	Recipe-	Ingredients:	
BS29	MASALA PEANUTS	Peanuts	250 gms
		Red Chilli Powder	1 tbsp
		Gram Flour (Besan)	1½ cup
		Rice Flour	1 tbsp
		Coriander Powder (Dhania)	1½ tsp
		Turmeric Powder	1 tsp
		Salt To Taste	2 tsp
		Water As Required	

Method of Preparation:

"Mix all ingredients in a mixing bowl and set aside for 20 minutes to marinate.

Step 1: In a microwave oven safe glass bowl, add all marinated ingredients, Select category BS29, enter recipe code & press start.

Step 2: When the oven beeps, remove, stir well and press start. "

Category	Recipe-	Ingredients:	
BS30	KHANDVI	Besan	2 cup
		Butter Milk	4 cup
		Turmeric Powder	½ tsp
		Oil	¾ tbsp
		Sesame Seeds	2 tsp
		Mustard Seeds	¾ tsp
		Coconut Scraped	¾ tbsp
		Chopped Coriander	¾ tbsp
		Hing	a pinch
		Chopped Green Chillies	3
		Salt To Taste	

Method of Preparation:

"Step 1: Take butter milk in a microwave oven safe bowl, add besan, turmeric powder, oil, salt, sesame seeds, mustard, hing, coconut, coriander, green chillies & mix well to avoid lump formation. Place the bowl on the turntable in the microwave oven, select category BS30, enter recipe code & press start.

Step 2: When the oven beeps, remove, stir well and press start. When done, pour a cup full in a large flat plate. Spread as thin as possible with the back of a large flat spoon using circular outward movements. Allow to cool & cut into 1½ inch wide strips. Carefully roll each strip & Serve with chutney."

Category	Recipe-	Ingredients:	
BS31	MURMURA CHIWDA	Poha (Thin Flattened Rice)	1 cup
		Murmura (Puffed Rice)	2 cup
		Peanuts	1 cup
		Almonds	Few
		Cashew Nuts	Few
		Black Raisins	Few
		Coconut Flakes	Few
		Chopped Green Chillies	3
		Curry Leaves	Few
		Mustard Seeds	½ tsp
		Turmeric Powder	¼ tsp
		Sugar	1 tsp
		Oil As Required	
		Salt To Taste	

Method of Preparation:

"Step 1: Take a microwave oven safe bowl; add all the ingredients other than the poha, murmura and sugar. Mix well and select category BS31, enter recipe code and press start.

Step 2: When the oven beeps, remove and add the remaining ingredients, mix well and press start. Remove, and serve."

Category	Recipe-	Ingredients:	
BS32	CHIVDA	Thin White Poha	2 cup
		Raw Peanuts	¾ cup
		Chana Dal	2 tbsp
		Cashew Nuts	½ cup
		Coconut Slices	½ cup
		Raisins	1 tbsp
		Curry Leaves	Few
		Green Chili	2 tsp
		Turmeric Powder	¼ tsp
		Hing	a pinch
		Sugar	1 tsp
		Oil As Required	
		Salt To Taste	

Method of Preparation:

"Step 1: Take a microwave oven safe bowl, add all ingredients other than poha, cashew nuts, raisins, mix well and select category BS32, enter recipe code & press start.

Step 2: After the beep, remove and add all remaining ingredients, mix well and press start. serve hot."

Category	Recipe-	Ingredients:	
BS33	UGGANI	Puffed rice (murmura)	3 cup
		Besan (roasted)	2 tbsp
		Oil	1½ tbsp
		Mustard seeds (spluttered)	1 tsp
		Green chilli (chopped)	2 nos.
		Curry leaves	Few
		Coriander leaves (chopped)	2 tbsp
		Onion (chopped)	2 nos.
		Tomato (chopped)	2 nos.
		Lemon juice (optional)	1 tbsp
		Red chilli powder	1 tsp
		Garam masala	1 tsp
		Turmeric powder	¼ tsp
		Salt to taste	

Method of Preparation:

"Step 1: Take a microwave oven safe bowl, add all ingredients other than poha, cashew nuts, raisins, mix well and select category BS33, enter recipe code & press start.

Step 2: After the beep, remove and add all remaining ingredients, mix well and press start. serve hot."

Category	Recipe-	Ingredients:	
BS34	KOTHIMBIR VADI	Kothimbir (Hara Dhaniya)	300 g
		Besan	1½ cup
		Suji	4 tbsp
		Red chilli powder	1 tsp
		Baking powder	½ tsp
		Turmeric powder	1 tsp
		Salt to taste	

Method of Preparation:

"Mix all the ingredients together & make vadis out of it.

Step 1: Take a microwave oven safe idli maker bowl, add 1 cup water, Select category BS34, enter recipe code & press start.

Step 2: When you hear a beep, remove and place the vadis in idli plates. Keep in the bowl & cover and press start. Allow to stand for 3 minutes."

Category	Recipe-	Ingredients:	
BS35	SHAKARKANDI	Shakarkandi	250 gr
		Chat Masala	1 tsp p
		Salt to taste	
<p>Method of Preparation:</p> <p>"Step 1: In a microwave oven safe bowl, add ½ water. Keep the peeled off Shakarkandi in the bowl. Select category BS35, enter recipe code & press start.</p> <p>Step 2: After the beep, remove and it turn upside down and press start. Remove and sprinkle salt & chaat masala & serve hot."</p>			

Category	Recipe-	Ingredients:	
BS36	CORN CHAT	Sweat Corn Kernels	¾ cup
		Tomato Chopped To Small Pieces	¾ cup
		Cooked Potato Cut To Small Pieces	¾ cup
		Cucumber Cut To Small Pieces	¾ cup
		Chopped Coriander	½ tbsp
		Lime Juice	¼ tsp
		Chat Masala	2 tsp
		Cumins Powder	1 tsp
		Red Chili Powder	1 tsp
		Salt To Taste	
<p>Method of Preparation:</p> <p>"Step 1: In a microwave oven safe bowl, add all ingredients other than cucumber, coriander, lemon juice. Mix well and select category BS36, enter recipe code and press start.</p> <p>Step 2: After the beep, remove and add all remaining ingredients, mix well and press start."</p>			

Category	Recipe-	Ingredients:	
BS37	MUMPALLI ROAST	Mumpalli	250 gr
<p>Method of Preparation:</p> <p>"Step 1: In a microwave oven safe glass bowl, add mumpalli and select category BS37, enter recipe code and press start.</p> <p>Step 2: When the oven beeps, remove and mix well and press start. Serve hot."</p>			

Category	Recipe-	Ingredients:	
BS38	SWEET CORN	Whole Sweet Corns	2
<p>Method of Preparation:</p> <p>"Step 1: Remove the husk until three layers remain. Arrange the sweet corn of the turn table, Select category BS38, enter recipe code & press start.</p> <p>Step 2: When the oven beeps, remove and turn the corns up side down and press start. Set to cool. Deseed and serve."</p>			

Category	Recipe-	Ingredients:	
BS39	CHEESE SANDWICH	Bread slices	6
		Chopped onion	1 cup
		Chopped tomato	1 cup
		Chopped capsicum	1 cup
		Grated cheese	4 tbsp
		Pepper	½ tsp
		Butter	4 tbsp
		Sauce / spread	4 tbsp
		Salt To Taste	

Method of Preparation:

"On a bread slice apply butter, layer with sauce, spread chopped vegetables, sprinkle grated cheese. Cover it with the other bread slice.

Step 1: Keep the sandwich on high rack. Select category BS39, enter recipe code and press start.

Step 2: When the oven beeps, change the side of the sandwich & again press start."

Category	Recipe-	Ingredients:	
BS40	BUTTER TOAST	Bread slices	6
		Butter as required	
		Grated cheese	1 cup

Method of Preparation:

Apply butter on one side of all bread slices. Put the grated cheese on one slice & cover with other slice. Prepare all the toasts in same way.

Step 1: Keep the toasts on the high rack. Select category BS40, enter recipe code and press start.

Step 2: When the oven beeps, turn over the side & press start."

Category	Recipe-	Ingredients:	
BS41	SWEET POTATO TIKKI	Boiled Sweet Potato	300 grs
		Green Peas Cooked	1½ cup
		Black Pepper Powder	¾ tsp
		Ginger Paste	1½ tsp
		Garam Masala	1½ tsp
		Red Chili Powder	1½ tsp
		Cumins Powder	1½ tsp
		Oil as required	
		Salt to taste	

Method of Preparation: Mash sweet potatoes and green peas together. Add all the remaining ingredients, mix well and shape them as medium sized tikkis. Arrange tikki in a lightly greased crusty plate and place the crusty plate on the mesh rack in the microwave oven. Select category BS41, enter recipe code and press start. Turn once in-between. Serve hot.

Category	Recipe-	Ingredients:	
BS42	PAPADI CHAT	Crisp Papdis	1 cup
		Potato Boiled,	½ cup
		Boiled Chickpeas	½ cup
		Onion, Chopped	1 cup
		Tomato, Chopped	1 cup
		Chopped Coriander Leaves	¼ cup
		Red Chili Powder	1 tsp
		Cumin Powder	1 tsp
		Chaat Masala	1 tsp
		Lemon Juice	1 tsp
		Sev	3 tbsp
		Salt To Taste	

Method of Preparation:

Step 1: Take a Microwave oven safe bowl, combine all the ingredients, mix them well, keep bowl on the turn table and select category BS42, enter recipe code & press start. Remove and serve.

Category	Recipe-	Ingredients:	
BS43	POP CORN	Pop Corn	250 gms
		Butter	2 tsp
		Red Chilli Powder (Optional)	½ tsp
		Turmeric Powder	½ tsp
		Salt To Taste	

Method of Preparation:

"Step 1: Take a microwave oven safe large glass bowl, add all ingredients, mix well and place the bowl in the microwave oven, select category BS43, enter recipe code & press start. Remove and serve hot."

Category	Recipe-	Ingredients:	
BS44	APPLE MUFFINS	Maida	1 cup
		Apple Chopped	½ cup
		Caster Sugar	½ tsp
		Dark Choc Bits	¼ cup
		Oil	2 tbsp
		Cup Milk	¼ cup
		Vanilla Extract	¼ tsp
		Eggs	1

Method of Preparation:

"Step 1: Take a mixing bowl, add all ingredients to make a smooth batter, mix well and pour the batter in muffin tins and place the muffin tins in the microwave oven, select category BS44, enter recipe code & press start. Remove and serve hot."

Category	Recipe-	Ingredients:	
BS45	CHOCOLATE COCONUT BALLS	Milkmaid	1 cup
		Marie biscuit powder	1 cup
		Milk powder	½ cup
		Bournvita	½ cup
		Grated coconut	½ cup

Method of Preparation:

Step 1: In a microwave oven safe glass bowl add milkmaid, marie biscuit powder, milk powder, Bournvita. Mix well. Select category BS45, enter recipe code & press start. Allow to cool. Make balls out of the mixture. Roll out the balls in the grated coconut. Keep in refrigerator for half an hour.

Category	Recipe-	Ingredients:	
BS46	SALSA NACHOS	Nachos	250 g
		Grated cheese	1 cup
		Pizza sauce	6 tbsp
		Green Bell Pepper	½ cup
		Cumins	½ tsp
		Salt as required	
		Chopped onion, tomato	2 cups

Method of Preparation:

Step 1: In a microwave oven safe flat plate add nachos, chopped onion, tomato, green bell pepper, pizza sauce & grated cheese. Mix well and Select category BS46, enter recipe code & press start

Category	Recipe-	Ingredients:	
BS47	PAPAYA SALAD	Papaya - Finely Shredded	250 g
		Garlic Cloves	4
		Green Chillies	1
		Jaggery	4 tbsp
		Lemon Juice	1 tsp
		Soy Sauce	1 tsp
		Peanuts - Roasted	2 tbsp
Method of Preparation:			
Step 1: Take a microwave oven safe flat glass bowl, add all ingredients, mix well and keep it on the turn table. Select category BS47, enter recipe code and press start. Chill & serve.			

Category	Recipe-	Ingredients:	
BS48	BETROOT SALAD	Beetroot (sliced)	250 g
		Saunf	1 tsp
		Coriander powder	1 tsp
		Lemon juice	1 tsp
		Pepper powder	½ tsp
		Salt to taste	
Method of Preparation:			
Step 1: Take a microwave oven safe flat glass bowl, add sliced beetroot. Keep the in the on the turn table. Select category BS48, enter recipe code and press start. After the oven beeps, remove and add saunf, coriander powder, pepper powder, salt & lemon juice. Toss well. Chill & serve.			

Category	Recipe-	Ingredients:	
BS49	CARROT, PEAS SALAD	Carrot	150 g
		Peas	100 g
		Pepper powder	1 tsp
		Lemon juice	1 tsp
		Salt to taste	
		Water if required	
Method of Preparation:			
Step 1: Take a microwave safe bowl add carrot & peas together. Add some water cover. Select category BS49, enter recipe code & press start. Add salt, lemon juice, pepper powder. Mix well & Serve.			

Category	Recipe-	Ingredients:	
BS50	TIRANGA SALAD	Grated carrot	1½ cup
		Grated radish	1½ cup
		Broccoli florets	1½ cup
		Olive	2
		Lemon juice	1 tsp
		Salt to taste	
Method of Preparation:			
Step 1: In a microwave oven safe flat glass dish arrange grated carrot first in the form of a band, then grated radish & then broccoli florets. Select category BS50, enter recipe code & press start. After the oven beeps, remove and add salt & lemon juice. Mix each layer separately. Take olive & cut into thin slices. Now make a flower at the center of the radish layer with olive slices, chill & serve.			

Category	Recipe-	Ingredients:	
BS51	DALIYA SALAD	Dalia	200 gr
		Coriander Leaves, Chopped	1 tbsp
		Mint Leaves, Chopped	1 tbsp
		Onion, Chopped	1 cup
		Tomato Chopped	½ cup
		Lemon Juice	1 tsp
		Olive Oil	2 tbsp
		Pepper Powder	1 tsp
		Cinnamon Powder	a pinch
		Salt To Taste	
		Water As Required	

Method of Preparation:

Step 1: Take a microwave oven safe bowl add dalia, water & few drops of oil. Select category BS51, enter recipe code & press start.

Step2: When the oven beeps, remove and add all ingredients, mix well and press start. Chill & serve.

Category	Recipe-	Ingredients:	
BS52	PASTA SALAD	Pasta	200 g
		Grated carrot	½ cup
		Chopped capsicum	½ cup
		Chopped spring onion	½ cup
		Sliced olives	Few
		Pepper powder	1 tsp
		Olive oil	2 tsp
		Vinegar	1 tsp
		Oregano (optional)	As per taste
		Water As Required	
		Salt to taste	

Method of Preparation:

Step 1: Take a microwave oven safe bowl add pasta, water & few drops of oil. Select category BS52, enter recipe code & press start. Wash the boiled paste under cold water to separate them.

Step 2: In another bowl take boiled pasta, add vegetable, salt, pepper powder, vinegar, curd, olive oil. Mix well and press start. Chill & serve.

STEAM COOK/FERMENTATION

Category	Recipe-	Ingredients:	
SF1	STEAM RICE	Soaked Rice	1½ cup
		Water as required	
Method of Preparation: Step1:- Take a microwave oven safe bowl, add rice and water, mix well. Place the bowl uncovered on the turntable in the oven, select category SF1, enter recipe code and press start. Step 2:- After beep, remove, mix smoothly and cover with lid and press start.			

Category	Recipe-	Ingredients:	
SF2	STEAM VEGETABLE	Broccoli Florets	½ cup
		Cauliflower Florets	½ cup
		Carrot (Lengthwise Chopped)	½ cup
		Red Bell pepper (Lengthwise Chopped)	½ cup
		Yellow Bell Pepper (Lengthwise Chopped)	½ cup
		Butter	2 tbsp
		Lime Juice	1 tsp
		Garlic Chopped	1 tsp
		Salt to taste	
Method of Preparation: Step1:- Take a microwave oven safe bowl, add all ingredients, mix well. Place the bowl with lid on the turntable in the oven, select category SF2, enter recipe code and press start. After beep, remove and Serve Hot.			

Category	Recipe-	Ingredients:	
SF3	STEAM SWEET CORN	Whole Sweet Corns	2
Method of Preparation: Step1:- Remove the husk until three layers remain. Arrange the sweet corn on the turntable, Select category SF3, enter recipe code & press start.(turn the corns upside down in between). When the oven beeps, remove and set to cool. Deseed and serve.			

Category	Recipe-	Ingredients:	
SF4	STEAM SWEET POTATOES	Whole Sweet Potatoes	2
Method of Preparation: Step1:- Pricks the sweet potatoes with fork and place it on the turntable in the oven, select category SF4, enter recipe code and press start. (Turn upside down in between). After beep, remove and set to cool. Peel the sweet potato cover and serve hot.			

Category	Recipe-	Ingredients:	
SF5	STEAM BROCCOLI	Broccoli Florets	2 cup
		Garlic Chopped	1 tsp
		Lemon Juice	1 tsp
		Olive oil	1 tbsp
		Salt to taste	
		Water	½ cup

Method of Preparation:

Step1:- Take a microwave oven safe bowl, add all ingredients, mix well. Place the bowl with lid on the turntable in the oven, select category SF5, enter recipe code and press start. After beep, remove and Serve Hot.

Category	Recipe-	Ingredients:	
SF6	STEAM FISH	Pomfret Large size	250 g
		Grated Coconut	1 cup
		Coriander Leaves paste	½ cup
		Mint Leaves paste	½ cup
		Green Chili Paste	1 tsp
		Garlic, Ginger Paste	1 tsp
		Lime Juice	1 tsp
		Rec Chili Powder	1 tsp
		Turmeric Powder	¼ tsp
		Oil As required	
		Salt To Taste	
		Banana Leaf	

Method of Preparation:

Take all ingredients other than pomfret in a mixing bowl, mix well and apply both sides to pomfret. Arrange pomfret in a half portion of banana leaf. Fold the other half banana leaf and close with teeth picks.

Step 1:- Take a wide glass bowl, add fish, cover the bowl with lid and place on the turntable in the oven. Select category SF6, enter recipe code and press start. Serve hot.

Category	Recipe-	Ingredients:	
SF7	STEAM SPROUTS	Bean Sprouts	2 cups
		Onion Chopped	1 cup
		Tomato Chopped	½ cup
		Green Chili Chopped	½ cup
		Red Chili Powder	1 tsp
		Lime Juice	1 tsp
		Chaat Masala	1 tsp
		Coriander Leaves for Garnish	1 tsp
		Salt to taste	¼ tsp
		Water as required	

Method of Preparation:

Step1:- Take a microwave oven safe bowl, add all ingredients, mix well. Place the bowl with lid on the turntable in the oven, select category SF7, enter recipe code and press start. After beep, remove and Serve Hot.

Category	Recipe-	Ingredients:	
SF8	STEAM IDLY	Idly Batter	200 g
<p>Method of Preparation:</p> <p>Step1:- Pour idly batter in lightly greased microwave safe idly stand. Pour some water in the bottom of the idly bowl and cover the bowl with lid. Place the bowl in the microwave oven, select category SF8, enter recipe code & press start. Remove After the beep & serve hot with sambar and coconut chutney.</p>			

Category	Recipe-	Ingredients:	
SF9	STEAM DOKHLA	Besan (Gram Flour)	2 cups
		Corn Flour	1 cup
		Sugar	½ cup
		Turmeric Powder	½ cup
		Citric Acid	1 tsp
		Soda-Bi-Carb	1 tsp
		Lemon Juice	1 tsp
		Mustard Seeds	1 tsp
		Green Chillies - Finely Chopped	¼ tsp
		Amchoor Powder	
		Salt To Taste	
		Oil As Required	
		Grated Coconut For Garnish	
		Coriander Leaves For Garnish	
		Water As Required	

Method of Preparation:

"Take gram flour, curd, water, salt, mix well into a batter. Cover it and set aside for 4 hours to marinate. Add green chillies, ginger paste, turmeric, lime juice, oil, soda-bi-carb and mix into a smooth batter.

Step 1: Pour into microwave oven safe lightly greased bowl, cover the bowl with lid and place in the microwave oven, select category SF9, enter recipe code and press start. For tempering use curry leaves, mustard seeds, oil, and green chillies. Garnish with coriander leaves and grated coconut. Serve with chutney."

Category	Recipe-	Ingredients:	
SF10	STEAM VEG- DIMSUM	Fillings :-	
		Beans	¼ cup
		Carrots Chopped	¼ cup
		Capsicum Chopped	¼ cup
		Citric Acid	¼ cup
		Soda-Bi-Carb	¼ cup
		Lemon Juice	1 tsp
		Mustard Seeds	1 tsp
		Green Chilies - Finely Chopped	1 tsp
		Amchoor Powder	1 tsp
		Salt To Taste	1 tsp
		Oil As Required	
		Grated Coconut For Garnish	
		Coriander Leaves For Garnish	
		Water As Required	
		For Dough:-	
		All Purpose Flour	1 cup
		Baking Powder	½ tsp
		Oil as required	
		Salt to taste	
		Water as required	

Method of Preparation:

Make the dough with flour, baking powder, salt, oil and water to a stiff dough, take a small portion of dough, roll it thin, Mix all filling ingredients, Spoon some filling in, and seal the edges to shape it like a dim sum. Step 1:- Arrange dim sum in a greased steamer plate and place the plate in a bowl. Pour some water in the bottom of bowl, cover with lid & keep it on the turntable.

Step 1:- Select category SF10, enter recipe code and press start. Serve hot.

Category	Recipe-	Ingredients:	
SF11	STEAM MODAK	Ingredients for stuffing;	
		2 cups Coconut, grated	¼ cup
		1 cup melted Jaggery	¼ cup
		¼ cup Milk	¼ cup
		½ tsp Elaichi powder	¼ cup
		2 cups Coconut, grated	¼ cup
		Ingredients for dough;	
		2 cups Rice flour	1 tsp
		1 cups Water	1 tsp
		2 tbsps Oil	1 tsp

Method of Preparation:

Boil the oil & water, add rice flour in it, mix well and set aside for 20 minutes. Take a Microwave oven safe bowl, add all the ingredients mentioned under stuffing mix well and set aside. Make balls of the rice dough. Make a small hollow in the center and place the stuffing in the middle. Now joint the open edges together and give it a shape like a whole garlic. Take a microwave oven safe wide bowl, pour one cup of water in it and cook for 2 minutes to get water boil.

Step 1:- Arrange the modak in microwave safe steam plates and place it in the hot water bowl, cover with lid and select category SF11, enter recipe code and press start. Set to cool and serve.

Category	Recipe-	Ingredients:	
SF12	STEAM VEG-DUMPLING	Boiled & Grated Potatoes	1 cup
		Grated Paneer	½ cup
		Chopped Spinach	½ cup
		Chopped Green Chili	1 tsp
		Chopped Garlic	1 tsp
		Baking Powder	½ tsp
		Maida	2 tbsp
		Nutmeg Powder	1 tsp
		Grated Cheese	1 tsp
		Pepper as per taste	
		Salt to taste	

Method of Preparation:

Step 1:- Mix all ingredients together and make 10-12 balls from it, place them in MWO steamer and select category SF12, enter recipe code and press start.

Category	Recipe-	Ingredients:	
SF13	STEAM MOMOS	Stuffing's:-	
		Cabbage	¼ cup
		Carrot	¼ cup
		Capsicum	¼ cup
		French Beans	¼ cup
		Onion Chopped	¼ cup
		Garlic Chopped	½ tsp
		Soya Sauce	1 tsp
		Oil as required	
		Pepper as per taste	
		Salt to taste	
		Dough :-	
		Maida	1 cup
		Oil as required	
		Salt to taste	
		Water as required	

Method of Preparation:

Make the dough with flour, salt, oil and water to a stiff dough, take a small portion of dough, roll it thin, Mix all filling ingredients, Spoon some filling in, and seal the edges to shape it like a momos. Step 1:- Arrange momos in a greased steamer plate and place the plate in a bowl. Pour some water in the bottom of bowl, cover with lid & keep it on the turntable. Select category SF13 enter recipe code, and press start. Serve hot.

Category	Recipe-	Ingredients:	
SF14	STEAMED KOTHIMBHIR VADI	Coriander Leaves Chopped	2 cup
		Besan	1 cup
		Roasted Peanut Powder	½ cup
		Coriander Powder	1 tsp
		Cumins Powder	1 tsp
		Red Chili Powder	1 tsp
		Turmeric Powder	¼ tsp
		Garlic, Ginger Paste	1 tsp
		Green Chili Paste	1 tsp
		Asafoetida	½ tsp
		Sesame Seeds e	3 tsp
		Oil as required	
		Sugar (optional)	
		Salt to taste	
		Water as required	

Method of Preparation:

Combine all ingredients, mix well and make a thick batter. Spread the batter in plain cotton cloth and fold it. Place the cloth on the turntable. Take a cup of water in a microwave oven safe bowl or glass and place just beside of cloth on the turntable.

Step 1:- Select category SF14, enter recipe code and press start. After beep, remove and set to cool.

When the Kothimbhir vadi is get cooled cut it in square or diamond shape. Serve hot.(if required shallow fry the kothimbhir vadi with 1 tbsp of oil in micro mode for 2 minutes).

Category	Recipe-	Ingredients:	
SF15	STEAM ASPARAGUS	Thin Asparagus 1½ inch sized	2 cup
		Rack Salt	½ tsp
		Water	1 cup
		Butter to serve	
		Hollandaise Sauce to Serve	

Method of Preparation:

Take a cup of water, salt and asparagus in a microwave oven safe bowl, mix well, cover the bowl with lid and place it on the turntable.

Step 1:- Select category SF15, enter recipe code and press start. After beep, remove and serve with batter and hollandaise sauce.

Category	Recipe-	Ingredients:	
SF16	STEAM GREEN STEW	Broccoli Florets	1 cup
		Asparagus Chopped	1 cup
		Spinach Leaves	1 cup
		Green Peas	½ cup
		Green Beans	½ cup
		Butter	1 tbsp
		Garlic Chopped	1 tsp
		Pepper powder	1 tsp
		Salt to taste	
		Water as required	

Method of Preparation:

Step 1:-Take a microwave oven safe bowl, add all ingredients, mix well, cover the bowl with lid and select category SF16, enter recipe code and press start.

Step 2:- After beep, remove and add water, mix well and press start. Serve hot.

Category	Recipe-	Ingredients:	
SF17	STEAM CAULIFLOWER	Cauliflower Florets	1 cup
		Butter	1 tbsp
		Salt to taste	
		Water as required	

Method of Preparation:

Step 1:-Take a microwave oven safe bowl, add all ingredients, mix well, cover the bowl with lid and select category SF17, enter recipe code and press start. After beep, remove and Serve hot.

Category	Recipe-	Ingredients:	
SF18	STEAMED PEAS	Peas	2 cup
		Butter	1 tbsp
		Black Pepper	1 tsp
		Salt to taste	
		Water as required	
		Coriander leaves for Garnish	

Method of Preparation:

Step 1:-Take a microwave oven safe bowl, add all ingredients other than coriander leaves, mix well, cover the bowl with lid and select category SF18, enter recipe code and press start. After beep, remove and garnish with coriander leaves. Serve hot.

Category	Recipe-	Ingredients:	
SF19	STEAMED BABY CORN	Baby Corns	2 cup
		Butter	1 tbsp
		Black Pepper	1 tsp
		Salt to taste	
		Water as required	

Method of Preparation:

Step 1:-Take a microwave oven safe bowl, add all ingredients, mix well, cover the bowl with lid and select category SF19, enter recipe code and press start. After beep, remove and Serve hot.

Category	Recipe-	Ingredients:	
SF20	YOGURT	Curd	250 ml
		Milkmaid	100 ml
		Fresh cream	200 ml
		Essence	¼ tsp
<p>Method of Preparation: "Step 1: Select category SF20 , enter recipe code] press start to pre heat the oven. Take a mixing bowl, add all ingredients mix well. Step 2: When the oven beeps, place the bowl in pre heated oven and press start."</p>			

Category	Recipe-	Ingredients:	
SF21	BREAD DOUGH	All-Purpose Flour	2 cups
		Warm Water	½ cup
		Active-Dry Yeast	2 tsp
		Unsalted Butter	1 tbsp
		Milk Powder	3 tbsp
		Sugar	1tsp
		Oil	2 tbsp
		Salt To Taste	
		Water As Required	
<p>Method of Preparation: Take warm water in a bowl, add dry yeast, sugar and 2 tsp flour, mix well and set it aside for 5 minutes. Take another mixing bowl, add maida, oil, salt, milk powder, butter and dry yeast water, mix well to make a smooth, soft dough. Punch the dough for 10 minutes. Set it aside for 15 minutes. Punch the dough again for 5 minutes. Set the dough batter in a bowl. Select category SF21 , enter recipe code & press start.</p>			

Category	Recipe-	Ingredients:	
SF22	PIZZA DOUGH BATTER	All Purpose Flour (Maida)	2 cups
		Salt	1 tsp
		Dry Yeast	2 tsp
		Sugar	1 tsp
		Oil	3 tsp
		Oregano	1 tsp
		Chili Flakes	1 tsp
		Water As Required	
<p>Method of Preparation: Take half a cup of warm water, add sugar, yeast and a pinch of flour, stir and cover. Keep aside for 5 minutes. Sieve the flour, add salt, chili flakes, oregano and oil, mix well, add the yeast water. Make smooth and soft dough using of water as required. Set it aside for 15 minutes. Roll out the dough. Place on adjusted baking try and prick with a fork. Cover and leave in the oven select category SF22 , enter recipe code & press start.</p>			

Category	Recipe-	Ingredients:	
SF23	DOSA BATTER	Parboiled Rice	½ cup
		Regular Rice	½ cup
		Urad Dal	¼ cup
		Methi Seeds	½ tsp
		Poha	3 tbsp
		Water For Soaking	
		Water For Grinding	
		Salt As Required	
		Oil As Required	

Method of Preparation:

Soak & make a smooth batter with all above ingredients and take the batter in a large bowl, place it in the oven and select categorySF23 , enter recipe code & press start.

Category	Recipe-	Ingredients:	
SF24	JALEBI BATTER	All Purpose Flour	2 cup
		Besan	4 tbsp
		Turmeric Powder	1/8 tsp
		Baking Soda	1 pinch
		Water	2 cup

Method of Preparation:

Soak & make a smooth batter with all above ingredients and take the batter in a large bowl, place it in the oven and select categorySF24 , enter recipe code & press start.

Category	Recipe-	Ingredients:	
SF25	IDLI BATTER	Parboiled Rice	½ cup
		Regular Rice	½ cup
		Urad Dal	¼ cup
		Methi Seeds	½ tsp
		Poha	3 tbsp
		Water For Soaking	
		Water For Grinding	
		Salt As Required	
		Oil As Required	

Method of Preparation:

Soak & make a smooth batter with all above ingredients and take the batter in a large bowl, place it in the oven and select categorySF25 , enter recipe code & press start.

Category	Recipe-	Ingredients:	
SF26	APPAM BATTER	Raw rice	2 cup
		Par boiled rice	2 cup
		Fenugreek seeds	2 tsp
		Urad dal	5 tbsp
		Coconut milk	6 tbsp
		Cooking soda	1 tsp

Method of Preparation:

Soak & make a smooth batter with all above ingredients and take the batter in a large bowl, place it in the oven and select categorySF26 , enter recipe code & press start.

Category	Recipe-	Ingredients:	
SF27	NAAN DOUGH	All Purpose Flour	1 cup
		Wheat Flour	¼ cup
		Sugar	1 tsp
		Instant Yeast	½ tsp p
		Water As Required	
		Curd	2 tbsp
		Butter, Melted	1 tbsp
		Salt As Required	

Method of Preparation:

Take warm water in a bowl, add dry yeast, sugar, mix well and cover with lid, set it aside for 5 minutes. Take another mixing bowl, Combine all the ingredients, including the yeast mixture and knead into a smooth, soft dough using enough water. Cover with a damp cloth and place it in the oven, Select category SF27 , enter recipe code & press start.

Category	Recipe-	Ingredients:	
SF28	DHOKLA BATTER	Gram Flour	1½ cup
		Rava (Optional)	1 tbsp
		Ginger-Green Chilies Paste	3 tsp
		Turmeric Powder	¼ tsp
		Asafoetida	a pinch
		Baking Soda	1 tsp
		Lime Juice	1 tsp
		Water As Required	
		Salt To Taste	

Method of Preparation:

Combine all ingredients to make a smooth batter and pour the batter in a mixing bowl. Place it in the oven and select category SF28 , enter recipe code & press start.

Category	Recipe-	Ingredients:	
SF29	KEEP WARM	Any Cooked Food	

Method of Preparation:

Place the cooked food bowl in the oven and select category SF29 , enter recipe code & press start.

PANEER/GHEE/ CURD

Category	Recipe-	Ingredients:	
PG01	PANEER	Milk	6 cup
		Curd	¼ cup
<p>Method of Preparation:</p> <p>Step 1: Take a microwave oven safe bowl, add all the ingredients and mix well. Select category PG01, enter recipe code & press start. After the beep, remove and strain the milk in the cheesecloth. Drain the whey. Collect the cheesecloth together with the coagulated milk shredded tightly. Place it on a plate and keep a heavy weight on top of the cheesecloth. Check after 30-40 minutes. the paneer would be set. Once warm or cooled cut paneer into cubes or any shape.</p>			

Category	Recipe-	Ingredients:	
PG02	MASALA PANEER	Milk	500 ml
		Curd	2 tbsp
		Coriander powder	1 tbsp
		Jeera powder	1 tsp
<p>Method of Preparation:</p> <p>Step 1: Take a microwave oven safe glass bowl add all ingredients and mix well. Select category PG02, enter recipe code & press start. When the oven beeps, remove and strain and press in a muslin cloth.</p>			

Category	Recipe-	Ingredients:	
PG03	GHEE	butter globules	3 cup
<p>Method of Preparation:</p> <p>Step 1: Take a microwave oven safe deep glass bowl, add butter globules, mix well, cover the bowl with lid and select category PG03, enter recipe code & press start. After the beep, remove and set to cool and store in a glass jar.</p>			

Category	Recipe-	Ingredients:	
PG04	CURD	Milk	8 cup
		Curd	¼ cup
<p>Method of Preparation:</p> <p>Step 1: Take a microwave oven safe deep glass bowl, add all ingredients and mix well. Select category PG04, enter recipe code & press start.</p>			

KITCHEN ASSISTANCE

Category	Recipe-	Ingredients:	
AS1	LEMON SQUEEZE	Whole Lemon	2 no's
Method of Preparation: Step 1:-Place the lemons on the turntable in the oven, select category AS1, enter recipe code and press start. After beep, take the lemons and cut it in to half, now squeeze the lemon juice.			

Category	Recipe-	Ingredients:	
AS2	FRESH APPLE	Apples	1 no's
Method of Preparation: Step 1:-Place the apple on the turntable in the oven, select category AS2, enter recipe code and press start. After beep, remove, cut in to pieces and serve.			

Category	Recipe-	Ingredients:	
AS3	FRESH AMLA	Amla	100 g
Method of Preparation: Step 1:-Place the amla on the turntable in the oven, select category AS3, enter recipe code and press start. After beep, remove, cut in to pieces and serve.			

Category	Recipe-	Ingredients:	
AS4	GARLIC PEEL	Garlic Petals with skin	100 g
Method of Preparation: Step 1:-Place the garlic petals on the turntable in the oven, select category AS4, enter recipe code and press start. After beep, remove garlic petal skin and use.			

Category	Recipe-	Ingredients:	
AS5	TEAR FREE ONIONS	Onions	100 g
Method of Preparation: Step 1:-Place the onions on the turntable in the oven, select category AS5, enter recipe code and press start. After beep, remove and cut in to pieces.			

Category	Recipe-	Ingredients:	
AS6	ORANGE SQUEEZE	Orange	150 g
Method of Preparation: Step 1:-Place the orange on the turntable in the oven, select category AS6, enter recipe code and press start. After beep, take the orange and peel the top cover and serve.			

Category	Recipe-	Ingredients:	
AS7	MANGO SQUEEZE	Mango	150 g
Method of Preparation: Step 1:-Place the mango on the turntable in the oven, select category AS7, enter recipe code and press start. After beep, remove the mango, cut it in to pieces and serve.			

Category	Recipe-	Ingredients:	
AS8	FRESH ALOE VERA	Aloe vera	100 g
Method of Preparation: Step 1:-Place the Aloe vera on the turntable in the oven, select category AS8, enter recipe code and press start. After beep, take the aloe vera and cut it in to half, use aloe vera paste for skin or hair or health as well.			

Category	Recipe-	Ingredients:	
AS9	FANCY PAPAD CONES	Smooth Round Papad	8 no's
Method of Preparation: Take A4 size paper, cut the paper in to 4 equal sized and fold all paper in to triangular shape cones. Repeat the same for another 4 papads. Step 1:- Smoothly cut the papad half and fold it in to cone shape. Arrange all papads in paper cones place it on the oven, select category AS9, enter recipe code and press start. After beep, remove the papads from paper cones and serve fancy cone papads.			

Category	Recipe-	Ingredients:	
AS10	FANCY PAPAD ROLLS	Smooth Round Papad	8 no's
Method of Preparation: Step1:- Make papad roll and keep it in a paper and roll it. Repeat the same for all another papads and place it on the turntable in the oven. Select category AS10, enter recipe code and press start. After beep, remove the papads from papers and serve fancy roll papads.			

Category	Recipe-	Ingredients:	
AS11	CHINNAMON ROAST	Cinnamon sticks	100 g
Method of Preparation: Step 1:- Place the cinnamon sticks on the turntable in the oven, select category AS11, enter recipe code and press start. After beep, take the roasted cinnamon sticks, put it in a chutney pot, and grind it to make powder of it. Use a pinch of cinnamon powder in curries. It will gives you good taste as well as cinnamon powder increase the knowledge as well.			

Category	Recipe-	Ingredients:	
AS12	CASHEW ROAST	Cashew nuts	100 g
Method of Preparation: Step 1:- Take a microwave oven safe glass bowl, add cashew nuts in it and place on the turntable in the oven, select category AS12, enter recipe code and press start. After beep, remove serve. Cashews are one of the lowest-fiber nuts, Cashews packed with vitamins, minerals and antioxidants. These include vitamins E, K, and B6, along with minerals like copper, phosphorus, zinc, magnesium, iron, and selenium, all of which are important for maintaining good bodily function.			

Category	Recipe-	Ingredients:	
AS13	ALMONDS ROAST	Almonds	100 g
Method of Preparation: Step 1:- Take a microwave oven safe glass bowl, add almonds in it and place on the turntable in the oven, select category AS13, enter recipe code and press start. After beep, remove serve. Almonds having high-quality proteins with high levels of bioactive molecules, which may help prevent cardiovascular disease.			

Category	Recipe-	Ingredients:	
AS14	FRESH HALDI MILK	Milk	100 g
		Turmeric Powder	¼ tsp
		Pepper Powder	¼ tsp
		Sugar as required (optional)	
Method of Preparation: Step 1:- Take a microwave oven safe glass bowl, add all ingredients, mix well and Select category AS14, enter recipe code and press start. After beep, remove serve. Haldi milk help to build immunity by reducing allergies, purifying blood. Detoxifying the liver and promoting oral health.			

Category	Recipe-	Ingredients:	
AS15	BADAM KESAR MILK	Milk	100 g
		Almonds (soaked) paste	1 tsp
		Saffron soaked in milk	Few
		Cardamom Powder	A pinch
		Sugar as required	
Method of Preparation: Step 1:- Take a microwave oven safe glass bowl, add all ingredients, mix well and Select category AS15, enter recipe code and press start. After beep, remove and serve. Badam kesari milk used as medicine for Asthma, cough or cold to loosen the phlegm.			

Category	Recipe-	Ingredients:	
AS16	COCONUT WHITE SEPARATION	Broken Coconut	100 g
Method of Preparation: Step 1:- Place the broken coconut on the turntable in the oven, select category AS16, enter recipe code and press start. After beep, take the coconut and separate coconut white from shell easily with knife.			

Category	Recipe-	Ingredients:	
AS17	SESAME SEEDS ROAST	Sesame Seeds	100 g
Method of Preparation: Step 1:- Take a microwave oven safe glass bowl, add sesame seeds in it and place on the turntable in the oven, select category AS17, enter recipe code and press start. After beep, remove and use.			

Category	Recipe-	Ingredients:	
AS18	CORIANDER SEEDS ROAST	Coriander Seeds	100 g
Method of Preparation: Step 1:- Take a microwave oven safe glass bowl, add coriander seeds in it and place on the turntable in the oven, select category AS18 , enter recipe code and press start. After beep, remove and use.			

Category	Recipe-	Ingredients:	
AS19	AJWAIN ROAST	Ajwain	100 g
Method of Preparation: Step 1:- Take a microwave oven safe glass bowl, add Ajwain in it and place on the turntable in the oven, select category AS19 , enter recipe code and press start. After beep, remove and use.			

Category	Recipe-	Ingredients:	
AS20	SALTY JAVAS	Javas	100 g
		Salt water as required	
Method of Preparation: Step 1:- Take a microwave oven safe glass bowl, add javas and salt water in it and place on the turntable in the oven, select category AS20, enter recipe code and press start. After beep, remove and store it in airtight jar.			

Category	Recipe-	Ingredients:	
AS21	FENNEL ROAST	Fennel	100 g
Method of Preparation: Step 1:- Take a microwave oven safe glass bowl, add fennel in it and place on the turntable in the oven, select category AS21, enter recipe code and press start. After beep, remove and store it in airtight jar.			

Category	Recipe-	Ingredients:	
AS22	TAMARIND PULP	Tamarind	100 g
		Water	1 cup
Method of Preparation: Step 1:- Take a microwave oven safe glass bowl, add tamarind and water in it and place on the turntable in the oven, select category AS22, enter recipe code and press start. After beep, remove and use the tamarind pulp.			

Category	Recipe-	Ingredients:	
AS23	SLICED COCONUT ROAST	Coconut Sliced lengthwise	100 g
Method of Preparation: Step 1:- Take a microwave oven safe glass bowl, add coconut slices in it and place on the turntable in the oven, select category AS23 , enter recipe code and press start. After beep, remove and use.			

Category	Recipe-	Ingredients:	
AS24	FENUGREEK SEEDS POWDER	Fenugreek Seeds	100 g
Method of Preparation: Step 1:- Take a microwave oven safe glass bowl, add fenugreek seeds in it and place on the turntable in the oven, select category AS24 , enter recipe code and press start. After beep, remove and grind for powder.			

Category	Recipe-	Ingredients:	
AS25	KHUS KHUS ROAST	Khus Khus	100 g
Method of Preparation: Step 1:- Take a microwave oven safe glass bowl, add khus khus in it and place on the turntable in the oven, select category AS25 , enter recipe code and press start. After beep, remove and use.			

Category	Recipe-	Ingredients:	
AS26	HEALTHY RAGI JAVA	Ragi Flour	100 g
		Water as required	
		Salt as required	
Method of Preparation: Step 1:- Take a microwave oven safe glass bowl, add ragi and water, mix well, mix well and place on the turntable in the oven, select category AS26, enter recipe code and press start. Step 2:- After beep, remove and add salt, mix well and press start. Ragi java Helps in Weight Loss and Raagi lowers your blood sugar levels in the body by activating insulin.			

Category	Recipe-	Ingredients:	
AS27	HEALTHY JOWAR PORRIDGE	Jowar Flour	100 g
		Water as required	
		Salt as required	
Method of Preparation: Step 1:- Take a microwave oven safe glass bowl, add Jowar and water, mix well and place on the turntable in the oven, select category AS27 , enter recipe code and press start. After beep, remove and add salt, mix well and press start. Jowar is a high end source of phosphorus, calcium, protein and fibre. The presence of iron and copper helps regulate proper blood circulation, which fuels cell growth, hair repair and enhances overall functioning of the body.			

Category	Recipe-	Ingredients:	
AS28	LEMON RICE	Rice Soaked	1½ cup
		Urad Dal	2 tsp
		Chana Dal	2 tsp
		Dry Red Chillies Broken	3
		Green Chillies slitted	3
		Lemon Juice as required	
		Mustard Seeds	1 tsp
		Turmeric Powder	¼ tsp
		Peanuts	½ cup
		Curry Leaves	few
		Salt to taste	
		Water as required	

Method of Preparation:

Step 1:- Take a microwave oven safe glass bowl, add all ingredients other than lemon juice, salt. Mix well and place on the turntable in the oven, select category AS28, enter recipe code and press start.

Step 2:- After beep, remove and add salt, lemon juice, mix well and press start. Serve hot.

Category	Recipe-	Ingredients:	
AS29	ONION ROAST	Onion Chopped Lengthwise	150 g

Method of Preparation:

Step 1:- Take a microwave oven safe glass bowl, add onions in it and place on the turntable in the oven, select category AS29, enter recipe code and press start. After beep, remove and use.

Category	Recipe-	Ingredients:	
AS30	FENUGREEK LEAVES DRIED	Fenugreek Leaves (Chopped in to small)	150 g

Method of Preparation:

Step 1:- Take a microwave oven safe glass bowl, add fenugreek leaves in it and place on the turntable in the oven, select category AS30, enter recipe code and press start. After beep, remove and use it like Kasoori methi. Fenugreek leaves beneficial for treating poor liver functions and diabetes.

Category	Recipe-	Ingredients:	
AS31	MILK PASTEURIZE	Milk	2 cup

Method of Preparation:

Step 1:- Take a microwave oven safe glass bowl, add milk in it and place on the turntable in the oven, select category AS31, enter recipe code and press start. Pasteurization also increases the shelf life of milk.

KID'S SPECIAL

Category	Recipe-	Ingredients:	
SP01	BREAD PIZZA	Bread Slices	4
		Capsicum Chopped	1 cup
		Onion Chopped	1 cup
		Pizza Sauce	3 tbsp
		Grated Cheese	4 cubes
		Butter	2 tbsp
		Chili Flakes	Few
<p>Method of Preparation: Arrange the bread slice on the grill mesh rack and apply butter, pizza sauce, chili flakes over it top with chopped capsicum, onion. Pour grated cheese over toppings and place it in the oven.</p> <p>Step 1:- Select category SP01, enter recipe code and press start. After beep, remove and cut in to pieces and serve hot.</p>			

Category	Recipe-	Ingredients:	
SP02	RAVA UPMA	Roasted Rava (Suji)	2 cup
		Potato Finely Chopped	½ cup
		Chopped Tomato	½ cup
		Carrot Grated	½ cup
		Onion, Chopped	1 cup
		Green Chillies Finely Chopped	2
		Channa Dal	½ tbsp
		Urad Dal	½ tbsp
		Mustard Seeds	¼ tsp
		Jeera	½ tsp
		Green Peas	¼ cup
		Cashew	½ tbsp
		Ghee	½ tbsp
		Turmeric	a pinch
		Green Coriander For Garnish	
		Coconut Grated For Garnish	
		Water	
<p>Method of Preparation:</p> <p>"Step 1: Take a microwave oven safe bowl, add all ingredients other than rava, tomato, cashew, coconut, coriander, water, mix well and select category SP02, enter recipe code & press start.</p> <p>Step 2: When the oven beeps, remove and add all the remaining ingredients other than coconut, coriander and mix well. Cover the bowl with a lid, place it in the microwave oven, and press start. Remove, garnish with coconut and coriander. Serve hot."</p>			

Category	Recipe-	Ingredients:	
SP03	STIR FRIED OATS	Oats	2½ cup
		Raisins	Few
		Flour	1½ tbsp
		Cinnamon	3 stick
		Sugar	2 tsp
		Butter As Required	
		Salt To Taste	
		Water As Required	

Method of Preparation:

"Step 1: Take a microwave oven safe bowl; add all ingredients other than raisins, water and flour. Mix well. Select category SP03, enter recipe code and press start.

Step 2: When the oven beeps, remove and add the remaining ingredients and mix well and press start. Serve hot."

Category	Recipe-	Ingredients:	
SP04	TEA	Milk	4 cup
		Tea Powder	3 tsp
		Sugar To Taste	
		Water As Required	

Method of Preparation:

"Step 1: In a microwave oven safe bowl, add all ingredients other than sugar, mix well and select category SP04, enter recipe code and press start.

Step 2: When the oven beeps, remove and add sugar, mix well and press start. Serve hot."

Category	Recipe-	Ingredients:	
SP05	POHA	Poha	3 cup
		Green Peas	¾ tbsp
		Chana Dhal	1½ tsp
		Urad Dhal	1½ tsp
		Onions (Chopped)	2
		Green Chili (Small Chopped)	3
		Carrot (Chopped)	3 tbsp
		Turmeric Powder	¼ tsp
		Cumin Seeds	1 tsp
		Salt To Taste	
		Oil As Required	
		Grated Coconut For Garnish;	
		Fresh Coriander For Garnish;	

Method of Preparation:

"Step 1: Take a microwave oven safe bowl; add all the ingredients other than pohe, salt, sugar, lime and garnish ingredients. mix well and select category SP05, enter recipe code and press start.

Step 2: When the oven beeps, remove and add the remaining ingredients other than garnish ingredients, mix well, cover the bowl with lid and place it in the microwave oven and press start. Remove, garnish with coriander and grated coconut. Serve hot."

Category	Recipe-	Ingredients:	
SP06	SABUDANA KICHDI	Sabudana (Soaked)	3 cup
		Ground Nut Powder	1½ cup
		Chopped Green Chillies	4
		Boiled & Peeled Potato	1 cup
		Oil	2 tbsp
		Hing	a pinch
		Cumin Seeds	¾ tsp
		Sugar	1½ tsp
		Lime Juice	¾ tsp
		Salt To Taste	

Method of Preparation:

"Step 1: Take a microwave oven safe bowl; add all the ingredients other than sabudana, salt, sugar and lime. Mix well and select category SP06, enter recipe code and press start.

Step 2: When the oven beeps, remove and add the remaining ingredients and mix well. Cover the bowl with lid, place it in the microwave oven, and press start. Remove and mix well and serve hot."

Category	Recipe	Ingredients:	
SP07	OMLETTE	Eggs – Beaten	4
		Onion - Finely Chopped	2
		Green Chillies - Finely Chopped	1 tsp
		Red Chilli Powder	1 tsp
		Oil	3 tsp
		Coriander Leaves For Garnish	
		Salt To Taste	
Method of Preparation:			
"Step 1: Take a microwave oven safe bowl; add all the ingredients other than egg and coriander leaves. Mix well and select categorySP07, enter recipe code and press start.			
Step 2: When the oven beeps, remove and add the beaten eggs, but not the coriander leaves, mix well and press start. Remove, garnish with coriander leaves and serve			

Category	Recipe-	Ingredients:	
SP08	VEGETABLE PULAO	Basmati rice	1½ cup
		Gobhi	½ cup
		Matar	½ cup
		French beans	½ cup
		Red chilli powder	1 tsp
		Gajar	½ cup
		Jeera	1 tsp
		Laung	Few
		tej patta	3
		garam masala	1 tsp
		Water as required	
Method of Preparation: Step 1: Take a microwave oven safe bowl, add oil, jeera, laung, tej patta & all vegetables and mix well. SelectcategorySP08, enter recipe code and press start.			
Step 2: When the oven beeps, remove and add rice, water, salt, garam masala, red chilli powder, mix well and press start. Step 3: After the oven beeps, mix well and press start. Serve hot.			

Category	Recipe-	Ingredients:	
SP09	EGG BHURJI	Eggs	4
		Onion, chopped	1½ cup
		Green Chilli, chopped	1 tsp
		Turmeric Powder	¼ tsp
		Cumins	1tsp
		Chopped tomato	½ cup
		Garlic paste	1 tsp
		Red chilli powder	1 tsp
		Garam masala	1 tsp
		Oil as required	
		Salt to taste	

Method of Preparation:

Step 1: Take a microwave oven safe bowl, add all ingredients other than eggs, mix well and select category SP09, enter recipe code & press start.

Step 2: Remove After the beep, add beaten eggs, mix well and press start.

Step 3: After the beep, remove, mix well and press start. Serve hot.

Category	Recipe-	Ingredients:	
SP10	VEGETABLE CHAT	Sev	¼ cup
		Peanuts - Roasted & Crushed	¼ cup
		Boiled Potato - Diced Into Small Cubes	¼ cup
		Chick Peas (Kabuli Channa) – Boiled(Optional)	¼ cup
		Corn Kernel – Boiled	¼ cup
		Tomato - Chopped Finely	¼ cup
		Onion - Chopped Finely	1
		Green Chilli - Chopped Finely	2
		Fresh Coriander Leaves - Chopped	½ tbsp
		Chaat Masala Powder (Optional)	1 tsp
		Red Chilli Powder	½ tsp
		Lemon Juice	½ tsp
		Salt To Taste	

Method of Preparation:

Step 1: Take a Microwave oven safe bowl, combine all the ingredients, mix them well, keep bowl on the turn table and select category SP10, enter recipe code & press start. Remove and serve .

Category	Recipe-	Ingredients:	
SP11	VEGETABLE PASTA	Pasta	2 cup
		Chopped Tomatoes	½ cup
		Broccoli Florets	½ cup
		Sliced Carrots	½ cup
		Chopped Capsicum	½ cup
		Sliced Squash	½ cup
		Minced Fresh Basil	1 tbsp
		Thyme	1 tsp
		Fresh Oregano	1 tbsp
		Garlic, Ginger Paste	1 tsp
		Pepper Powder	1 tsp
		Grated Cheese for Garnish	2 tbsp
		Salt to taste	
		Water as required	

Method of Preparation:

Step1:-Take a microwave oven safe bowl, add pasta and water, mix well and place it in the oven, select SP11, enter recipe code and press start.

Step 2:- . After beep, remove and add all remaining ingredients, mix well, press start. Serve Hot.

Category	Recipe-	Ingredients:	
SP12	KALAKAND	Condensed Milk	1 cup
		Crumbled Paneer	1½ cup
		Milk	¾ cup
		Cardamom Powder	½ tsp
		Nuts For Garnish	Few

Method of Preparation: Step 1: Take a microwave oven safe bowl, add all ingredients other than cardamom powder, nuts, mix well and select category SP12, enter recipe code and press start. After the beep, remove and add cardamom powder, mix smoothly and garnish with nuts, cut it into desired shapes. Serve warm

Category	Recipe-	Ingredients:	
SP13	APPLE CUSTARD	Apple Slices	2 cup
		Custard Powder	2½ tbsp
		Sugar	2½ tbsp
		Milk	2½ cup

Method of Preparation: Take a microwave oven safe bowl, Add all ingredients other than apples, mix well and select category SP13, enter recipe code & press start. After the beep, remove and add apples, mix well, set aside to cool. Serve warm or cool.

Category	Recipe-	Ingredients:	
SP14	BROWNIE	Flour – Sifted	1½ cup
		Margarine	2 tbsp
		Sugar	1½ cup
		Baking Powder	1 tsp
		Cocoa Powder	¾ cup
		Walnuts	½ tbsp
<p>Method of Preparation: Mix the margarine and sugar in a mixing bowl until the sugar is completely dissolved. Add cocoa powder, flour, nuts, baking powder and mix well until smooth. Pour into a lightly greased flat glass bowl. Place in the microwave oven, select category SP14, enter recipe code and press start. Remove, allow to cool and serve.</p>			

Category	Recipe-	Ingredients:	
SP15	GAJAR HALWA	Carrots (Grated)	3 cup
		Kawa (Mawa Grated)	1cup
		Sugar	2 cup
		Milk Condensed	1 cup
		Milk	1 cup
		Cardamoms	Few
		Pistachio Flakes (Almonds)	Few
		Ghee As Required	
		Raisins	Few
<p>Method of Preparation: "Step 1: Take a microwave oven safe bowl, add all the ingredients other than milk, condensed milk, cardamom, flakes and raisins and mix well. Select category SP15, enter recipe code & press start. Step 2:When the oven beeps, remove and add the remaining ingredients, mix well and press start."</p>			

Category	Recipe-	Ingredients:	
SP16	TOMATO SOUP	Tomatoes – Large	5
		Mint Leaves	Few
		Salt & Pepper To Taste	
<p>Method of Preparation: Step 1: Keep tomatoes in a microwave oven safe bowl; add all ingredients and mix well. Select category SP16, enter recipe code and press start. Remove After the oven beeps, when cool; blend the tomatoes in a mixer. Strain and serve hot.</p>			

Trouble shooting

Normal	
Microwave oven interfering TV reception	Radio and TV reception may be interfered when microwave oven operating. It is similar to the interference of small electrical appliances, like mixer, vacuum cleaner, and electric fan. It is normal.
Dim oven light	In low power microwave cooking, oven light may become dim. It is normal.
Steam accumulating on door, hot air out of vents	In cooking, steam may come out of food. Most will get out from vents. But some may accumulate on cool place like oven door. It is normal.
Oven started accidentally with no food in.	It is forbidden to run the unit without any food inside. It is very dangerous.

Trouble	Possible Cause	Remedy
Oven can not be started.	(1) Power cord not plugged in tightly.	Unplug. Then plug again after 10 seconds.
	(2) Fuse blowing or circuit breaker works.	Replace fuse or reset circuit breaker (repaired by professional personnel of our company)
	(3) Trouble with outlet.	Test outlet with other electrical appliances.
Oven does not heat.	(4) Door not closed well.	Close door well.

FREQUENTLY ASKED QUESTION

QUESTION	ANSWER
Can I use a rack in my microwave oven so that I may reheat or cook in two rack positions at a time?	<p>It is recommended that while using the microwave mode to cook or reheat, place food on the turn table only.</p> <p>The metal rack provided along with the microwave oven (*Select models) is not to be used in the microwave mode. Only use the rack that is supplied with your microwave oven in the grill, combination or convection mode.</p> <p>Use of any other rack can result in poor cooking performance and/or arcing and may damage your oven.</p>
Can I use either metal or aluminum pans in my microwave oven?	<p>Usable metal includes aluminum foil for shielding (use small, flat pieces).</p> <p>Never allow metal to touch the walls or door.</p>
Sometimes the door of my microwave oven appears wavy. Is this normal?	This appearance is normal and does not affect the operation of your oven.
What are the humming noises I hear when my microwave oven is operating?	This is the sound of the transformer when the magnetron tube cycles on and off.
Why does the dish become hot when I microwave food in it?	<p>As the food becomes hot, it will conduct the heat to the dish. Use hot pads to remove food after cooking.</p> <p>The dish may not be microwave safe.</p>
What does standing time mean?	Standing time means that food should be left in the oven for a short period of time after the cooking is over which allows the cooking to finish
Can I pop popcorn in my microwave oven? How do I get the best results?	<p>Yes. Pop packaged microwave popcorn following manufactures guideline or use the pre programmed popcorn pad.</p> <p>Do not use regular paper bags.</p> <p>Use the listening test by stopping the oven as soon as the popping slows to a pop every 1 to 2 secs. Do not try to repop unpopped kernels.</p>
Why does steam come out of the air exhaust vent?	Steam is normally produced during cooking. The microwave oven has been designed to vent this steam out the top vent.

MICROWAVE OVEN WARRANTY

The Godrej Microwave Oven comes with FOUR years warranty on the magnetron and a ONE year warranty (except for plastic parts, glass components and decorative strips, knobs etc.) against defective material or workmanship on all components of the microwave oven. Godrej & Boyce Mfg. Co. Ltd. Appliance Division undertakes repairs, free of charge during the warranty period.

INSTRUCTIONS FOR THE CUSTOMER

1. Kindly ensure that the dealer fills the warranty details correctly and completely.
2. You should retain the warranty page for record and produce the same in the event of any warranty repairs.
3. In the event of a defect developing in the product, contact the nearest authorised Godrej & Boyce Service Centre for obtaining warranty service and inform the defect, model details and Serial No.

TERMS AND CONDITIONS

1. Repairs and replacement of parts will be carried out through the authorised customer service centre.
2. For units installed beyond the municipal limits of the jurisdiction of the authorised customer care centre all expenses incurred in collecting the units or parts thereof from the company's customer care centre, as well as expenses incurred with depositing of service personnel/technician's towards conveyance and other incidents will be borne by the customer.
3. The concerned customer care centre will advise the customer whether to effect the repair at site or at the customer care centre.
4. While the company will make every effort to carry out the repairs at the earliest, it however is made expressly clear that the company is under no obligation to do so in a specified period of time.
5. The company or its authorised customer care centre/service dealer reserves the right to retain any parts, components replaced at its discretion.
6. Warranty does not cover accessories to the equipment.
7. The warranty is confined to the first purchaser of MWO only and non-transferable.
8. Call registered with the centralised helpline/authorised service centre, where in only cleaning of the unit/parts in the unit due to dust accumulation on portions of the units are not to be considered as defects.
9. **In case of any damages to the product, customer abuse, repairs by unauthorised personnel & misuse detected by the authorised service centre personnel, the warranty conditions are not applicable.**
10. If any coloured internal or external components are replaced, effort will be made to ensure that the shades match with the original or other components. However, the replaced shades, pattern, tints may vary from the customer's unit due to usage of the unit. Any matching components changed at customer's request will be charged, except the component which is actually needed.
11. **The unit shall be operated with variation +/-5% of the rated voltage. Fluctuation beyond specified tolerance will not be covered under warranty. Customer shall not operate the product below 210V under any circumstances.**
12. Parts not covered - Main door, Glass, Bulb, Rubber, Plastic Components.
13. This warranty does not cover any type of painting, plating including rusting etc. or defects thereof.
14. **The Appliance or any part thereof is subjected to neglect, abuse or misuse, tampering, alteration, accident, fire, floods or other acts of God, or Damage by rodents or insects, the COMPANY is not responsible for any damage caused to the appliance & Shall not be liable for any consequential loss or compensation. nor refund of purchase price or replacement of the appliance.**

Godrej & Boyce Mfg. Co. Ltd.- Appliance Division

MODEL NO.

WARRANTY DETAILS

UNIT SR. NO.

UNIT SR. NO.

CUSTOMER'S NAME & ADDRESS _____ _____ _____
TEL. _____

DEALER'S NAME & ADDRESS _____ _____ _____
TEL. _____

Customer's Signature:

Dealer's Signature:

This card is valid only if it is filled in and stamped by our authorised dealer on the date of purchase.

Warranty is Void If:

1. The warranty card is not completed properly at the time of purchase.
2. The completed warranty card is not presented to the authorised personnel at the time of service of the product.
3. The microwave is not operated according to instructions given in the 'User Guide'.
4. Defects are caused by improper or reckless use, which shall be determined by the company personnel.
5. Any repair work earned out by persons other than authorised company personnel.
6. Defects caused beyond control like abnormal voltage, acts of God, or while in transit to service centre or purchaser's residence.
7. The warranty is not valid in case the serial number is deleted, defaced or altered.
8. Damage to the microwave or any parts due to transportation or shifting is not covered by the warranty.
9. The warranty automatically expires after 12 month of original date of purchase, even if the microwave may not be in use for any time for whatever reasons during the warranty period.

GODREJ & BOYCE MFG. CO. LTD., Appliances Division

Branch	Address
Ahmedabad	4th Floor, APM Shopping Mall Near IOCL Petrol Pump, Shyamal-Karnavati, 100 ft. Road, Satellite, Ahmedabad - 380 015
Bangalore	3rd Floor, The Karnataka Film Chamber of Commerce Bldg. 28, 1st Main, Crescent Road, High Grounds Nr. Shivanand Circle, Bangalore - 560 001
Bhopal	217, Zone I, M.P. Nagar, Beh. Jyoti Talkies, Bhopal - 462 011
Bhubaneswar	Highway Complex, NH-5, Rudrapur, Bhubaneswar - 752 101
Chandigarh/Mohali	Plot No. A-40, Phase VIII-A, Industrial Area, Mohali - 160 059
Chennai	No. 1, Sidco Industrial Estate, Ambattur, Chennai - 600 098
Coimbatore	No. 585 - 590 3rd Floor, Sathya Towers, DB Road, R S Puram, Coimbatore - 641002
Delhi	Godrej Bhavan, 2nd Floor, Shershah Suri Marg, Mathura Road, Okhla, New Delhi - 110 065
Faridabad	Godrej Bhavan, 2nd Floor, Shershah Suri Marg, Mathura Road, Okhla, New Delhi - 110 065
Ghaziabad	Plot No. 229/230, Sardar Pashu Ahaar, Bulandshahar Road, Village-chaprola, Ghaziabad
Guwahati	Basundhara Enclave, 1st & 2nd Floor Ulubari, Guwahati - 781007
Hyderabad	201 & 202, Lala-1 Land Mark, 5-4-94 to 97, 2nd Floor, Above Digital Shoppo, Ranigunj, M.G. Road, Secunderabad -500 003
Jaipur	502-506, 5th Floor, Gaurav Towers, Malviya Nagar, Jaipur - 302 017
Kochi	2nd floor, Angels Arcade, South Kalamasserry, Near CUSAT PO Kochi - 682022
Kolkata	Plot-30, Block-GN, Sector-V, Salt Lake city, Kolkata - 700 091
Lucknow	C-3/3 & C-3/4, Sanjay Complex, Near All India Radio, Vidhan Sabha Marg, Lucknow-226001
Mumbai	Appliance Division, Plant 4, Pirojshahnagar, Vikhroli, Mumbai - 400 079
Nagpur	Dr. Bhiwapurkar Chamber, 2nd Floor, Opp. Yashwant Stadium, Dhantoli, Nagpur - 440 012
Patna	Grand Plaza 6th Floor, 6001-6004, Dakbunglow Crossing, Frazer Road, Patna-800001
Pune	Apollo Building Square, Plot No. 60, Survey No. 599, Sahaney Sujan Park, Lullanagar, Bibewadi Road, Pune - 411 040
Raipur	9/1, Besides Bharat Petrol Pump, Opp, Hotel Picadelly, Mahoba Bazaar, G.E. Road, Raipur - 492 001, Chhatisgarh
Ranchi	C/o. Surya Motors, Near Krishi Bazaar Samiti Pandra, Ranchi (Jharkand) - 835 222
Toll-Free :1800-209-5511	
Website: www.godrejappliances.com & www.godrejsmartcare.com E-mail: smartcare@godrej.com	

Protection of Environment:

"Protection of environment" is one of the core values of Godrej and we seek your co-operation to make sure that the product, packaging and plastic material is not disposed as unsorted municipal waste.



This symbol is known as the "Crossed-out Wheellie Bin Symbol". It means that the product should not be disposed of with your general house-hold waste.

It should be disposed of only through the company's collection points with special treatment so as to prevent any damage to the environment. Please call: **1800 209 5511** for applicable buy back arrangement or visit: www.godrejappliances.com/green-think for details about Godrej Appliances authorised collection points.

Godrej | APPLIANCES