

HOW TO GET THE BEST OUT OF YOUR
GODREJ MICROWAVE OVEN...



User Manual

GME 723 CF1 PM/GME 723 CF2 PM/GME 723 CF3 PM

For GME 723 CF3 PM-Black Matrix → Crusty plate to be purchased separately

23 Ltr. Microwave, Convection

Thank you for purchasing Godrej Microwave Oven

Please record the model number and serial number of this unit for future reference. Staple your receipt here for proof of purchase.

Model No: _____

Serial No: _____

Dealer: _____

Dealer Phone No: _____

SPECIFICATION

Power Consumption:	230V~/50Hz, 1300 (Microwave)
	1200W (Grill)
	1200W (Convection)
Rated Microwave Output:	800W
Operation Frequency:	2450MHz
Product Dimensions:	290 x 480 x 405 mm
Oven Capacity:	23 Litres
Cooking Uniformity:	Turntable System
Net Weight:	Approx. 14.0 Kg

TABLE OF CONTENT

IMPORTANT SAFETY INSTRUCTIONS	3
UTENSIL GUIDE	5
INSTALLATION INFORMATION	6
GROUNDING INSTRUCTIONS	6
ELECTRICAL REQUIREMENTS	6
RADIO INTERFERENCE	7
EXTENSION CORD INFORMATION	7
PART NAMES	7
CONTROL PANEL	8
OPERATION INSTRUCTIONS	9
INSTACOOK MENU	15
CLEANING AND CARE	128
TROUBLESHOOTING	129
FAQs	130
WARRANTY	131

IMPORTANT SAFETY INSTRUCTIONS

READ CAREFULLY AND KEEP FOR FUTURE USE

Important Safety instructions

The Safety instructions mentioned below will tell you how to use your Microwave Oven without harming yourself and damaging your oven.

Warning – To reduce the risk of burns, electric shock, fire, injury to persons, or exposure to excessive microwave energy

- Read all the instructions before using your oven
- Do not allow children to use this oven without close supervision

Precautions to avoid possible exposure to excessive microwave energy:

- a) Do not attempt to operate this oven with the door open since open door operation can result in harmful exposure to microwave energy. It is important not to tamper with the safety interlocks.
 - b) Do not place any object between the microwave oven cavity and the door or allow soil or cleaner residue to accumulate on sealing surfaces
 - c) Do not operate the oven if it is damaged. It is particularly important that the oven door closes properly and that there is no damages to the:
 - i. Door (bent)
 - ii. Hinges and latches (broken or loosened)
 - iii. Door seals and sealing surfaces
 - d) It is hazardous for anyone other than properly qualified competent service personnel to repair, adjust or remove the cover which gives protection against exposure to microwave energy
- 1. Do not heat the following items in the microwave oven:** Whole eggs in the shell, water with oil or fat, sealed containers, or closed glass jars.

These items may explode.

- Do not cover or block any openings in the oven
- Use your oven only for the operations described in this manual
- Do not run the oven empty, without food in it

- Do not deep fry in your microwave oven
 - Do not remove the turn table while using the microwave oven
 - Do not make popcorn, peanuts and suji roast in plastic utensil. Use only microwaveable glass utensil.
2. Only use utensils suitable for use in microwave oven
 3. Remove wire twist-ties and metal handles from paper or plastic containers/bags before placing them in the oven
 4. The oven should be cleaned regularly and any food deposits should be removed. Failure to maintain the oven in a clean condition could lead to deterioration of the surface, and could adversely affect the life of the appliance and possibly result in a hazardous situation.
 5. When the appliance is operated in the combination mode, children should only use the oven under adult supervision due to the temperatures generated.
 6. To avoid a fire hazard do not severely overcook food. Severely overcooked foods can start a fire in the oven.
 7. When heating food in plastic or paper containers, keep an eye on the oven due to the possibility of ignition.
 8. If smoke is observed, switch off or unplug the appliance and keep the door closed in order to stifle any flames
 9. Do not use the cavity for storage purposes. Do not leave paper products, cooking utensils, or food in the cavity when not in use.
 10. Do not use this oven for commercial purposes. This appliances is intended to be used in household and similar application such as:
 - Staff Kitchen areas in shops, offices and other working environments;
 - Farm Houses;
 - By clients in hotels, motels and other residential environments;
 - Bed and breakfast type environments.

11. When cleaning the door and the surfaces that touch the door, use only mild, non-abrasive soaps or detergents and a sponge or soft cloth
12. Do not use corrosive chemicals or vapours, in this appliance. This type of oven is specifically designed to heat, cook, or dry food. It is not designed for industrial or laboratory use
13. Do not use or store this appliance outdoors. Do not use this product near water for example near a kitchen sink, in a wet basement, or near a swimming pool, and the likes.
14. Do not tamper with the built-in safety switches on the oven door. The oven has several built-in safety switches to make sure the power is off when the door is open.
15. If the supply cord is damaged, it must be replaced by the manufacturer, its service agent or similarly qualified persons in order to avoid a hazard
16. If your oven is dropped or damaged, have it thoroughly checked by a qualified service technician before using it again
17. The temperature of accessible surfaces may be high when the appliance is operating. Keep cord away from heated surface, and do not cover the oven.
18. Do not immerse the electrical cord or plug in water
19. Pierce food with heavy skin such as potatoes, whole squashes, apples, tomatoes, brinjals, mutton, chicken before cooking
20. Cooking utensils may become hot because of heat transferred from heated food. Potholders may be needed to handle the utensils. Utensils should be checked to ensure that they are suitable for use in microwave ovens.
21. The microwave oven shall not be placed in a cabinet
22. Liquids, such as water, coffee, or tea can be overheated beyond the boiling point without appearing to be boiling. Visible bubbling or boiling when the container is removed from the microwave oven is not always present **THIS COULD RESULT IN VERY HOT LIQUIDS SUDDENLY BOILING OVER WHEN THE CONTAINER IS DISTURBED OR A SPOON OR OTHER UTENSIL IS INSERTED INTO THE LIQUID.**
23. To reduce the risk of injury to persons:
 - Do not overheat the liquid
 - Stir the liquid both before and halfway through heating it
 - While cooking or reheating in microwave mode, ensure the vent of the lid is kept open at all times or the lid is partially open
 - After heating, allow the container to stand in the microwave oven for a short time before removing the container
 - Use extreme care when inserting a spoon or other utensil into the container
24. The contents of feeding bottles and baby food jars shall be stirred or shaken and the temperature checked before consumption, in order to avoid burns
25. The appliances is not intended for use by persons (including children) with reduced physical, sensory or mental capabilities, or lack of experience and knowledge, unless they have been given supervision or instruction concerning use of the appliance by a person responsible for their safety
26. The rear surface of the appliance shall be placed against the wall
27. Microwave oven is intended for heating food and beverages. Drying of food or clothing and heating of warming pads, slippers, sponges, damp cloth and similar may lead to risk of injury, ignition or fire.
28. Microwave heating of beverages can result in delayed eruptive boiling, therefore care must be taken when handling the container.
29. Details for cleaning door seals, cavities and adjacent parts are given on page **CLEANING AND CARE.**
30. No temperature sensing probe to be inserted into the food placed inside the cavity of this oven by user, during switched ON state. A temperature probe may be placed on the food once the food is taken outside the oven.
31. The microwave is intended to be used freestanding.

UTENSIL GUIDE

1. The ideal material for a microwave utensil is transparent to microwave, it allows energy to pass through the container and heat the food
2. Microwave cannot penetrate metal, so metal utensils or dishes with metallic trim should not be used
3. Do not use recycled paper products when microwave cooking, as they may contain small metal fragments which may cause sparks and/or fires
4. Round/oval dishes rather than square/oblong ones are recommend, as food in corners tends to overcook.
5. Narrow strips of aluminum foil may be used to prevent overcooking of exposed areas. But be careful don't use too much and keep a distance of 1 inch (2.54cm) between foil and cavity.

The list below is a general guide to help you select the correct utensils.

Cookware	Microwave	Grill	Convection	Combination*
Heat-Resistant Glass	Yes	Yes	Yes	Yes
Non Heat-Resistant Glass	No	No	No	No
Heat-Resistant Ceramics	Yes	Yes	Yes	Yes
Microwave-Safe Plastic Dish	Yes	No	No	No
Kitchen Paper	Yes	No	No	No
Metal Tray	No	Yes	Yes	No
Metal Rack	No	Yes	Yes	No
Aluminum Foil & Foil Container	No	Yes	Yes	No
Cotton Cloth, Wood	Yes**	No	No	No
Melamine	No	No	No	No

*Combination: applicable for both "microwave+grill", and "microwave+convection" cooking.

**Only for short time reheating.

INSTALLATION INFORMATION

- 1) Select a level surface that provides enough open space for the intake and/or outlet vents

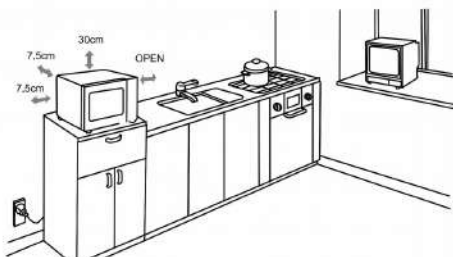

A minimum clearance of 7.5 cm is required between the oven and any adjacent walls. One side must be open.

- a) Leave a minimum clearance of 30 cm above the oven
- b) Do not remove the legs from the bottom of

- a) the oven
 - c) Blocking the intake and/or outlet openings can damage the oven
 - d) Place the oven as far away from radios and TV as possible
- 2) Plug your oven into a standard household outlet. Be sure the voltage and frequency is the same as the voltage and the frequency on the rating label at the back of the microwave oven.
 - 3) Do not operate the oven without glass tray, roller support and shaft in their proper positions (applicable for microwave ovens with turn tables)

WARNING: Do not install oven over a range cooktop or other heat-producing appliance. If installed near or over a heat source, the oven could damage and the warranty would be void.



The accessible surface may be hot during operation.

GROUNDING INSTRUCTIONS

This appliance must be grounded. This oven is equipped with a cord having a grounding wire with a grounding plug. It must be plugged into a wall receptacle that is properly installed and grounded. In the event of an electrical short circuit, grounding reduces risk of electric shock by providing an escape wire for the electric current. It is recommended that a separate circuit serving only the oven be provided. Using a high voltage is dangerous and may result in a fire or other accident causing oven damage.

WARNING Improper use of the grounding plug can result in a risk of electric shock.

Note:

- 1) If you have any questions about the grounding or electrical instructions, consult a qualified electrician or service person
- 2) Neither the manufacturer nor the dealer can accept any liability for damage to the oven or personal injury resulting from failure to observe the electrical connection procedures

The wires in this mains cable are coloured in accordance with the following code:
Green and/or Yellow = EARTH
Blue and/or Black = NEUTRAL
Brown and/or Red = LIVE

ELECTRICAL REQUIREMENTS

The oven is designed to operate on a standard 230V/50Hz household outlet. Be sure the circuit is at least 15A or 20A and the

microwave oven is the only appliance on the circuit.

RADIO INTERFERENCE

Operation of the microwave oven can cause interference to your radio, TV, or similar equipment. When there is interference, it may be reduced or eliminated by taking the following measures:

1. Clean door and sealing surface of the oven
2. Reorient the receiving antenna of radio or television
3. Relocate the microwave oven with respect to the receiver
4. Move the microwave oven away from the receiver
5. Plug the microwave oven into a different outlet so that microwave oven and receiver are on different branch circuits

EXTENSION CORD INFORMATION

1. A short power supply cord is provided to reduce the risks resulting from becoming entangled in or tripping over a longer cord
2. DO NOT USE AN EXTENTION CORD

PART AND ACCESSORIES NAME

Glass tray 1
Turntable ring assembly 1
Instruction manual 1

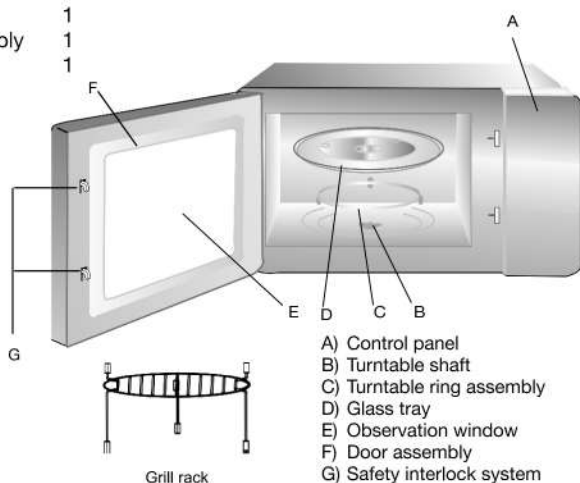

CONTROL PANEL



1. DISPLAY SCREEN

Cooking time, power, indicators and present time are displayed.

2. Oil Free, Bread Basket, Tadka/curries, International, India's Best, Breakfast/Snacks, Desserts/Soups, Paneer/Ghee/Curd, Fermentation/keep warm, Deodoriser/Steam Clean –

- Press to select dishes under the particular option.

3. Weight

- Used to set the weight.

4. Defrost

- Press to defrost.

5. Clock/Kitchen Timer

- To set clock/Kitchen timer.

6. Weight Adj

- Used to adjust the weight.

7. Microwave-

- Press to set microwave cooking program.

7. Grill -

- Press to set Grill cooking program.

8. Convection

- Press to set convection cooking program.

9. Combination

- Press to set combination cooking program.

10. Stop/Clear

- Touch to stop cooking program or clear the same.

11. Start

- Press to start the microwave oven.

OPERATION INSTRUCTION

1. Clock Setting

When the microwave oven is electrified, the oven will display "0:00", buzzer will ring once.

The input time should be within 0:00--23:59(24 Hour).

Example: To set 12:12 .

- (1) Press " **CLOCK/KITCHEN TIMER** " Once "00:00" displays.
- (2) Press the number buttons of "1", "2", "1", "2" in order.
- (3) Press " **CLOCK/KITCHEN TIMER** " to finish clock setting. ":" will flash, and the time will light.

- Note:**
- 1) The clock will not work if it is not set when powered.
 - 2) During the process of clock setting, if you press "**STOP/CLEAR**" or if no operation in 5 minute , the oven will go back to the previous status automatically.

2. Microwave Cooking

Select different microwave power level and set cooking time as you wish. There are five power levels available for choosing. Keep on pressing "**MICROWAVE**" to choose the power.

Example: If you want to use 80% microwave power to cook for 10 minutes, you can operate the oven as the following steps.

- 1) Press "**MICROWAVE**" once, the oven will display "P100".
- 2) Press "**MICROWAVE**" once again to choose 80% power, the oven will display "P80".
- 3) Press the number buttons of "1", "0", "0", "0" in order, the oven will display "10:00".
- 4) Press "**START/+30SEC.**" to start cooking, ":" will light.

Note: "**MICROWAVE**" Pad presses instructions

Presses Instructions	Display	Microwave Power
1	P100	100%
2	P 80	80%
3	P 50	50%
4	P 30	30%
5	P 10	10%

3. Kitchen Timer

- (1) Press " **CLOCK/KITCHEN TIMER** " twice, LED will display 00:00.
- (2) Press the number keys and enter the correct time.(The maximum cooking time is 99 minutes and 99 seconds.)
- (3) Press " **START/+30SEC.** " to confirm setting, clock indicator will be lit.
- (4) When the kitchen time is reached, the buzzer will ring 5 times. Then turn back to waiting state. If the clock has been set (24-hour system), LED will display the current time.

Note: 1) The kitchen Time is different from 24-hour system. Kitchen Timer is a timer.

2) During kitchen timer, any program cannot be set.

4. Grill Cooking

Example: If you want to use 100% to cooking for 35 minutes, you can operate the oven as the following steps.

- 1) Press the "**GRILL**" key , the oven will display " G-1 " .
- 2) Press the number buttons of "3", "5", "0", "0" in order, the oven will display "35:00"
- 3) Press the "**START/+30SEC.**" key to start cooking.

Note: If half the grill time passes, the oven will sound twice to tell you to turn the food over. You can just leave it continue cooking. But in order to have a better effect of grilling food, you should turn the food over, close the door, and then press "START/+30SEC." to continue cooking.

5. Convection Cooking(With preheating function)

The convection cooking can let you to cook the food as a traditional oven. Microwave is not used. It is recommended that you should preheat the oven to the appropriate temperature before placing the food in the oven.

- 1) Press the "**CONVEC.**" key several times, the oven will display "180".
(Press the "**CONVEC.**" key several times to select the temperature.)
- 2) Press the "**START/+30SEC.**" key to start cooking. The temperature figure will flash when reach to the temperature in advance and buzzer will ring twice to remind you to put the food into the oven.
- 3) Press the number buttons of "4", "0", "0", "0" in order, the oven will display "40:00"
- 4) Press the "**START/+30SEC.**" key to start cooking.

Note: a. Cooking time cannot be input until the preheating temperature arrives.

If the temperature arrives, door must be opened to input the cooking time.

b. If the time not input in 5 minutes, the oven will stop preheating. The buzzer sound five times and turn back to waiting states.

6. Convection Cooking(Without preheating function)

- 1) Press the **"CONVEC."** key once, the oven will display "110".
(Press the **"CONVEC."** key several times to select the temperature.)
- 2) Press the number buttons of "4", "0", "0", "0" in order, the oven will display "40:00".
- 3) Press the **"START/+30SEC."** key to start cooking.

Note: "CONVEC." Pad presses instructions

Presses Instructions	Display	Convection
1	110 ⁰ C	●
2	120 ⁰ C	●
3	130 ⁰ C	●
4	140 ⁰ C	●
5	150 ⁰ C	●
6	160 ⁰ C	●
7	170 ⁰ C	●
8	180 ⁰ C	●
9	190 ⁰ C	●
10	200 ⁰ C	●

7. Combination Cooking

Example: If you want to use combination to cook (C-1) for 40 minutes, you can operate the oven as per the following steps.

- 1) Press the **"COMBI."** key once, the oven will display "C-1".
- 2) Press the number buttons of "4", "0", "0", "0" in order, the oven will display "40:00".
- 3) Press the **"START/+30SEC."** key to start cooking.

Note: "COMBI." Pad presses instructions

Presses Instructions	Display	Microwave Power	Grill Power	Convection Power
1	C-1	●		●
2	C-2	●	●	
3	C-3		●	●
4	C-4	●	●	●

8. Defrost By time

1) Press **"DEFROST"** once, the oven will display "d-1".

2) Input the figure of the time of cooking.
(The maximum cooking time is 99 minutes and 99 seconds.)

3) Press **"START/+30SEC."** key to start defrosting.

9. Defrost By weight

1) Press **"DEFROST"** pad twice, the oven will display "d-2".

2) Input the figure of the weight of food.
(The input figure of the weight should be within 100--2000g.)

3) Press **"START/+30SEC."** key to start defrosting.

10. Defrost Groud meat

1) Press **"DEFROST"** pad thrice, the oven will display "d-3".

2) Input the figure of the weight of food.
(The input figure of the weight should be within 100—2000g)

3) Press **"START/+30SEC."** key to start defrosting.

11. Defrost Sea food

1) Press **"DEFROST"** pad 4 times, the oven will display "d-4".

2) Input the figure of the weight of food.
(The input figure of the weight should be within 100—2000g)

3) Press **"START/+30SEC."** key to start defrosting.

12. Multi-Stage Cooking

Two stages of cooking can be maximumly set. If one of the stages is defrosting, it should be put in the first stage, and auto menu should not be set here. The buzzer will ring once after each stage and the next stage will begin.

Example: If you want to cook the food with 100% microwave power for 10 minutes+ 80% microwave power for 15 minutes. Do it as following:

- 1) Press " **MICROWAVE**" once to choose 100% microwave power;
- 2) Press number keys "1","0","0","0" in order to adjust the cooking time;
- 3) Press " **MICROWAVE**" twice to choose 80% microwave power;
- 4) Press number keys "1","5","0","0" in order to adjust the cooking time;
- 5) Press " **START/+30SEC.** " to start cooking.

13. EXPRESS COOKING

When the oven is in the waiting states, press "**START/+30SEC.**" key to start cooking with full microwave power for 30 seconds.(The maximum setting is 99 minutes and 99 seconds.)

When the oven is in the grill, convection and combination cooking states, press "**START/+30SEC.**" key to add 30 seconds cooking time.

14. Lock-out Function for Children

Lock: In waiting state, press "**STOP/CLEAR**" for 3 seconds, there will be a long "beep" denoting entering into the children-lock state and a key "  " will light. The oven will display "0:00" or current time.

Lock quitting: In locked state, press **STOP/CLEAR** for 3 seconds, there will be a long "beep" denoting that the lock is released and "  " will go out.

15. Display Specification

- (1) When cooking finishes, buzzer sounds five times to alert user that the cooking finishes.
- (2) If the oven door is open, the lamp will turn off automatically after ten minutes.
- (3) During setting the program, the oven will turn back to waiting state after five minutes.

16. Inquiring Function

In cooking state, press “COMBI”, “MICROWAVE”, “GRILL” or “CONVEC”, and the current power level will be displayed for 2-3 seconds.

17. Auto Cook

There are 10 buttons available on the panel to select different types of recipes one wishes to cook.

Sr. No.	COOK	Sr. No.	COOK	Sr. No.	COOK	Sr. No.	COOK
1	Oil Free	4	International	7	Desserts/Soups	10	Deodorizer/Steam Clean
2	Bread Basket	5	India's Best	8	Paneer/Ghee/Curd		
3	Tadka/Curries	6	Breakfast/Snacks	9	Fermentation/Keep Warm		

Example: For Cooking RESHMI KABAB of 300g:

- (1) Press "OIL FREE" button, display will show "OF".
- (2) Press "09" on the number pad for selecting "RESHMI KABAB ". Display will show "OF- 09"
- (3) Now press: "Weight" button once for selecting "300 grams". Display will show "300".
- (4) Press "START/QUICK START" to start cooking, Display will show the count down, with the mode of working "convection" being displayed on the bottom right.

INSTACOOK MENU

OIL FREE

Category	Recipe-	Ingredients:	300 gr	500 gr
OF1	CHICKEN LOLLY POPS	Chicken Wings	300 gr	500 gr
		Maida	2 tbsp	3 tbsp
		Eggs	2	3
		Soya Sauce	1 tbsp	1½ tbsp
		Green Chilli Paste	2 tsp	2½ tsp
		Ginger, Garlic Paste	1½ tsp	2 tsp
		Garam Masala	1½ tsp	2 tsp
		Pepper Powder	¼ tsp	½ tsp
		Chilli Sauce	1 tbsp	1½ tbsp
		Red Color (Optional)		
		Salt To Taste		
<p>Method of Preparation: Marinate the chicken with the all ingredients for 1 hour . Arrange the marinate chicken in a lightly greased crusty plate and then place the crusty plate on the mesh rack in the microwave oven. Select category, enter weight and press start. Turn once in-between.</p>				

Category	Recipe-	Ingredients:	300 gr	500 gr
OF2	MUTTON KABAB	Boneless Mutton, Minced	300 gr	500 gr
		Coriander Powder	1 tsp	2 tsp
		Khus Khus Grinded	½ cup	¾ cup
		Cumin Powder	1 tsp	2 tsp
		Curd	½ cup	¾ cup
		Garlic Paste	1 tsp	2 tsp
		Ginger Paste	1 tsp	2 tsp
		Onion Paste	½ cup	¾ cup
		Salt To Taste		
<p>Method of Preparation: “Apply ginger-garlic paste, coriander- cumins powder, khus khus, beaten curds, salt, to the minced mutton and allow the mutton to marinate for about 2 hours. Make the meat into shape of kebab and arrange the mutton kababs in a lightly greased crusty plate and place the crusty plate on the mesh rack in the microwave oven. Select category, enter weight and press start.</p>				

OIL FREE

Category	Recipe-	Ingredients:	300 gr	500 gr
OF3	CHICKEN TANDOORI	Chicken Breast Or Legs	300 gr	500 gr
		Red Chilli Powder	1 tsp	1½ tsp
		Lemon Juice	1 tsp	1½ tsp
		Yogurt	¾ cup	1 cup
		Ginger Paste	1 tsp	1½ tsp
		Garlic Paste	1 tsp	1½ tsp
		Garam Masala Powder	1 tsp	1½ tsp
		Chaat Masala	1 tsp	1½ tsp
		Salt To Taste		

Method of Preparation:

"Marinate the chicken with the all ingredients for 3 hours. Arrange the marinate chicken in a lightly greased crusty plate and place the crusty plate on the mesh rack in the microwave oven. Select category, enter weight and press start. Turn once in-between."

Category	Recipe-	Ingredients:	300 gr	500 gr
OF4	LITTI	Wheat Flour	2 cup	2½ cup
		Yogurt	1 cup	1½ cup
		Salt To Taste		
		Filling		
		Sattu	1½ cup	2 cup
		Ginger, Garlic Paste	1½ tsp	1¾ tsp
		Cloves	5	6
		Green Chilies (Chopped)	¾ tsp	1 tsp
		Coriander Leaves (Chopped)	½ cup	¾ cup
		Onion Seeds	1½ tsp	1¾ tsp
		Salt To Taste		
		Lemon Juice	1½ tsp	1¾ tsp

Method of Preparation:

Add salt and yogurt to the wheat flour and knead into a soft dough. Rest the dough for some time.

For the filling mix sattu with all filling ingredients. Now, Divide the dough into lemon sized balls and spread them into small puris with your fingers. Place a portion of the filling mixture and once again roll them into balls. Arrange them on a lightly greased baking dish and place the baking dish on the mesh rack in the microwave oven. Select category, enter weight and press start. Turn once in-between.

OIL FREE

Category	Recipe-	Ingredients:	300 gr	500 gr
OF5	BATI	Whole Wheat Flour (Gehun Ka Atta)	1½ cup	2½ cup
		Semolina (Rava)	¾ cup	1 cup
		Besan (Bengal Gram Flour)	2½ tbsp	4 tbsp
		Milk	1 cup	2 cup
		Melted Ghee	¾ cup	1 cup
		Salt To Taste		

Method of Preparation:

"Mix all the ingredients and knead into a firm dough and make round flatten shape batis . Arrange batis in a lightly greased crusty plate and place the crusty plate on the mesh rack in he microwave oven. Select category, enter weight and press start. Turn once in-between."

Category	Recipe-	Ingredients:	300 gr	500 gr
OF6	CHICKEN ROAST	Chicken	300 gms	500 gr
		Grounded Black Pepper	1½ tsp	2 tsp
		Lemon Juice	1½ tsp	2 tsp
		Garlic Paste	1½ tsp	2 tsp
		Thyme	1½ tsp	2 tsp
		Salt To Taste		

Method of Preparation:

"Take a mixing bowl. Add oil, chicken, salt, pepper, garlic, lemon, thyme and mix well. Now, set it aside for 30 minutes to marinate. Arrange marinated chicken in a lightly greased crusty plate and place the crusty plate on the mesh rack and in the microwave oven. Select category, enter weight and press start. Turn once in-between."

OIL FREE

Category	Recipe-	Ingredients:	300 gr	500 gr
OF7	CHICKEN KABABS	Boneless Chicken (Cut Into 1½" Pieces)	300 gr	500 gr
		For Marinade		
		Onion Paste	¾ cup	1 cup
		Garlic, Ginger Paste	1½ tsp	2 tsp
		Cumin Powder	¾ tsp	1 tsp
		Red Chilli Flakes	¾ tsp	1 tsp
		black pepper (freshly crushed)	¾ tsp	1 tsp
		Barbeque Sauce	1½ tsp	2 tsp
		Oregano	1½ tsp	2 tsp
		Thyme	1½ tsp	2 tsp
		Salt To Taste		

Method of Preparation:

"Take a mixing bowl. Mix all the ingredients and then add the chicken. Mix well & set it aside for 1 hour. Keep the marinated chicken on lightly greased crusty plate and place the crusty plate on the mesh rack in the microwave oven. Select category, enter weight and press start. Turn once in-between."

Category	Recipe-	Ingredients:	300 gms	500 gr
OF8	RESHMI KABAB	Boneless Chicken	300 gms	500 gr
		Garlic Paste	1½ tsp	2 tsp
		Ginger Paste	1½ tsp	2 tsp
		Coriander Leaves Paste	1½ tbsp	2 tbsp
		Onions Paste	1½ tbsp	2 tbsp
		Yoghurt	1½ cup	2 cup
		Almonds Grated	1½ tbsp	2 tbsp
		Juice Of Lemon	1	1
		Salt To Taste		

Method of Preparation:

"Marinate the chicken with the all ingredients for 2 hour. Arrange the marinate chicken in a lightly greased baking dish and place the baking dish on the mesh rack in the microwave oven. Select category, enter weight and press start. Turn once in-between."

OIL FREE

Category	Recipe-	Ingredients:	300 gms	500 gr
OF9	CHICKEN 65	Chicken Breast - Boneless	300 gms	500 gr
		Red Chilli Powder	1 tsp	1½ tsp
		Pepper Powder	1 tsp	1½ tsp
		Egg Whites	2	3
		Corn Flour	½ tbsp	1 tbsp
		Wheat Flour	½ tbsp	1 tbsp
		Butter Milk	½ cup	1 cup
		Ginger Paste	1 tsp	1½ tsp
		Garlic Paste	½ tsp	1 tsp
		Orange Food Color	½ tsp	1 tsp
		Lemon Juice	1 tsp	1½ tsp
		Salt To Taste		

Method of Preparation:

Marinate the chicken with the all ingredients for 2 hours. Arrange the marinate chicken in a lightly greased crusty plate and place the crusty plate on the mesh rack in the microwave oven. Select category, enter weight and press start. Turn once in-between.

Category	Recipe-	Ingredients:	200 gr	300 gr
OF10	CHICKEN NUGGETS	All-Purpose Flour	½ cup	¾ cup
		Garlic Paste	1 tsp	1½ tsp
		Ground Black Pepper	½ tsp	¾ tsp
		Chicken Breasts, Cut Into 1½-Inch Pieces	200 gr	300 gr
		Breadcrumbs	1 cup	1½ cup
		Egg	1	2
		Salt To Taste		

Method of Preparation:

"Take flour, garlic, pepper, salt and chicken. Mix them well. Dip the chicken in the beaten egg, then in the breadcrumbs. Arrange them on a lightly greased baking dish and place the baking dish on the mesh rack in the microwave oven. Select category, enter weight and press start. Turn once in-between."

OIL FREE

Category	Recipe-	Ingredients:	200 gr	300 gr
OF11	CORN KABAB	Boiled Potatoes	200 gr	300 gr
		Boiled Sweet Corns	½ cup	¾ cup
		Onions (Chopped)	½ cup	¾ cup
		Green Chillies (Chopped)	1 tsp	1½ tsp
		Coriander (Chopped)	2 tbsp	3 tbsp
		Pudina (Chopped)	2 tbsp	3 tbsp
		Melted Butter	2 tbsp	3 tbsp
		Garam Masala	1 tsp	1½ tsp
		Lemon Juice	1 tsp	1½ tsp
		Bread Crumbs	¾ cup	1 cup
		Pepper Powder	½ tsp	¾ tsp
		Salt To Taste		
Method of Preparation:				
Mash the boiled potatoes & corns. Mix them well. Now add onions, green chillies, coriander pudina, garam masala, melted butter, salt & pepper. Add bread crumbs & lemon juice. Make long kababs out of this mixture. Keep the kababs on lightly greased crusty plate. Place the crusty plate on the mesh rack in the microwave oven. Select category, enter weight and press start. Turn once in-between. Serve with chutney or sauce.				

Category	Recipe-	Ingredients:	200 gr	300 gr
OF12	CHEESE CORN BALLS	Boiled Sweet Corn Kernels,	1½ cup	2 cup
		Cheese (Grated)	½ cup	½ cup
		Potatoes, Boiled And Mashed	½ cup	½ cup
		Capsicum,	½ cup	½ cup
		Breadcrumbs	1 cup	1½ cup
		Maida	1 tbsp	1 tbsp
		Corn Flour,	1 tbsp	1 tbsp
		Oregano,	few	few
		Salt To Taste,		
Method of Preparation:				
Blend all ingredients together. Roll them to make corn balls. Arrange corn balls in a crusty plate and place the crusty plate on the mesh rack in the microwave oven. Select category, enter weight and press start. Turn once in-between.				

OIL FREE

Category	Recipe-	Ingredients:	200 gr	300 gr
OF13	GRILLED PRAWNS	Prawns	200 gr	300 gr
		Onion Paste	1 cup	1½ cup
		Ginger & Garlic Paste	1½ tsp	2 tsp
		Red Chilli Powder	1 tsp	1½ tsp
		Pepper Powder	¼ tsp	½ tsp
		Salt To Taste		

Method of Preparation:

Marinate the prawns with the all ingredients for 30 minutes. Arrange the marinate prawns in a lightly greased crusty plate and place the crusty plate on the mesh rack in the microwave oven. Select category, enter weight and press start. Turn once in-between.

Category	Recipe-	Ingredients:	200 gr	300 gr
OF14	FISH ROAST	Pomfret - Washed And Cleaned	200 gr	300 gr
		Garlic Paste	1 tsp	1½ tsp
		Lemon Juice	¾ tsp	1 tsp
		Chilli Powder	1 tsp	1½ tsp
		Turmeric Powder	¼ tsp	¼ tsp
		Pepper Powder	¼ tsp	¼ tsp
		Garam Masala	1 tsp	1½ tsp
		Rice Flour	1½ tbsp	2 tbsp
		Salt To Taste		

Method of Preparation:

Mix all the ingredients to make a paste. Toss the fish into it and apply evenly on all sides. Set aside for 1 hr. Arrange the marinated fish in a lightly greased crusty plate and place the crusty plate on the mesh rack in the microwave oven. Select category, enter weight and press start. Turn once in-between. Remove and serve.

OIL FREE

Category	Recipe-	Ingredients:	200 gr	300 gr
OF15	CHICKEN SAUSAGES	Ready To Cook Chicken Sausages	200 gr	300 gr
Method of Preparation: Arrange chicken sausages in a lightly greased crusty plate, place the crusty plate on the mesh rack in the microwave oven. Select category, enter weight and press start. Turn once in-between.				

Category	Recipe-	Ingredients:	200 gr	300 gr
OF16	FRENCH FRIES	Slice Potatoes Into French Fries	200 gr	300 gr
		Sea Salt As Required		
		Cold Water As Needed		
Method of Preparation: Take water in a mixing bowl, add potatoes into it and set it aside for 1 hr. Drain off the water and dry them with paper towel. Arrange the french fries in a lightly greased crusty plate and place the crusty plate on the mesh rack in the microwave oven. Select category, enter weight and press start. Turn once in-between. Remove and mix with salt. Serve hot.				

Category	Recipe-	Ingredients:	200 gms	300 gms
OF17	FISH CUTLETS	Fish boiled & bones removed	200 gms	300 gms
		Egg	1	2
		Bread slices soaked in water	2	3
		Garlic paste	½ tsp	½ tsp
		Ginger paste	½ tsp	½ tsp
		Bread Crumbs	1 tbsp	1½ tbsp
		Green Chiles	2	3
		Corn Flour	1 tbsp	1½ tbsp
		Garam Masala	1 tbsp	1½ tbsp
		Turmeric Powder	¼ tbsp	½ tsp
		Coriander Leaves	1 tbsp	1½ tbsp
		Salt to taste		
Method of Preparation: Mash the fish and bread slices gently with the hands and adds all ingredients together other than eggs, bread crumbs and mash them lightly. Add all remaining ingredients, mix well and shape them as medium sized cutlets. Arrange cutlets in a lightly greased crusty plate. Place the crusty plate on the mesh rack in the microwave oven. Select category, enter weight and press start. Turn once in-between.				

OIL FREE

Category	Recipe-	Ingredients:	200 gr	300 gr
OF18	VEGETABLE CUTLETS	Potatoes (boiled)	1 cup	1½ cup
		Green Peas (boiled)	¼ cup	½ cup
		Beans (boiled)	¼ cup	½ cup
		Beetroot (boiled)	¼ cup	½ cup
		Corn flour	¼ cup	½ cup
		Dry Mango Powder	1 tsp	1½ tsp
		Red chilli powder	1 tsp	1½ tsp
		Salt to taste		
		Coriander leaves for garnish		
Method of Preparation:				
Blend all boiled ingredients together. Mash them lightly. Add all the remaining ingredients, mix them well and shape them as medium sized cutlets. Arrange cutlets in a lightly greased crusty plate, place the crusty plate on the mesh rack in the microwave oven. Select category, enter weight and press start. Turn once in-between.				

Category	Recipe-	Ingredients:	200 gr	300 gr
OF19	HARA BARA KABAB	Spinach (Finely Chopped)	½ cup	¾ cup
		Green Peas (Boiled And Mashed)	½ cup	¾ cup
		Potatoes (Boiled, Peeled And Grated)	¾ cup	1 cup
		Green Chillies Chopped	1 tsp	1½ tsp
		Ginger Chopped	1 tsp	1½ tsp
		Coriander Leaves Chopped	2 tbsp	2½ tbsp
		Chaat Masala	1 tsp	1½ tsp
		Cornflour	2 tbsp	2½ tbsp
		Salt To Taste		
Method of Preparation:				
In a bowl, take all ingredients other than oil, mix well and make flat shape tikkies of it. Arrange all the tikkies in a lightly greased crusty plate, apply oil and place the crusty plate on the mesh rack in the microwave oven. Select category, enter weight and press start. Serve hot with Sauce.				

OIL FREE

Category	Recipe-	Ingredients:	200 gr	300 gr
OF20	MIX VEG PLATTER	Paneer (Cut 1½" Cubes)	½ cup	¾ cup
		Mushroom Buttons (Trim The Stalk)	½ cup	¾ cup
		Baby Corn (Blanched)	½ cup	¾ cup
		Capsicum (Cut Into Large Cubes)	½ cup	¾ cup
		Tomatoes (Cut Into Quarters)	½ cup	¾ cup
		Onion (Cut Into Quarters & Separated)	½ cup	¾ cup
		For Marinade		
		Curd	2 tbsp	2½ tbsp
		Thick Cream	2 tbsp	2½ tbsp
		Cornflour	2 tbsp	2½ tbsp
		Red Chilli Powder	1 tsp	1½ tsp
		Ginger Garlic Paste	1 tsp	1½ tsp
		Tandoori Masala	1 tsp	1½ tsp
		Tandoori Color	a pinch	a pinch
		Salt To Taste		

Method of Preparation:

"Take a mixing bowl, add all the ingredients of marinade and add the panner, mushroom buttons, baby corn, capsicum, tomatoes, onion. Mix them well & set aside for ½ hour for marinate. Keep the marinated vegetables on lightly greased baking dish, place the baking dish on the mesh rack in the microwave oven. Select category, enter weight and press start. Serve hot."

BREAD BASKET

Category	Recipe-	Ingredients:	1 (230 gms)
BB1	MILK BREAD	All Purpose Flour (Maida)	2 cups
		Dry Yeast	2 tsp
		Sugar	1 tbsp
		Oil	1 tbsp
		Salt	1 tsp
		Milk Powder	3 tbsp
		Water	$\frac{3}{4}$ cup
<p>Method of Preparation: "Take warm water in a bowl, add dry yeast, sugar, mix well and cover with lid, set a side for 5 minutes. Take another mixing bowl, add maida, oil, salt, milk powder and dry yeast water, mix well to make a smooth, soft dough. Punch the dough for 10 minutes. Set it aside for 15 minutes. Punch the dough again for 7 minutes. Set the dough batter in a bread tin and cover with lid, set a side again for 20 minutes. Step 1: To preheat the oven, select category, enter weight & press start. Step 2: When your oven beeps, arrange bread tin in on the turn table and press start. "</p>			

BREAD BASKET

Category	Recipe-	Ingredients:	1 (230 gms)
BB2	GARLIC BREAD	Milk (Warm)	¼ cup
		Dry Yeast	1 tsp
		Sugar	1 tsp
		Salt	a pinch
		Garlic (Finely Chopped)	3 cloves
		Oregano	¾ tsp
		Butter (Unsalted And Melted)	1 tbsp
		Maida	1 cup
		Oil	2 tsp
		For Garlic Butter:	
		Butter, Melted	¾ cup
		Garlic, Finely Chopped	3 cloves
		Coriander Leaves, Finely Chopped	2 tbsp
		Other Ingredients:	
		Maida (To Dust)	3 tbsp
		Grated Cheese	¼ cup
		Chili Flakes	2 tsp
		Oregano	1 tsp
		Mixed Herbs	1 tsp

Method of Preparation:

"Take warm milk in a bowl. Add dry yeast, sugar, mix well and cover with a lid. Set it aside for 5 minutes. Add salt, butter, garlic, oregano and maida. Mix well to make a smooth and soft dough.

Add oil and punch the dough for 5 minutes. Set a side for 15 minutes. Punch again the dough for 5 minutes. Set the dough batter in a bowl and cover with lid. Set it aside again for 1 hour.

Mix batter, garlic, coriander leaves in a bowl and spread it over the dough. Further top it with cheese on half of the dough. Season with chili flakes and oregano and fold the dough. Seal the edges.

Brush and top with the prepared garlic butter, chili flakes and mixed herbs. Make marks over bread without cutting them fully and place it on lightly greased baking dish.

Step 1: For preheat the oven select category & enter weight & press start.

Step 2: When you hear a beep, arrange baking dish in on the turn table and press start. Cut and serve."

BREAD BASKET

Category	Recipe-	Ingredients:	1 (230 gms)
BB3	WHEAT BREAD	Water (Warm)	1¼ cups
		Active Dry Yeast	½ tbsp
		Salt	1 tsp
		Sugar	1 tbsp
		Butter, Melted	2 tbsp
		Curd	2 tbsp
		Whole Wheat Flour	3 cups
		Milk (For Brushing)	2 tbsp
<p>Method of Preparation: "Take warm water in a bowl, add dry yeast, sugar, mix well and cover with lid. Set it aside for 5 minutes. Take another mixing bowl. Add wheat flour, salt, butter, dry yeast and curd. Mix well to make a smooth and soft dough. Punch the dough for 10 minutes. Set a side for 15 minutes. Punch again the dough for 5 minutes. Set the dough batter in a bread tin and cover with lid, set a side again for 20 minutes. Step 1: To preheat the oven, select category, enter weight & press start. Step 2: When your oven beeps, arrange bread tin in on the turn table and press start. "</p>			

Category	Recipe-	Ingredients:	(230 gms)
BB4	TOOTY FROOTY BREAD	All-Purpose Flour	2 cups
		Custard Powder	2 tbsp
		Sugar	2 tsp
		Milk Powder	2 tbsp
		Dry Yeast	1½ tsp
		Tutti Frutti	½ cup
		Oil	2 tbsp
		Water As Required	
		Salt As Required	
<p>Method of Preparation: "Take warm water in a bowl. Add dry yeast, sugar, mix well and cover with a lid. Set it aside for 5 minutes. Take another mixing bowl. Add maida, oil, salt, milk powder, custard powder, butter, dry yeast and water. Mix well to make a smooth and soft dough. Punch the dough for 10 minutes. Set it aside for 15 minutes. Punch the dough again for 7 minutes. Set the dough batter in a bread tin and cover with al lid. Set it aside again for 20 minutes. Step 1: To preheat the oven, select category, enter weight & press start. Step 2: When your oven beeps, arrange bread tin in on the turn table and press start. "</p>			

BREAD BASKET

Category	Recipe-	Ingredients:	1 (230 gms)
BB5	BURGER /PAV	All Purpose Flour (Maida)	3 cups
		Salt	1 tsp
		Bread Improver	1 tsp
		Butter	3 tbsp
		Dry Yeast	1 tsp
		Sugar	2 tsp
		Vanilla Powd Er	1 tsp
		Water As Required	

Method of Preparation:

"Take half a cup of warm water,add sugar,yeast and a pinch of flour, stir and cover. Keep aside for 5 minutes. Sieve the flour, add salt and mix,add the yeast water. make soft dough using of water as required. add butter and knead the dough for 10 minutes. cover the dough and leave in a warm place for 30 minutes, till the dough is almost double in size. Knead the dough and make medium smooth roundels from it. Place them on a lightly greased baking tray. Keep distance in between to let them rise and leave it for 20 minutes.

Step 1: To preheat the oven, select category, enter weight & press start.

Step 2: When your oven beeps, arrange baking tray on the turn table and press start. "

Category	Recipe-	Ingredients:	1 (230 gms)
BB6	DABELI KA PAV	All Purpose Flour	3 cup
		Butter	2½ tbsp
		Baking Powder	1 tsp
		Oil	2 tbsp
		Salt	1 tsp
		Butter For Basting (Optional)	
		Sesame Seeds (Optional)	
		Water Or Milk As Required	

YEAST PREPARATION

	Dry Yeast	2 tsp
	Water	1/2 cup
	Milk	3 tsp
	Sugar	2 tsp

Method of Preparation:

"Take half a cup of warm water. Add sugar,yeast and milk. Stir and cover. Keep aside for 5 minutes. Sieve the flour. Add all other ingredients, mix well, add the yeast water. Make soft dough using water or milk as required. Set it aside for 15 minutes. Knead the dough and make medium smooth roundels from it. Place them on a lightly greased baking tray. Keep distance between them to rise and leave it for 20 minutes.

Step 1: For preheat the oven select category, enter weight & press start.

Step 2: When you hear a beep, arrange the baking tray on the low grill mesh rack and press start. "

BREAD BASKET

Category	Recipe-	Ingredients:	1 (230 gms)
BB7	FOCACCIA BREAD	All-Purpose Flour	2½ cups
		Salt	1 tsp
		Sugar	1 tsp
		Active Dry Yeast	1 tbsp
		Garlic Powder	1 tsp
		Dried Oregano	1 tsp
		Dried Thyme	1 tsp
		Dried Basil	½ tsp
		Ground Black Pepper	a pinch
		Oil	2 tbsp
		Mozzarella Cheese	1 cup
		Olive Oil	2 tbsp
		Water (As Required)	
<p>Method of Preparation: "In a large bowl, mix all ingredients other than cheese and olive oil to make a smooth, soft dough. Place the dough in the bowl, cover with a damp cloth and let it rise in a warm place for 30 minutes. Punch dough down and place it on greased baking tray. Pat into a 1/2 inch thick rectangle. Brush the top with olive oil. Sprinkle mozzarella cheese. Step 1: To preheat the oven, select category, enter weight & press start. Step 2: When your oven beeps, arrange baking tray on low grill mesh rack and press start. Serve warm."</p>			

Category	Recipe-	Ingredients:	1 (230 gms)
BB8	SANDWICH BREAD	All-Purpose Flour	2 cups
		Warm Water	½ cup
		Active-Dry Yeast	2 tsp
		Unsalted Butter	1 tbsp
		Milk Powder	3 tbsp
		Sugar	1tsp
		Oil	2 tbsp
		Salt To Taste	
		Water As Required	
<p>Method of Preparation: "Take warm water in a bowl, add dry yeast, sugar and 2 tsp flour. Mix well and set it aside for 5 minutes. Take another mixing bowl, add maida, oil, salt, milk powder, butter, dry yeast and water. Mix well to make a smooth, soft dough. Punch the dough for 10 minutes. Set a side for 15 minutes. Punch the dough again for 5 minutes. Set the dough batter in a bread tin and cover it with a lid. Set it aside again for 20 minutes. Step 1: To preheat the oven, select category, enter weight & press start. Step 2: When your oven beeps, arrange the bread tin on the turn table and press start. "</p>			

BREAD BASKET

Category	Recipe-	Ingredients:	1 (230 gms)
BB9	PIZZA DOUGH	All Purpose Flour (Maida)	2 cups
		Salt	1 tsp
		Dry Yeast	2 tsp
		Sugar	1 tsp
		Oil	3 tsp
		Oregano	1 tsp
		Chili Flakes	1 tsp
		Water As Required	

Method of Preparation:

"Take half a cup of warm water. Add sugar, yeast and a pinch of flour. Stir and cover it. Keep it aside for 5 minutes. Sieve the flour, add salt, chili flakes, oregano, oil and mix well. Add the yeast water and make smooth and soft dough using water as required. Set it aside for 15 minutes. Roll out the dough. Place it on baking tray and prick with a fork. Cover and leave it for 20 minutes to double its size.

Step 1: To preheat the oven select category, enter weight & press start.

Step 2: When your oven beeps, arrange the baking tray on the low grill mesh rack and press start. "

Category	Recipe-	Ingredients:	1 (230 gms)
BB10	BREAD TOAST	bread slices	4 peices

Method of Preparation:

"Arrange bread slices on the high grill mesh rack. Place the grill mesh rack in the oven.

Step 1: Select category, enter weight & press start.

Step 2: When the oven beeps, turn the slices upside down and press start. "

BREAD BASKET

Category	Recipe-	Ingredients:	1 (230 gms)
BB11	ROASTED SANDWICH	Bread slices	8
		Onion (cut into round slices)	1 medium
		Cucumber (cut into round slices)	1 medium
		Tomatoes (cut into round slices)	2 medium
		Green capsicum (cut into round slices)	1 medium
		Green mint and coriander chutney	4 tbsp
		cheese	
		tomato ketchup	4 tbsp
		chaat masala	1 tsp
		salt to taste	

Method of Preparation:

"Arrange paneer, onion, cucumber, tomato, capsicum slices on four bread slices. Sprinkle salt and chaat masala over them. Top it with a cheese slice. Apply one tablespoon green chutney on each of the remaining four slices. Top it with one tablespoon of tomato ketchup. Keep them on lightly greased crusty plate, place the crusty plate on the mesh rack in the microwave oven.

Step 1: Select category, choose weight & press start.

Step 2: When the oven beeps, turn over & press start. Serve hot."

Category	Recipe-	Ingredients:	1 (230 gms)
BB12	TANDOORI ROTI	wheat flour	1 cup
		dry yeast	1 tsp
		sugar	1 tsp
		curd	½ cup
		oil (to finish up the dough)	1 tbsp
		ghee (to brush all the rotis)	4 tbsp
		water (as required)	
		salt to taste	
		wheat flour (for rolling)	

Method of Preparation:

"Take warm water in a bowl. Add dry yeast, sugar. Mix well and cover it with a lid. Set it aside for 10 minutes. Take another mixing bowl, combine all the ingredients other than ghee, including the yeast mixture and knead it into a smooth, soft dough using enough water. Cover it with a damp cloth and keep it aside for 30 minutes. Divide the dough into 6 equal portions. Roll out each portion into a diameter of 5 inches. Use little dry flour for rolling the roti.

Step 1: Keep the tawa on the low rack. Keep it inside the microwave. Select category, enter weight & press start.

Step 2: When the oven beeps, keep 2 rolled out roties on tawa & press start.

Step 3: When the oven beeps again, turn & again press start. Make all the roties following the same procedure. Brush the ghee to the rotis and Serve hot."

BREAD BASKET

Category	Recipe-	Ingredients:	1 (230 gms)
BB13	BUTTER NAAN	All Purpose Flour	1 cup
		Wheat Flour	¼ cup
		Sugar	1 tsp
		Instant Yeast	½ tsp
		Water As Required	
		Curd	2 tbsp
		Butter, Melted	1 tbsp
		Salt As Required	
		Butter For Spreading On The Naan	3 tbsp

Method of Preparation:

"Take warm water in a bowl. Add dry yeast, sugar, mix well and cover with lid. Set it aside for 5 minutes. Take another mixing bowl. Combine all the ingredients, including the yeast mixture and knead into a smooth, soft dough using enough water. Cover it with a damp cloth and keep it aside for 2 hours. Divide the dough into 6 equal portions. Roll out each portion into a diameter of 5 inches. Use little dry flour while rolling the roti.

Step 1: Keep the tawa on the low rack. Keep it inside the microwave oven. Select the category, enter weight & press start.

Step 2: When the oven beeps, keep 2 rolled out naan roti on tawa & press start.

Step 3: When the oven beeps, turn & again press start.

Make all the naan roties following the same procedure. Brush the butter to the naan rotis and Serve hot."

Category	Recipe-	Ingredients:	1(230 gms)
BB14	PLAIN PARATHA	Wheat Flour	1 cup
		Melted Butter	2 tbsp
		Butter Milk	¼ cup
		Ghee As Needed	
		Salt To Taste	
		Water As Required	

Method of Preparation:

"In a bowl combine wheat flour, salt, ghee. Rub them well. Gradually add milk & butter then water & knead a soft dough.

Step 1: Keep tawa on the rack, keep inside the microwave to preheat the tawa. Select category, enter weight & press start. Divide the dough into 5 equal portion (approx of 45-46 gms). Roll out each portion to a diameter of 6" spread ½ tsp ghee/oil all over & dust some dry flour. Fold to half & again repeat the same procedure. So that you get a long strip. Apply few drops of ghee on the strip. Again roll the strip to form a ball. Roll out the ball to 5" diameter for parantha. When the oven beeps, remove the tawa keep 2 rolled out parantha on tawa & press start.

Step 2: When the oven beeps, turn the paranthas & again press start. Make all laccha paranthas following the same procedure. Apply some ghee on top (optional) & crush the parantha slightly to open up the layers. Serve hot with gravy/curry of your choice. Wrap in foil & store. "

BREAD BASKET

Category	Recipe	Ingredients:	1(230 gms)
BB15	ALOO PARATHA	For The Potato Stuffing:	
		Boiled & Mashed Potato	1 cup
		Green Chili, Chopped	2
		Coriander Leaves	2 tsp
		Ajwain	½ tsp
		Garam Masala	¼ tsp
		Chili Powder	¼ tsp
		Salt As Required	
		For The Dough:	
		Wheat Flour	2 cup
		Salt To Taste	
		Oil (Optional)	½ tsp
		Water As Required	
		For Frying The Parathas:	
		Oil Or Ghee As Required	
<p>Method of Preparation: "Mix the flour with salt and oil. Add water and knead a smooth and soft dough. Cover and let the dough rest for 15-20 minutes. Mix all stuffing ingredients uniformly. Take two medium balls from the dough and roll the balls into small circles. Place a few tbsps of the filling on one of the dough circle. Lightly sprinkle some wheat flour and roll the aloo paratha gently into a diameter of 6-8 inches. Step 1: Keep the tawa on low rack. Keep inside the microwave Select category, enter weight & press start. Step 2: When the oven beeps, keep 2 rolled out paratha on tawa & press start. Step 3: When the oven beeps, turn & again press start. Make all the paratha following the same procedure. Brush the oil or ghee to the paratha and Serve hot."</p>			

BREAD BASKET

Category	Recipe-	Ingredients:	1(230 gms)
BB16	KULCHA	Maida	1 cup
		Dry Yeast	1 tsp
		Sugar	1 tbsp
		Warm Water	50 ml
		Fresh Cream	2 tbsp
		Coriander Leaves	as required
		Kalonji	as required
		Oil	½ tsp
		Salt	a pinch

Method of Preparation:

"In a cup take warm water add dry yeast & add sugar. Stir well to dissolve. Keep aside for at least 5 minutes. In a mixing bowl take maida, salt & fresh cream. Mix well with hands. Add the yeast water & knead a firm dough. Pour ½ tsp oil & cover the dough and keep a side for 2 hours. Divide the dough into 4 equal portions (approx. 60 gm each). Make balls & apply butter on top & sprinkle kalonji & coriander leaves on top. Press with fingers & dust with maida & roll out each ball into a diameter of 5". Keep the rolled dough on dusted multi cook tawa. Keep them covered in dark & warm place for at least 30 minutes.

Step1: Select category, enter weight & press start.

Step 2: When the oven beeps, keep tawa with rolled doughs & press start.

Step 3: Apply butter on top of kulchas or roast them a little & serve hot with chhole."

BREAD BASKET

Category	Recipe-	Ingredients:	1(230 gms)
BB17	ALOO KULCHA	For The Potato Stuffing:	
		Boiled & Mashed Potato	1 cup
		Green Chili, Chopped	2
		Coriander Leaves	2 tsp
		Ajwain	½ tsp
		Garam Masala	¼ tsp
		Chili Powder	¼ tsp
		Salt As Required	
		For Kulcha:	
		Maida	1 cup
		Dry Yeast	1 tsp
		Sugar	1 tbsp
		Warm Water	50 ml
		Fresh Cream	2 tbsp
		Coriander Leaves	as required
		Kalonji	as required
		Oil	½ tsp
		salt	a pinch

Method of Preparation:

"In a cup take warm water add dry yeast & add sugar. Stir well to dissolve. Keep aside for at least 5 minutes. In a mixing bowl take maida, salt & fresh cream. Mix well with hands. Add the yeast water, oil & knead a firm dough. Cover the dough and keep a side for 2 hours. Mix all stuffing ingredients, mix uniformly. Take two medium balls from the dough and roll the balls into small circles, apply butter on top & sprinkle kalonji & coriander leaves on top. Place a few tbsps of the filling on one of the dough circle. Press with fingers & dust with maida & roll out each ball into a diameter of 5". Keep the rolled dough on dusted multi cook tawa. Keep them covered in dark & warm place for at least 30 minutes.

Step1: Select category, enter weight & press start.

Step 2: When the oven beeps, keep tawa with rolled doughs & press start.

Step 3: Apply butter on top of kulchas or roast them a little & serve hot."

BREAD BASKET

Category	Recipe-	Ingredients:	1(230 gms)
BB18	GARLIC NAAN	Maida	230 gms
		Curd	4 tbsp
		Milk	100 ml
		Butter	1 tbsp
		Salt	1/8 tsp
		Castor Sugar	1 tsp
		Baking Powder	½ tsp
		Butter (Melted)	1 tsp
		Soda	¼ tsp
		Onion Seeds	1 tsp
		Garlic Paste	1 tsp

Method of Preparation:

"In a bowl sieve the flour, salt, sugar & baking powder. Rub in butter, garlic, curd & soda, add to the dough. Mix it well & knead a soft dough, add the milk & water (if required). After making the dough add melted butter & knead the dough again. Keep the dough covered in a warm place for about 2 hours to ferment properly.

Step 1: Keep the tawa on low rack & keep inside the microwave. Select category, enter weight & press start.

Divide the dough into 10 equal portions/balls. (approx. of 40 gm each). Roll out each portion in an oblong shape. Brush with melted butter & sprinkle onion seeds on the top.

Step 2: When the oven beeps, keep 2 rolled out naan on the tawa & press start.

Step 3: When the oven beeps, turn and press start. Serve hot with gravy curry for your choice. "

Category	Recipe-	Ingredients:	1(230 gms)
BB19	LACHHA PARATHA	Whole Wheat Flour	2 cups
		Ghee	2 Tbsp
		Milk	½ cup
		Water	½ cup
		Salt	½ tsp

Method of Preparation:

"In a bowl combine wheat flour, salt, ghee. Rub them well. Gradually add milk & then water & knead a soft dough. Set aside for 20 minutes.

Step 1: Keep tawa on low rack. Keep it inside the microwave. Select category, enter weight & press start. Divide the dough into equal portion. Roll out each portion to a diameter of 6"". Spread ghee/oil all over & dust some dry flour. Fold to half & again repeat the same procedure. So that you get a long strip. Apply few drops of ghee on the strip. Again roll the strip to form a ball. Roll out the ball to 5"" diameter for laccha parantha.

Step 2: When the oven beeps, keep 2 rolled out laccha parantha on tawa & press start.

Step 3: When the oven beeps, turn the paranthas & again press start. Make all laccha paranthas following the same procedure. Apply some ghee on top. Serve hot with gravy/curry of your choice. "

BREAD BASKET

Category	Recipe-	Ingredients:	1(230 gms)
BB20	TANDOORI NAAN	Maida	230 gr
		Curd	4 tbsp
		Milk For Brushing	100 ml
		Butter	1 tbsp
		Salt	1/8 tsp
		Sugar	1 tsp
		Baking Powder	½ tsp
		Butter (Melted)	1 tsp
		Soda	¼ tsp
		Onion Seeds	1 tsp
		Kalonji Seeds	1 tsp
		Aniseeds	1 tsp

Method of Preparation:

"In a bowl sieve the flour, salt, sugar & baking powder. Rub in butter, curd & soda, add to the dough. Mix it well & knead a soft dough adding all the seeds, milk & water (if required). After making the dough add melted butter & knead the dough again. Keep the dough covered in a warm place for about 2 hours to ferment properly.

Step 1: Keep the tawa on the low rack & keep inside the microwave. Select category, enter weight & press start. Divide the dough into 10 equal portions/balls. (approx. of 40 gm each). Roll out each portion in an oblong shape. Brush with melted butter & sprinkle onion seeds on the top.

Step 2: When the oven beeps, keep 2 rolled out naan on the tawa & press start.

Step 3: When the oven beeps, turn and press start. Serve hot with gravy curry for your choice."

TADKA / CURRY

Category	Recipe-	Ingredients:	100 gr	200 gr
TC1	TADKA / CHOWK/ VAGHAR	Oil / Ghee	2 tbsp	3 tbsp
		Green Chillies	2	3
		Chopped Onions	1	2
		Jeera	½ tsp	1 tsp
		Garlic	½ tsp	½ tsp
		Ginger	½ tsp	½ tsp
		Hing	a pinch	½ tsp
		Mustard Seeds	¼ tsp	½ tsp
		Turmeric Powder	¼ tsp	½ tsp
		Red Chili Powder	1 tsp	1½ tsp
		Curry Leaves	few	few
		Cinnamon	2	3
		Cardamom	2	4
		Bay Leaves	2	3
		Coriander	few	few
		Cloves	3	3
		pepper corns	4	6

Method of Preparation:

Take a microwave oven safe bowl, add the ingredients according to the recipe, mix well. Select Category, enter weight and press start. When the oven beeps, remove and use it for seasoning your dish.

TADKA / CURRY

Category	Recipe-	Ingredients:		
TC2	COCONUT PRAWNS	To Marinate		
		Prawns	200gr	250gr
		Ginger, Garlic Paste	1 tsp	1 tsp
		Red Chili Powder	1 tsp	1 tsp
		Lemon Juice	1 tsp	1 tsp
		Salt To Taste		
		For Curry		
		Granted Coconut	$\frac{3}{4}$ cup	1 cup
		Onion Paste	$\frac{3}{4}$ cup	1 cup
		Tomatoes Paste	$\frac{1}{2}$ cup	$\frac{1}{2}$ cup
		Curry Leaves	5	6
		Green Chilies Chopped	2	2
		Ginger, Garlic Paste	1 tsp	1 tsp
		Red Chili Powder	$\frac{1}{2}$ tsp	$\frac{1}{2}$ tsp
		Coriander Powder	$\frac{1}{2}$ tsp	$\frac{1}{2}$ tsp
		Turmeric Powder	$\frac{1}{4}$ tsp	$\frac{1}{4}$ tsp
		Cumin Powder	$\frac{1}{2}$ tsp	$\frac{1}{2}$ tsp
		Garam Masala	$\frac{1}{2}$ tsp	$\frac{1}{2}$ tsp
		Chopped Coriander Leaves	2 tbsp	2 tbsp
		Oil As Required		
<p>Method of Preparation: "In a mixing bowl, add all marinate ingredients, mix well and set aside 20 minutes for marination. Take another microwave oven safe bowl, combine all the curry ingredients, mix well, keep bowl on the turn table. Step1: Select category, enter weight, press start. Step 2: When the oven beeps, remove and add marinated prawns, mix smoothly and press start. Serve hot."</p>				

TADKA / CURRY

Category	Recipe-	Ingredients:		
TC3	SCHEZWAN CHICKEN	Boneless Chicken	200 gr	250 gr
		Spring Onions	½ cup	¾ cup
		Tomato Ketchup	2 tbsp	2 tbsp
		Dry Red Chillies	2 nos.	2 nos.
		Garlic Paste	½ tsp	1 tsp
		Red Chilli Sauce	1 tsp	1 tsp
		Ajinomoto	1 tbsp	1 tbsp
		Vinegar	¼ tsp	¼ tsp
		Sugar	½ tsp	1 tsp
		Cornflour (Mixed With ¼ Cup Water)	2 tsp	2 tsp
		Oil	2 tbsp	2 tbsp
		Salt To Taste		
Method of Preparation:				
"Step 1: Take a microwave oven safe bowl, add all ingredients other than chicken,ketchup, vinegar, cornflour, mix well and select category & press start.				
Step 2: When the oven beeps, remove and add all remaining ingredients, mix well and & press start. Serve hot."				

Category	Recipe-	Ingredients:	200 g	250 g
TC4	KASHMIRI KAJU PANEER	Paneer Pieces	200 g	250 g
		Kaju Paste	3 tsp	4 tsp
		Onions Chopped	½ cup	¾ cup
		Chopped Ginger	½ tsp	1 tsp
		Chopped Garlic	½ tsp	1 tsp
		Chilli Powder	1 tsp	1 tsp
		Khus Khus Paste	3 tbsp	3 tbsp
		Tomato Puree	½ cup	1 cup
		Milk	½ cup	1 cup
		Garam Masala	½ tsp	1 tsp
		Salt To Taste		
Method of Preparation:				
"Step 1: Take a microwave oven safe bowl, add all ingredients other than paneer, kaju paste, khus khus paste, tomato puree, mix well and select category & press start.				
Step 2: When the oven beeps, remove and add all remaining ingredients, mix well and & press start. Serve hot. "				

TADKA / CURRY

Category	Recipe-	Ingredients:	200 g	250 g
TC5	KADHI	Yogurt	1½ cup	2 cup
		Besan	3 tsp	4 tsp
		Grated Ginger	½ tsp	½ tsp
		Turmeric Powder	¼ tsp	¼ tsp
		Ghee	½ tbsp	½ tbsp
		Dry Red Chillies	2	2
		Curry Leaves	few	few
		Chopped Green Chillies	1	1
		Hing	a pinch	a pinch
		Sugar	½ tsp	1 tsp
		Cumin Seeds	½ tsp	½ tsp
		Mustard Seeds	½ tsp	½ tsp
		Salt To Test		
		Chopped Coriander Leaves For Garnish		
		Water As Required		

Method of Preparation:

"Step 1: Beat the yogurt, water & besan in a vessel so that no lumps are formed. Take a microwave oven safe bowl, add all the ingredients other than yogurt, besan, water mixture, mix well and select Category, enter weight, press start.

Step 2: After the beep, Remove and add the remaining ingredients and mix well and press start. Remove and garnish with coriander leaves and serve."

TADKA / CURRY

Category	Recipe-	Ingredients:	200 gms	250 gms
TC6	MUSHROOM MASALA	Mushrooms (Sliced)	200 gms	250 gms
		Bread Crumbs	¾ tbsp	1 tbsp
		Sour Cream	¾ cup	1 cup
		Flour	¾ tbsp	1 tbsp
		Red Chili Powder	1 tsp	1 tsp
		Lemon Juice	½ tsp	½ tsp
		Butter	1½ tsp	1½ tsp
		Salt To Taste		
		Cheese (Grated) For Garnish		
<p>Method of Preparation: "Step 1: Take a microwave oven safe bowl, add all the ingredients other than bread crumbs, sour cream, flour and cheese and mix them well and select Category, enter weight, press start. Step 2: When the oven beeps, remove and add the remaining ingredients other than the cheese, mix well and press start. Remove, garnish with grated cheese and serve."</p>				

Category	Recipe-	Ingredients:	200 gms	250 gms
TC7	DRUMSTICK LEAVES CURRY	Drum Stick Leaves	2 cup	3 cup
		Coconut Grated	¾ tbsp	1 tbsp
		Masoor Dal	1 tsp	1 tsp
		Cumins Seeds	½ tsp	½ tsp
		Mustard Seeds	½ tsp	½ tsp
		Red Chilli Powder	1 tsp	1½ tsp
		Turmeric Powder	¼ tsp	¼ tsp
		Oil As Required		
		Salt To Taste,		
<p>Method of Preparation: "Step 1: Take a microwave oven safe bowl, add all ingredients other than drum stick leaves, mix well and select category, enter weight, press start. Step 2: After the beep, remove and add remaining ingredients , mix well and press start.Serve hot."</p>				

TADKA / CURRY

Category	Recipe-	Ingredients:		
TC8	HONEY CHILLI POTATO	Potatoes, Sliced	1½ cup	2 cup
		Onion, Finely Chopped	¾ cup	1 cup
		Spring Onions, Chopped Round	¼ cup	¼ cup
		Tomatoes, Chopped	½ cup	½ cup
		Garlic & Ginger Paste	1 tsp	1 tsp
		Soya Sauce	1 tsp	1 tsp
		Tomato Ketchup	1 tbsp	1 tbsp
		Chili Sauce	1 tsp	1 tsp
		Honey	1 tbsp	1 tbsp
		Maida	1 tbsp	1 tbsp
		Corn Flour	1 tbsp	1 tbsp
		Parsley	1 tbsp	1 tbsp
		Oregano	¼ tsp	¼ tsp
		Red Chilli Powder	1 tsp	1 tsp
		Salt To Taste		
		Oil As Required		

Method of Preparation:

"Step 1: Take a microwave oven safe bowl, add oil, sliced potatoes, maida, corn flour, mix well and select category, enter weight and press start. Step 2: After the beep, remove and add some more oil and all remaining ingredients, mix well and press start. Serve hot."

Category	Recipe-	Ingredients:		
TC9	PANEER PEAS CURRY	Paneer Cubes	200 gms	250 gms
		Green Peas	½ cup	½ cup
		Onions	2	2
		Tomato Puree	1 cup	1½ cup
		Ginger, Garlic Paste	1 tsp	1½ tsp
		Coriander Powder	½ tsp	½ tsp
		Cumin Powder	½ tsp	½ tsp
		Garam Masala	½ tsp	½ tsp
		Turmeric Powder	¼ tsp	¼ tsp
		Green Chillies Chopped	2	3
		Heavy Cream	¼ cup	¼ cup
		Oil As Required		
		Salt To Taste		
		Coriander Leaves For Garnish		

Method of Preparation:

Step 1: Take a microwave oven safe bowl, add all the ingredients other than paneer, tomato puree, heavy cream, coriander leaves and salt, mix well and select category, enter weight, press start. Step 2: When the oven beeps, remove and add the remaining ingredients other than the coriander leave and mix well and press start. Remove, garnish with coriander leaves and serve.

TADKA / CURRY

Category	Recipe-	Ingredients:		
TC10	GRATED RADISH CURRY	Radish (Grated)	200 gms	250 gms
		Coconut (Grated)	¾ cup	1 cup
		Onion Chopped	¾ cup	1 cup
		Chilli Powder	1 tsp	1½ tsp
		Chopped Green Chillies	2	3
		Turmeric Powder	¼ tsp	¼ tsp
		Mustard Seeds	½ tsp	½ tsp
		Curry Leaves	few	few
		Oil As Required		
		Salt To Taste		
		Coriander Leaves For Garnish		
<p>Method of Preparation: "Step 1: Take a microwave oven safe bowl, add all the ingredients other than grated radish, grated coconut and coriander leaves, mix well and select Category, enter weight, press start. Step 2: When the oven beeps, remove; add all remaining ingredients other than coriander leaves and mix well, Cover the bowl with lid and press start. Remove, garnish with coriander leaves and serve."</p>				

Category	Recipe-	Ingredients:		
TC11	MUSHROOM CHILLI FRY	Mushrooms Cut Into Halves	200 gms	250 gms
		Mustard Seeds	½ tsp	½ tsp
		Red Chillies	2	2
		Butter To Taste		
		Salt To Taste		
<p>Method of Preparation: "Step 1: Take a microwave oven safe bowl, add all the ingredients other than salt, mix well and select category, enter weight, press start. Step 2: When the oven beeps, remove and add the remaining ingredients, mix well and press start."</p>				

TADKA / CURRY

Category	Recipe-	Ingredients:		
TC12	PALAK MAKAI SHORBA	Spinach	1½ cup	2 cup
		Vegetable Stock Cube	1	1½
		Corn Kernels	½ cup	¾ cup
		Onion Chopped Finely	½ cup	¾ cup
		Cumin Seeds	½ cup	¾ tsp
		Butter	2 tbsp	2½ tbsp
		Milk	½ cup	¾ cup
		Salt To Taste		
		Water If Required		
Method of Preparation:				
Step 1: Take a microwave oven safe bowl, Add butter, cumins, spinach, corn kennels, onions, mix well and select category, eneter weight, press start. After the beep, remove and grind to a fine paste. Step 2: Take another MWO safe bowl, add all other ingredients to grinded paste, mix well and press start. Serve hot.				

Category	Recipe-	Ingredients:		
TC13	CARROT CURRY	Carrots Chopped	200 gms	250 gms
		Roasted Sesame Seeds Paste	½ cup	¾ cup
		Dried Red Chillies	2	2
		Red Chilli Powder	1 tsp	1½ tsp
		Turmeric Powder	¼ tsp	¼ tsp
		Mustard Seeds	½ tsp	½ tsp
		Cumin Seeds	½ tsp	½ tsp
		Urad Dal	1 tsp	1½ tsp
		Curry Leaves	few	few
		Oil As Required		
		Salt To Taste		
		Coriander For Garnish		
Method of Preparation:				
"Step 1: Take a microwave oven safe bowl, add all the ingredients other than carrots and salt. Select category, enter weight, press start. Step 2: After the beep, remove and add the remaining ingredients, mix well and press start. Remove, garnish with coriander and serve."				

TADKA / CURRY

Category	Recipe-	Ingredients:	200 gr	250 gr
TC14	SEV BHAJI	Sev	1½ cup	2 cup
		Tomato Puree	½ cup	¾ cup
		Chopped Tomato	1	1
		Chopped Onions	1	1
		Mustard Seeds	¼ tsp	¼ tsp
		Cumin Seeds	¼ tsp	¼ tsp
		Green Chilli	1	1
		Hing	a pinch	a pinch
		Curry Leaves	few	few
		Turmeric Powder	¼ tsp	¼ tsp
		Red Chilli Powder	1tsp	1tsp
		Ground Coriander	½ tsp	½ tsp
		Ground Cumin	½ tsp	½ tsp
		Oil	½ tbsp	1 tbsp
		Salt To Taste		
		Water As Required		
		Coriander Leaves For Garnish		
<p>Method of Preparation: "Step 1: Take a microwave oven safe bowl, add all the ingredients other than tomato puree, sev, water. mix well, select category, enter weight, press start Step 2: When it beep, remove and add the remaining ingredients, mix well and press start. Remove and garnish with coriander leaves and serve."</p>				

TADKA / CURRY

Category	Recipe-	Ingredients:	200 gr	250 gr
TC15	CRISPY DRUMSTICKS	Scraped Drumstick (Chopped Lenthwise)	200 gr	250 gr
		Mustard Seeds	½ tsp	½ tsp
		Asafoetida	1 pinch	1 pinch
		Chopped Green Chilli	½ tsp	½ tsp
		Chopped Tomato	½ cup	½ cup
		Powdered Turmeric	¼ tsp	¼ tsp
		Cumin Powder	1 tsp	1 tsp
		Curry Leaves	1 pinch	few
		Chopped Garlic	½ tsp	½ tsp
		Chopped Onion	¾ cup	1 cup
		Red Chilli Powder	1 tsp	1 tsp
		Coriander Powder	1 tsp	1½ tsp
		Garam Masala Powder	1 tsp	1 tsp
		Oil As Required		
		Salt To Taste		

Method of Preparation:

"Step 1: Take a microwave oven safe bowl, add all the ingredients other than tomato, drumsticks, mix well, select category, enter weight, press start.

Step 2: When you hear a beep, Remove and add the remaining ingredients, mix well and press start. Serve hot."

Category	Recipe-	Ingredients:	200 gr	250 gr
TC16	PRAWNS MATAR CURRY	Prawns	1½ cup	2 cup
		Green Peas	½ cup	¾ cup
		Onion	¾ cup	1 cup
		Tomato	½ cup	¾ cup
		Ginger Garlic Paste	¾ tsp	1 tsp
		Green Chilli	½ tsp	¾ tsp
		Chilli Powder	¾ tsp	1 tsp
		Turmeric Powder	¼ tsp	¼ tsp
		Garam Masala Powder	¾ tsp	1 tsp
		Coriander Leaves	2 tbsp	2 tbsp
		Salt To Taste		
		oil as required		

Method of Preparation:

"Step 1: Take a microwave oven safe bowl, add all the ingredients other than prawns, tomato, mix well, select category, enter weight, press start.

Step 2: When beep, Remove and add the remaining ingredients, mix well and press start. Remove and Serve hot."

TADKA / CURRY

Category	Recipe-	Ingredients:	200 gr	250 gr
TC17	KASHMIRI KAJU PA-NEER	Paneer Pieces	200 gr	250 gr
		Sliced Onions	¼ cup	1 cup
		Tomato Puree	¼ cup	1 cup
		Kaju Paste	3 tsp	4 tsp
		Khus Khus Paste	2 tbsp	3 tbsp
		Milk	¼ cup	1 cup
		Chopped Ginger	3 tsp	3 tsp
		Chopped Garlic	1 tsp	2 tsp
		Chilli Powder	1 tsp	1 tsp
		Garam Masala		
		Salt To Taste		
<p>Method of Preparation: "Step 1: Take a microwave oven safe bowl, add all the ingredients other than paneer, tomato puree, milk and mix well. Select category, enter weight and press start. Step 2: After the beep, remove and add the remaining ingredients, mix well and press start. Remove and Serve hot."</p>				

Category	Recipe-	Ingredients:	200 gr	250 gr
TC18	CHILI SOYA NUGGETS	Soya Nuggets, Soaked	200 gr	250 gr
		Spring Onions, Chopped	¼ cup	1 cup
		Garlic Paste	¼ tsp	1 tsp
		Green Chillies, Sliced	¼ tsp	1 tsp
		Soya Sauce	2 tsp	3 tsp
		Vinegar	¼ tsp	1 tsp
		Coriander Leaves For Garnish	2 tbsp	3 tbsp
		Salt To Taste		
		Oil As Required		
<p>Method of Preparation: "Step 1: Take a microwave oven safe bowl, add all the ingredients other than soya nuggets, soya sauce, coriander leaves and mix well. Select category, enter weight, press start. Step 2: After the beep, remove and add the remaining ingredients other than coriander leaves, mix well and press start. Remove and garnish with coriander leaves. Serve hot."</p>				

TADKA / CURRY

Category	Recipe-	Ingredients:		
TC19	MIRCHI KA SALAN	Deep fried Green chilies	200 gms	250 gms
		Onion paste	¾ cup	1 cup
		Ginger garlic paste	½ tsp	½ tsp
		Mustard seeds	½ tsp	½ tsp
		Cloves	few	few
		Curry leaves	few	few
		Tamarind pulp	¾ cup	1 cup
		Oil as required		
		Coriander leaves for garnish		
		Salt to taste		
		Salan Paste		
		Grated Coconut	¾ cup	1 cup
		Roasted Peanuts	½ cup	¾ cup
		Coriander seeds	¼ cup	½ cup
		Sesame seeds	¼ cup	½ cup
		Cumin seeds	1 tsp	1½ tsp
		Peppercorns	1 tsp	1½ tsp
		Red Chili	3	4
<p>Method of Preparation: "Grind all salan paste ingredients to make fine paste. Step 1: Take a microwave oven safe bowl, add all the ingredients other than green chilies, tamarind pulp and coriander leaves, mix well and select category, enter weight, press start. Step 2: After the beep, remove, add the remaining ingredients other than the coriander leaves and mix smoothly and press start. Finally, remove, garnish with grated coriander and serve."</p>				

TADKA / CURRY

Category	Recipe-	Ingredients:		
TC20	PRAWNS VINDALOO	Shelled Prawns	200 gms	250 gms
		Tomatoes, Chopped	1 cup	1½ cup
		Cumin Seeds	¾ tsp	1 tsp
		Ginger, Garlic Paste	1 tsp	1½ tsp
		Curry Leaves	few	few
		Chili Powder	1 tsp	1½ tsp
		Turmeric Powder	¼ tsp	¼ tsp
		Vinegar	¾ tbsp	1 tbsp
		Corn Flour	¾ tbsp	1 tbsp
		Sugar	1 tsp	1½ tsp
		Salt To Taste		
<p>Method of Preparation: "Step 1: Take a microwave oven safe bowl, add all the ingredients other than prawns and vinegar, mix well and select category, enter weight, press start. Step 2: After the beep, remove, add the remaining ingredients and mix well and press start. Remove and serve hot."</p>				

Category	Recipe-	Ingredients:	200 gr	250 gr
TC21	CRAB CURRY	Big Size Crabs	4	5
		Big Size Onion Sliced	2	2
		Red Chillies Whole	2	2
		Tamarind Pulp	1 tbsp	1½ tbsp
		Cumin Seeds	¾ tsp	1 tsp
		Coconut Scraped	1 tbsp	1½ tbsp
		Garam Masala Powder	1 tsp	1½ tsp
		Garlic & Ginger Paste	1 tsp	1 tsp
		Turmeric Powder	¼ tsp	¼ tsp
		Oil As Required		
		Water As Required		
		Salt To Taste		
<p>Method of Preparation: "Clean the crabs, only the body and claws are used (the crab claws can be lightly cracked and the body cut into half, to facilitate eating). Grind the scraped coconut with red chillies, cumin seeds, turmeric powder and garlic to a fine paste. Step 1: Take a microwave oven safe bowl, add all ingredients other than tamarind pulp and water. mix well and select category, enter weight, press start. Step 2: After the beep, remove and add tamarind pulp, water, mix well and press start. Serve hot."</p>				

TADKA / CURRY

Category	Recipe-	Ingredients:		
TC22	PAKODA CURRY	Pakodas	200 gms	250 gms
		Tomato Puree	1 cup	1½ cup
		Green Chili	2	2
		Ginger Paste	½ tsp	½ tsp
		Curry Leaves	few	few
		Mustard Seeds	½ tsp	½ tsp
		Cumin Seeds	½ tsp	½ tsp
		Hing	a pinch	a pinch
		Coriander Powder	½ tsp	½ tsp
		Red Chili Powder	½ tsp	½ tsp
		Sugar	1½ tsp	1½ tsp
		Turmeric	a pinch	a pinch
		Salt To Taste		
		Coriander Leaves For Garnish		
<p>Method of Preparation: "Step 1: Take a microwave oven safe bowl, add all the ingredients other than pakodas, tomato puree and coriander leaves, mix well and select category, enter weight, press start. Step 2: After the beep, remove, add the remaining ingredients other than the coriander leaf and mix well and press start. Remove, garnish with grated coriander and serve."</p>				

TADKA / CURRY

Category	Recipe-	Ingredients:	200 gms	250 gms
TC23	DUM ALOO	Aloo (Potatoes)	200 gms	250 gms
		Ghee	1½ tbsp	1½ tbsp
		Tomato Puree	1½ cup	1½ cup
		Curd	½ cup	½ cup
		Spices		
		Cloves	3	3
		Bay Leaves	2	2
		Black Peppercorns	5	5
		Green Cardamoms	3	3
		Brown Cardamom	3	3
		Cinnamon Stick	2	2
		Paste		
		Onion (Chopped)	2	2
		Flakes Garlic	4	4
		Ginger	½" inch	½" inch
		Black Peppercorns	5	5
		Poppy Seeds	½ tsp	½ tsp
		Coriander Seeds	½ tsp	½ tsp
		Cumin Seeds	½ tsp	½ tsp
		Dry Red Chillies	3	3
		Turmeric Powder	¼ tsp	¼ tsp
		Ground Mace	a pinch	a pinch
		Ground Nutmeg	a pinch	a pinch
		Salt To Taste		
Method of Preparation:				
"Step 1: Take a microwave oven safe bowl, add all the ingredients other than potato, tomato puree, curd and all the paste items. Mix well and select category, enter weight, press start.				
Step 2: After the beep, remove and add the remaining ingredients, mix well and press start. Remove and Serve hot."				

TADKA / CURRY

Category	Recipe-	Ingredients:		
TC24	CAPSICUM CURRY	Capsicum, Chopped	200 gms	250 gms
		Onion, Chopped	1 cup	1½ cup
		Green Chillies, Slit Lengthwise	3	4
		Ginger Paste	½ tsp	1 tsp
		Garlic Paste	½ tsp	1 tsp
		Turmeric Powder	¼ tsp	½ tsp
		Chole Masala	½ tbsp	1 tbsp
		Cumins Seeds	½ tsp	1 tsp
		Mustard Seeds	½ tsp	1 tsp
		Oil As Required		
		Salt To Taste		
		Water As Required		
<p>Method of Preparation: "Step 1: Take a microwave oven safe bowl, add all the ingredients other than capsicum, chole masala and water. Mix well and select category, enter weight, press start. Step 2: After the beep, remove and add the remaining ingredients, mix well and press start. Remove and Serve hot."</p>				

Category	Recipe-	Ingredients:	200 gms	250 gms
TC25	METHI MALAI MATAR	Green Peas	1 cup	1½ cup
		Methi Leaves	1 cup	1½ cup
		Malai / Cream	50 gms	100 gms
		Onion Paste	1 cup	1½ cup
		Green Chili Paste	1 tsp	1½ tsp
		Garlic, Ginger Paste	½ tsp	1 tsp
		Khus Khus Paste	1½ tbsp	2 tbsp
		Cumins	½ tsp	1 tsp
		Cashew Nuts	4	5
		Milk	1 cup	1½ cup
		Oil As Required		
		Salt To Taste		
<p>Method of Preparation: Step 1: Take a microwave oven safe bowl, add all the ingredients other than methi leaves, green peas, malai and milk. Mix well and select category, enter weight, press start. Step 2: After the beep, remove and add the remaining ingredients, mix well. Cover the bowl with lid and press start. Remove and Serve hot.</p>				

TADKA / CURRY

Category	Recipe-	Ingredients:		
TC26	BABY CORN MASALA	Baby Corn	200 gms	250 gms
		Tomatoes Chopped	1 cup	1½ cup
		Onion Chopped	1 cup	1½ cup
		Roasted Groundnut Powder	¼ cup	½ cup
		Chilli Powder	1 tsp	1½ tsp
		Turmeric Powder	¼ tsp	¼ tsp
		Mustard Seeds	½ tsp	¾ tsp
		Cumin Seeds	1 tsp	1½ tsp
		Fenugreek Seeds	1 tsp	1½ tsp
		Saunf	1 tsp	1½ tsp
		Salt To Taste		
		Oil As Required		
		Coriander Leaves For Garnish		
<p>Method of Preparation: "Step 1: Take a microwave oven safe bowl, add all the ingredients other than baby corn, tomatoes and coriander leaves. Mix well and select category, enter weight, press start. Step 2: After the beep, remove and add the remaining ingredients other than coriander leaf and mix well and press start. Remove and garnish with coriander leaves. Serve hot. "</p>				

Category	Recipe-	Ingredients:		
TC27	KARELA FRY	Karela (Cut Into Thin Small Rounds)	200 gms	250 gms
		Lemon Juice	1½ tsp	2 tsp
		Turmeric Powder	½ tsp	¾ tsp
		Red Chilli Powder	1 tsp	1½ tsp
		Jeera Powder	1 tsp	1½ tsp
		Garam Masala	1 tsp	1½ tsp
		Oil As Required		
		Salt To Taste		
<p>Method of Preparation: "Marinate karela with the lemon juice, turmeric, salt for 20 minutes and wash it well. Step 1: Take a microwave oven safe bowl, add all the ingredients other than garam masala, mix well and select category, enter weight, press start. Step 2: After the beep, remove and add the remaining ingredients other than coriander leaves, mix well and press start. Remove and Serve hot."</p>				

TADKA / CURRY

Category	Recipe-	Ingredients:		
TC28	CAULIFLOWER ONION FRY	Cauliflower Florets	200 gms	250 gms
		Onion Chopped	1	2
		Green Chillies	2	3
		Coriander Powder	2 tsp	3 tsp
		Lemon Juice	1 tsp	2 tsp
		Turmeric Powder	¼ tsp	¼ tsp
		Mustard Seeds	¼ tsp	½ tsp
		Cumin Seeds	½ tsp	1 tsp
		Curry Leaves	few	few
		Oil As Required		
		Salt To Taste		
<p>Method of Preparation: "Step 1: Take a microwave oven safe bowl, add all the ingredients other than cauliflower florets and salt. Mix well and select category, enter weight, press start. Step 2: After the beep, remove and add the remaining ingredients, mix well and press start. Remove and Serve hot. "</p>				

Category	Recipe-	Ingredients:		
TC29	ARBI / TARO ROOT FRY	Taro Root (Boiled & Peeled)	200 gms	250 gms
		Roasted Dalia Powder	1 cup	1½ cup
		Red Chilli Powder	1 tsp	1 tsp
		Turmeric Powder	a pinch	a pinch
		Mustard Seeds	½ tsp	½ tsp
		Cumin Seeds	1 tsp	1 tsp
		Urad Dal	3 tsp	4 tsp
		Curry Leaves	few	few
		Oil As Required		
		Salt To Taste		
<p>Method of Preparation: " Step 1: Take a microwave oven safe bowl, add all the ingredients other than taro root, salt, mix well and select category, enter weight, press start. Step 2: After the beep, remove and add the remaining ingredients, mix well and press start. Serve hot. "</p>				

TADKA / CURRY

Category	Recipe-	Ingredients:	200 gms	250 gms
TC30	GREEN CHANA CURRY	Green Chana	1 cup	1½ cup
		Tomato Chopped	1 cup	1½ cup
		Onion Chopped	1 cup	1½ cup
		Green Chilli Chopped	2	3
		Ginger, Garlic Paste	1½ tsp	2 tsp
		Cumins Powder	1 tsp	1½ tsp
		Hing	a pinch	a pinch
		Turmeric Powder	a pinch	a pinch
		Coriander Powder	1 tsp	1½ tsp
		Garam Masala	1½ tsp	2 tsp
		Oil As Required		
		Salt To Taste		
<p>Method of Preparation: "Step 1: Take a microwave oven safe bowl, add all the ingredients other than green chana and tomato. Mix well and select category, enter weight, press start. Step 2: After the beep, remove and add the remaining ingredients, mix well and press start. Serve hot. "</p>				

Category	Recipe-	Ingredients:	200 gms	250 gms
TC31	DOI MACHCH	Fish (Rohu)-sliced & rubbed with turmeric & salt	200 gms	250 gms
		Curd	1 cup	1½ cup
		Onion paste	1 cup	1½ cup
		Garlic paste	½ tsp	¾ tsp
		Ginger paste	½ tsp	¾ tsp
		Turmeric powder	¼ tsp	¼ tsp
		Chilli powder	1 tsp	1½ tsp
		Bay leaves	2	2
		Cumin seeds	½ tsp	¾ tsp
		Cardamoms	3	4
		Cloves	2	3
		Cinnamon-broken	1	2
		Sugar	1 tsp	1½ tsp
		Oil as required		
		Salt to taste		
<p>Method of Preparation: "Step 1: Take a microwave oven safe bowl, add all the ingredients other than fish, curd, and sugar. Mix well and select category, enter weight, press start. Step 2: After the beep, remove and add all the remaining ingredients, mix well and press start. Serve hot. "</p>				

TADKA / CURRY

Category	Recipe-	Ingredients:	200 gms	250 gms
TC32	TAMATAR KA SHORBA	Tomatoes, Chopped	1 cup	1½ cup
		Chopped Ginger	½ tsp	¾ tsp
		Chopped Garlic	½ tsp	¾ tsp
		Green Chili	½ tsp	¾ tsp
		Garam Masala	½ tsp	¾ tsp
		Bay Leaf	2	3
		Chopped Green Coriander	2 tbsp	2½ tbsp
		Cumin Seeds	½ tsp	¾ tsp
		Sugar	½ tsp	¾ tsp
		Salt To Taste		
		Oil As Required		
<p>Method of Preparation: "Step 1: Take a microwave oven safe bowl, add all ingredients other than tomatoes, sugar, mix well and select category, enter weight, press start. Step 2: After the beep, remove and add all the remaining ingredients, mix well and press start. Serve hot."</p>				

Category	Recipe-	Ingredients:	200 gms	250 gms
TC33	MATAR MUSHROOM	Mushrooms, cut in to halves	1 cup	1½ cup
		Green peas	½ cup	¾ cup
		Tomato puree	½ cup	¾ cup
		cardamoms	3	4
		cinnamon	2	3
		Chopped onion	½ cup	¾ cup
		Ginger garlic paste	½ tsp	¾ tsp
		Chilli powder	½ tsp	¾ tsp
		Coriander powder	½ tsp	¾ tsp
		Turmeric powder	⅛ tsp	¼ tsp
		Garam masala	½ tsp	¾ tsp
		Cashew nuts paste	1 tbsp	1½ tbsp
		Salt to taste		
		Oil as required		
		Chopped coriander for garnish		
<p>Method of Preparation: "Step 1: Take a microwave oven safe bowl, add all ingredients other than mushrooms, green peas, tomato puree and garnish ingredient, mix well and category, enter weight, press start. Step 2: After the beep, remove and add all remaining ingredients other than coriander, mix well and press start. Garnish with coriander. Serve hot."</p>				

TADKA / CURRY

Category	Recipe-	Ingredients:	200 gms	250 gms
TC34	GOBI SUBZI	Cauliflower Florets	½ cup	¾ cup
		Green Peas	½ cup	¾ cup
		Chopped Cabbage	½ cup	¾ cup
		Green Chillies	2	3
		Cashew Nut Paste	½ cup	¾ cup
		Garam Masala	1½ tsp	2 tsp
		Curd	1 cup	1½ cup
		Oil As Required		

Method of Preparation:

" Step1: Take a microwave oven safe bowl, add all ingredients other than cabbage, green peas and curd, mix well and select category, enter weight, press start.

Step 2: After the beep, remove and add all remaining ingredients, mix well and press start. Serve hot."

Category	Recipe-	Ingredients:		
TC35	METHI ALOO	Methi leaves (chopped)	2 cups	3 cups
		Big size potato (cut in pieces)	1 no.	2 nos.
		Tomato (chopped)	1 no.	2 nos.
		Oil	1 tbsp	1½ tbsp
		Green chilli (chopped)	1 no.	2 nos.
		Red chilli powder, haldi	1 tsp	1½ tsp
		Turmeric powder	¼ tsp	¼ tsp
		Garam masala	1 tsp	1½ tsp
		Salt to taste		

Method of Preparation:

"Step 1: In a microwave oven safe bowl add all ingredients other than methi leaves, tomato, mix well. Select category & weight and press start.

Step 2: When the oven beeps, remove and add all other remaining ingredients, mix well and cover the bowl with lid. Press start. Serve hot."

TADKA / CURRY

Category	Recipe-	Ingredients:		
TC36	CURD BRINJAL	Brinjal (cut into pieces)	200 g	250 g
		Curd	150 g	200 g
		Chopped ginger	¾ tsp	1 tsp
		Curry leaves	2 tsp	3 tsp
		Mustard seeds	¾ tsp	1 tsp
		Cumins seeds	¾ tsp	1 tsp
		Oil as required		
		Salt to taste		
<p>Method of Preparation: "Step 1: In a microwave oven safe bowl add all ingredients other than curd, mix well. Select category & weight and press start. Step 2: When the oven beeps, remove and add other remaining ingredients, mix well and press start. Serve hot."</p>				

Category	Recipe-	Ingredients:		
TC37	BROCCOLI CURRY	Broccoli, Chopped	200 g	250 g
		Onions, Chopped	¾ cup	1 cup
		Chili Powder	1 tsp	1 tsp
		Black Pepper	few	few
		Cumin	1 tsp	1 tsp
		Coriander Powder	1 tsp	1 tsp
		Turmeric	¼ tsp	¼ tsp
		Dried Coconut	½ cup	½ cup
		Lemon Juice	1 tsp	1 tsp
		Butter	2 tbsps	3 tbsps
		Salt To Taste		
<p>Method of Preparation: "Step 1: In a microwave oven safe bowl add all ingredients other than braccoli, lime juice, mix well. Select category & weight and press start. Step 2: When the oven beeps, remove and add other remaining ingredients, mix well and press start. Serve hot."</p>				

TADKA / CURRY

Category	Recipe-	Ingredients:		
TC38	KEEMA PALAK	Chicken Minced	200 g	250 g
		Spinach, Chopped	¾ cup	1 cup
		Onion, Finely Chopped	¾ cup	1 cup
		Tomato Puree	½ cup	½ cup
		Green Chilli, Finally Chopped	2	3
		Ginger Garlic Paste	1 tsp	1 tsp
		Cumins	1 tsp	1 tsp
		Bay Leaf	few	few
		Garam Masala	1 tsp	1 tsp
		Oil As Required		
		Salt To Taste		
<p>Method of Preparation: "Step 1: In a microwave oven safe bowl add all ingredients other than chicken, tomato puree, mix well. Select category & weight and press start. Step 2: When the oven beeps, remove and add other remaining ingredients, mix well and press start. Serve hot."</p>				

Category	Recipe-	Ingredients:	200 gr	250 gr
TC39	ALOO GOBI	Cauliflower Florets	¾ cup	1 cup
		Potatoes Sliced	¾ cup	1 cup
		Ginger Chopped	1 tsp	1 tsp
		Turmeric Powder	¼ tsp	¼ tsp
		Red Chilli Powder	1 tsp	1 tsp
		Garam Masala	1 tsp	1 tsp
		Oil As Required		
		Salt To Taste		
		Coriander Leaves For Garnish		
<p>Method of Preparation: "Step 1: In a microwave oven safe bowl add all ingredients other than cauliflower, coriander leaves, mix well. Select category & weight and press start. Step 2: When the oven beeps, remove and add other remaining ingredients other than coriander leaves, mix well and press start. Garnish with coriander leaves. Serve hot."</p>				

TADKA / CURRY

Category	Recipe-	Ingredients:		
TC40	BEANS PORIAL	French beans chopped	200 gr	250 gr
		Urad dhal	2 tsp	3 tsp
		Grated coconut	¼ cup	1 cup
		Mustard seeds	1 tsp	1 tsp
		Green chillies	1 tsp	1 tsp
		Salt to taste		
		Oil as required		
<p>Method of Preparation: "Step 1: In a microwave oven safe bowl add all ingredients other than french beans, mix well. Select category & weight and press start. Step 2: When the oven beeps, remove and add other remaining ingredients, mix well and press start. Serve hot."</p>				

INDIA'S BEST RECIPES

Category	Recipe-	Ingredients:		
IB1	KASHMIRI PULLAO	Basmati Rice Soaked	1cup	1½ cup
		Cinnamon Stick	3	3
		Shahjeera	¼ tsp	1 tsp
		Tej Patta	3	3
		Cloves	few	few
		Cardamoms	4	4
		Dry Ginger Powder	½ tsp	½ tsp
		Fennel Powder	¼ tsp	1 tsp
		Ghee	2 tbsp	2 tbsp
		Water As Required		
		Salt As Required		
		For Garnishing Pulao:		
		Onion, Sliced Thinly	1	1
		Cashews	4	6
		Almonds	4	5
		Walnuts	3	5
		saffron	a pinch	a pinch
Method of Preparation:				
"Step 1: In a microwave oven safe bowl add all ingredients other than water, garnish ingredients, mix well. Select category & weight and press start.				
Step 2: When the oven beeps, remove and add water, mix well and press start. Remove and garnish with onions, cashew, almonds, saffron and Serve hot."				

INDIA'S BEST RECIPES

Category	Recipe-	Ingredients:	Weight 1	Weight 2
IB2	BISI BELE BATH	Red gram dal	½ cup	½ cup
		Rice	¾ cup	1 cup
		Brinjal chopped	2	2
		Tamarind juice	1/4 cup	½ cup
		Hing	a pinch	a pinch
		Oil as required		
		Salt to taste		
		Water as required		
		Paste ingredients		
		Onion	1	1
		Green chillies	¾ tsp	1 tsp
		Cashew nuts	¼cup	½ cup
		Grated coconut	¼cup	½ cup
		Khus khus	¼cup	½ cup
		Curry leaves	few	few
		Coriander leaves	¼cup	½ cup
		Powdered ingredients		
		Dry red chillies	2	3
		Fenugreek seeds	¾ tsp	1 tsp
		Coriander seeds	½ tsp	½ tsp
		Mustard	½ tsp	½ tsp
		Cardamoms	2	3
		Cinnamon	1	1
		Cloves	2	3
		Saunf	1 tsp	1 tsp

Method of Preparation:

"Step 1: In a microwave oven safe bowl add oil, add all paste and powder ingredients other than rice, dal, brinjal, water, mix well. Select category & weight and press start.

Step 2: When the oven beeps, remove and add all remaining ingredients, mix well and press start. Serve hot."

INDIA'S BEST RECIPES

Category	Recipe-	Ingredients:	Weight 1	Weight 2
IB3	VEGETABLE BIRYANI	Rice	1 cup	1½ cup
		Ghee	1 tbsp	1 tbsp
		Carrot Chopped	¼ cup	¼ cup
		French Beans Chopped	¼ cup	¼ cup
		Green Peas	¼ cup	¼ cup
		Red Chilli Powder	½ tsp	½ tsp
		Garam Masala	¼ tsp	¼ tsp
		Garlic Paste	¼ tsp	¼ tsp
		Ginger Paste	¼ tsp	¼ tsp
		Green Chillies Chopped	¼ tbsp	¼ tbsp
		Onion Chopped	1	1
		Tomato Chopped	1	1
		Cinnamon	½ inch	½ inch
		Cloves	4	4
		Cardamom	4	4
		Coconut Milk	1cup	1cup
		Cashew Nuts	few	few
		Mint Leaves	few	few
		Coriander Leaves	few	few
		Lemon Juice	½ tsp	½ tsp
		Salt To Taste		
		Water As Required		
<p>Method of Preparation: "Step 1: In a microwave oven safe bowl add all ingredients other than rice, tomato, coconut milk, water, cashew nuts, mint leaves, coriander leaves, lemon juice and salt. Mix well, select category, enter weight, press start. Step 2: When the oven beeps, remove, add the remaining ingredients, mix well and press start. Serve hot."</p>				

INDIA'S BEST RECIPES

Category	Recipe-	Ingredients:	Weight 1	Weight 2
IB4	VEG- PULLAO	Rice (Soaked)	¾ cup	1 cup
		Potato Cut Into Cubes	¼ cup	½ cup
		Carrot Cut Into Cubes	¼ cup	½ cup
		Cauliflower Cut Into Florets	¼ cup	½ cup
		Peas	¼ cup	½ cup
		Cashew Nuts	½ tbsp	½ tbsp
		Raisins	¾ cup	1 tsp
		Onions	1	1
		Ghee	1 tbsp	2 tbsp
		Oil	1 tsp	1 tsp
		Turmeric Powder	¼ tsp	¼ tsp
		Ginger Paste	½ tsp	½ tsp
		Garlic Paste	½ tsp	½ tsp
		Green Chilli Paste	½ tsp	½ tsp
		Cinnamon Stick	1	2
		Cloves	2	3
		Mint Leaves	¼ tbsp	¼ tbsp
		Cardamom	2	3
		Water As Required		
		Salt To Taste		

Method of Preparation:

"Step 1: In a microwave oven safe bowl add all ingredients other than rice, water and salt. mix well. Select category & weight and press start.

Step 2: When the oven beeps, remove, add the remaining ingredients and mix well and press start. Serve hot."

INDIA'S BEST RECIPES

Category	Recipe-	Ingredients:	Weight 1	Weight 2
IB5	JEERA RICE	Rice	1cup	1½ cup
		Jeera (Cumin Seeds)	1 tsp	2 tsp
		Cashew Nuts	1 tbsp	2 tbsp
		Peppercorns	3	4
		Bay Leafs	2	2
		Cloves	2	3
		Cinnamon Sticks	2	2
		Onions, Sliced	1	1
		Ghee As Required		
		Salt To Taste		
		Water As Required		

Method of Preparation:

"Step 1: In a microwave oven safe bowl add all ingredients other than rice and water. Mix well. Select category & weight and press start. Step 2: When the oven beeps, remove, add the remaining ingredients, mix well and press start. Serve hot."

Category	Recipe-	Ingredients:	Weight 1	Weight 2
IB6	MUTTON CURRY	Mutton	1½ cup	2 cup
		Tomato (Chopped)	¾ cup	1 cup
		Red chili powder	1 tsp	1½ tsp
		Onions (Chopped)	½ cup	1 cup
		Black Pepper Powder	½ tsp	¾ tsp
		Turmeric Powder		
		Cinnamon	1 tsp	1½ tsp
		Coriander seeds	1 tsp	1½ tsp
		Cumin seeds	¾ tsp	¾ tsp
		Cloves	3	3
		Green Cardamoms	3	4
		Ginger and Garlic Paste.	1 tsp	1½ tsp
		Curry Leaves	few	few
		Poppy Seeds	few	few
		Fennel Seeds	½ tsp	¾ tsp
		Black Peppercorns	½ tsp	¾ tsp
		Oil as required		
		Salt to taste		
		Coriander Leaves for garnish		

Method of Preparation:

"Step 1: In a microwave oven safe bowl add all ingredients other than mutton, tomato and coriander leaves. Mix well. Select category & weight and press start. Step 2: When the oven beeps, remove, add the remaining ingredients other than coriander leaves, mix well and press start. Remove and garnish with coriander leaves. Serve hot."

INDIA'S BEST RECIPES

Category	Recipe-	Ingredients:	Weight 1	Weight 2
IB7	GOSHT DUM BIRYANI	Basmati rice (soaked for 1 hour)	¾ cup	1 cup
		Boneless mutton	1¾ cup	2 cup
		Chopped onion	¾ cup	1 cup
		Ginger garlic paste	¾ tsp	1 tsp
		Cumins	¾ tsp	1 tsp
		red chilli powder	¾ tsp	1 tsp
		Garam masala	¾ tsp	1 tsp
		Turmeric powder	¼ tsp	¼ tsp
		Cloves	few	few
		Bay leaves	few	few
		Salt to taste		
		Water as required		
		Oil as required		
<p>Method of Preparation: "Step 1: In a microwave oven safe bowl add oil, jeera, laung, tej patta onion, ginger garlic paste, mutton & cover. Select category & weight and press start. Step 2: When the oven beeps, mix well. Add rice, water, salt, red chilli powder, garam masala & cover. Press start. Serve hot."</p>				

INDIA'S BEST RECIPES

Category	Recipe-	Ingredients:	Weight 1	Weight 2
IB8	RASAM	Red Gram Dal	1 cup	1½ cup
		Tomatoes	2	2
		Garlic Paste	½ tsp	½ tsp
		Garlic Grated	½ tsp	½ tsp
		Ginger Chopped	½ inch	½ inch
		Green Chillies Chopped	1	1
		Turmeric Powder	¼ tsp	¼ tsp
		Mustard Seeds	½ tsp	½ tsp
		Cumin Seeds	½ tsp	½ tsp
		Dried Red Chillies	2	2
		Hing	a pinch	a pinch
		Curry Leaves	few	few
		Pepper Powder	½ tsp	½ tsp
		Oil	1 tbsp	2 tbsp
		Salt To Taste		
		Water As Required		
		Coriander Leaves For Garnish		

Method of Preparation:

"Step 1: In a microwave oven safe bowl add all ingredients other than red gram dal, tomato, water and coriander leaves. Mix well. Select category & weight and press start.

Step 2: When the oven beeps, remove, add the remaining ingredients other than coriander leaf and mix well and press start. Remove, garnish with coriander leaves and serve hot."

INDIA'S BEST RECIPES

Category	Recipe-	Ingredients:	Weight 1	Weight 2
IB9	SAMBHAR	Red Gram Dal	1 cup	1½ cup
		Turmeric Powder	¼ tsp	¼ tsp
		Bitter Gourd (Sliced Into Long Pieces)	½ cup	¾ cup
		Brinjal (Sliced Into Long Pieces)	½ cup	¾ cup
		Drum Stick (Sliced Into Long Pieces)	½ stick	½ stick
		Ladies Finger (Sliced Into Long Pieces)	½ cup	3
		Dried Red Chillies	3	4
		Curry Leaves	few	few
		Tamarind	½ cup	¾ cup
		Hing	¼ tsp	¼ tsp
		Red Chilli Powder	1 tsp	1 tsp
		Oil	1½ tbsp	2 tbsp
		White Gram Dal (Fried)	1 tsp	1 tsp
		Coriander Seeds (Fried)	½ tbsp	½ tbsp
		Mustard Seeds (Fried)	½ tsp	½ tsp
		Coriander Leaves For Garnish		
		Mustard Seeds For Tadka		
		Water		
		Salt To Taste		
<p>Method of Preparation: "Make a paste of fried white gram dal, coriander seeds, mustard seeds. Keep it aside. Mash the tamarind in a cup of water and strain. Keep it aside. Step 1: Take a microwave oven safe bowl add all the ingredients other than red gram dal and water. Mix well. Select category & weight and press start. Step 2: When the oven beeps, remove, add the remaining ingredients, mix well and press start. Serve hot."</p>				

INDIA'S BEST RECIPES

Category	Recipe-	Ingredients:	Weight 1	Weight 2
IB10	ZAFRANI PULAO	Basmati Rice	1 cup	1½ cup
		Water	1½ cup	2 cup
		Sugar	2 tbsp	3 tbsp
		Milk	1 cup	1½ cup
		Cashews	½ cup	¾ cup
		Cardomoms	4	5
		Cloves	few	few
		Cinnamon, Broken	few	few
		Almonds, Blanched And Cut	½ cup	¾ cup
		Saffron Strands, Soaked In Hot Milk	1 tsp	1½ tsp
		Ghee As Required		
<p>Method of Preparation: "Step 1: Take a microwave oven safe bowl, add all ingredients other than water, mix well and select category, enter weight and press start. Step 2: When the oven beeps, remove and add water, mix well and press start. Serve hot."</p>				

Category	Recipe-	Ingredients:	Weight 1	Weight 2
IB11	DAL TADKA	Red Lentils (Masoor Dal)	¾ cup	1 cup
		Yellow Lentils (Moong Dal)	¾ cup	1 cup
		Tomato Chopped	2	2
		Onion Chopped	1	1
		Oil	1 tbsp	1 tbsp
		Red Chilli Powder	1 tsp	1 tsp
		Turmeric Powder	¼ tsp	¼ tsp
		Ginger Paste	½ tsp	½ tsp
		Garlic Paste	½ tsp	½ tsp
		Green Chillies Chopped	2	2
		Mustard Seeds	¼ tsp	¼ tsp
		Dried Red Chillies	2	2
		Coriander Leaves For Garnish		
		Salt To Taste		
		Water As Required		
<p>Method of Preparation: "Step 1: In a microwave oven safe bowl add all ingredients other than red lentils, yellow lentils, tomato, water and salt. Mix well. Select category & weight and press start. Step 2: When the oven beeps, remove, add the remaining ingredients, mix well and press start. Serve hot."</p>				

INDIA'S BEST RECIPES

Category	Recipe-	Ingredients:	Weight 1	Weight 2
IB12	CHICKEN CHETTINAD	Chicken	150 gms	200 gms
		Khus Khus Roasted	1 tbsp	2 tbsp
		Dry Red Chillies Roasted	2	3
		Coriander Roasted	½ tsp	½ tsp
		Mustard Roasted	½ tbsp	1 tbsp
		Cinnamon Roasted	½ inch	1 inch
		Cardamom Roasted	2	2
		Cloves Roasted	2	2
		Chilli Powder	1 tsp	1 tsp
		Turmeric Powder	½ tsp	½ tsp
		Chopped Ginger	1 tsp	1 tsp
		Chopped Garlic	1 tsp	1 tsp
		Chopped Tomato	1	1
		Chopped Onions	1	1
		Oil	1 tbsp	1 tbsp
		Curry Leaves	few	few
		Lemon Juice	½ tsp	½ tsp
		Sugar	½ tsp	½ tsp
		Grated Coconut for Garnish		
		Coriander Leaves for Garnish		
		Salt To Taste		
<p>Method of Preparation: "In a mixer, grind all the roasted ingredients with garlic and ginger to make a uniform paste. Step 1: Take a microwave oven safe bowl add all the ingredients other than chicken, tomato, coconut and coriander leaves. Mix well. Select category & weight and press start. Step 2: When the oven beeps, remove, add the remaining ingredients except coconut and coriander leaves, mix well and press start. Remove, garnish with coconut and coriander. Serve hot."</p>				

INDIA'S BEST RECIPES

Category	Recipe-	Ingredients:	Weight 1	Weight 2
IB13	RIDGE GUARD CURRY	Ridge Gourd (Peeled & Chopped)	1½ cup	2 cup
		Moong Dal	¼ cup	½ cup
		Urad Dal	¼ cup	½ cup
		Jeera	¾ tsp	¾ tsp
		Mustard Seeds	½ tsp	½ tsp
		Red Chilli Powder	1 tsp	1½ tsp
		Onion (Chopped)	1 cup	1½ cup
		Curry Leaves	few	few
		Whole Red Chillies	2	3
		Turmeric Powder	¼ tsp	¼ tsp
		Fresh Coconut	¼ cup	½ cup
		Hing	a pinch	a pinch
		Oil As Required		
		Salt To Taste		

Method of Preparation:

"Step 1: Take a microwave oven safe bowl, Add all ingredients other than ridge gourd, salt. Mix well. Select category & weight and press start.

Step 2: When the oven beeps, remove the bowl, add the remaining ingredients mix well and press start. Remove and serve."

Category	Recipe-	Ingredients:		
IB14	FISH MASALA	Fish	200 g	250 g
		Onion Chopped	1 cup	1½ cup
		Tomato Chopped	½ cup	1 cup
		Green Chillies, Chopped	½ tsp	1 tsp
		Coriander Leaves	2 tbsp	3 tbsp
		Garam Masala	1 tsp	1 tsp
		Turmeric Powder	⅙ tsp	⅙ tsp
		Coriander Powder	½ tsp	1 tsp
		Chili Powder	1 tsp	1 tsp
		Lemon Juice	½ tsp	½ tsp
		Ginger-Garlic Paste	½ tsp	½ tsp
		Water As Required		
		Oil As Required		
		Salt to taste		

Method of Preparation:

"Step 1: Take a microwave oven safe bowl, Add all ingredients other than fish, tomato, coriander leaves, water, mix well and select category, enter weight, press start.

Step 2: When the oven beeps, remove and add all remaining ingredients, mix well and press start. Serve hot."

INDIA'S BEST RECIPES

Category	Recipe-	Ingredients:		
IB15	BUTTER CHICKEN	Boneless Chicken	200gms	250gms
		Yogurt	3 tbsp	4 tbsp
		Lime Juice	1 tsp	1 tsp
		Red Chilli Powder	1 tsp	1½ tsp
		Roasted Cloves	2	3
		Roasted Pepper Corns	2	3
		Roasted Cinnamon	½ inch	1 inch
		Cardamom	2	3
		Roasted Almonds	3	4
		Bay Leaves	2	3
		Oil	1½ tbsp	2 tbsp
		Chopped Onions	1	1
		Garlic Paste	½ tsp	½ tsp
		Ginger Paste	½ tsp	½ tsp
		Coriander Powder	½ tsp	½ tsp
		Cumin Powder	½ tsp	½ tsp
		Turmeric Powder	¼ tsp	¼ tsp
		Tomato Puree	2 tbsp	3 tbsp
		Chicken Stock	¾ cup	1 cup
		Kasuri Methi	1 tsp	1 tsp
		Butter	2 tbsp	3 tbsp
		Salt To Taste		
		coriander leaves for garnish		

Method of Preparation:

"Grind & make a paste of cloves, pepper corns, cinnamon, almonds & cardamom. Marinate the chicken with the above paste and butter, yogurt, salt, lime juice, red chilli powder, bay leaves, coriander, cumin, turmeric powder & set aside for 1 hour.

Step 1: Take a microwave oven safe bowl, Add oil, onion, garlic, ginger paste, mix well, select category, enter weight, press start.

Step 2: When the oven beeps, remove, add the remaining ingredients and mix well and press start. Remove and garnish with coriander leaves and serve."

INDIA'S BEST RECIPES

Category	Recipe-	Ingredients:	Weight 1	Weight 2
IB16	SHAHI PANEER	Paneer (Cut In Thin Slices)	1½ cup	2 cups
		Milk	¾ cup	1 cup
		Turmeric Powder	¼ tsp	¼ tsp
		Fennel (Saunf) Grinded	2 tbsp	3 tbsp
		Bay Leaves	3	4
		Cardamoms	2	3
		Sticks Cinnamon	1tsp	1tsp
		Cumin Seeds	½ tsp	1 tsp
		Fresh Seedless Green Chilies		
		Salt To Taste		

Method of Preparation:

Step 1: Take a microwave oven safe glass bowl, add all the ingredients other than paneer slices, fennel (Saunf powder), milk and mix well, select category, enter weight, press start. Step 2: When the oven beeps, remove, add all remaining ingredients and mix well smoothly and press start. Remove and serve.

Category	Recipe-	Ingredients:		
IB17	KARELA KA SUBJI	Karela, Chopped	200 gms	250 gms
		Onion, Finely Chopped	¾ cup	1 cup
		Besan	1½ tbsp	2 tbsp
		Green Chilli, Finely Chopped	3	4
		Ginger, Garlic Paste	1 tsp	1½ tsp
		Fresh Coriander, Chopped	few	few
		Oil As Required	2 tbsp	3 tbsp
		Red Chilli Powder	1 tsp	1½ tsp
		Coriander Powder	1 tsp	1 tsp
		Turmeric Powder	¼ tsp	¼ tsp
		Amchoor Powder	½ tsp	½ tsp
		Cumin Seeds	½ tsp	1 tsp
		Hing	a pinch	a pinch
		Salt To Taste		

Method of Preparation:

"Step 1: Take a microwave oven safe glass bowl, add all the ingredients other than karela and besan and mix well, select category, enter weight, press start.

Step 2: When the oven beeps, remove, add the remaining ingredients and mix well and press start. Remove and serve."

INDIA'S BEST RECIPES

Category	Recipe-	Ingredients:	Weight 1	Weight 2
IB18	POTATO CURRY	Potatoes, Peeled And Cubed	1½ cup	2 cup
		Tomatoes, Chopped	1 cup	1½ cup
		Onion, Chopped	1 cup	1½ cup
		Garlic, Ginger Paste	¾ tsp	1 tsp
		Chili Powder	1 tsp	1½ tsp
		Coriander Powder	1 tsp	1½ tsp
		Cumin Seeds	1 tsp	1½ tsp
		Turmeric Powder	¼ tsp	¼ tsp
		Ghee As Required		

Method of Preparation:

"Step 1: Take a microwave oven safe bowl, add all the ingredients other than potato and tomatoes. Mix well, select category, enter weight, press start.

Step 2: When the oven beeps, remove, add the all remaining ingredients, mix well and press start. Remove and serve hot."

Category	Recipe-	Ingredients:		
IB19	GOAN FISH CURRY	Fish	200 gms	250 gms
		Fried onion, paste	1 cup	1½ cup
		Tomato puree	¾ cup	1 cup
		Ginger-Garlic paste	1 tsp	1½ tsp
		Goan fish masala	1½ tsp	2 tsp
		Tamarind paste	½ cup	¾ cup
		Cumin	1 tsp	1 tsp
		Peppercorns	few	few
		Cloves	few	few
		Red chillies whole	2	3
		Red chili powder	1 tsp	1 tsp
		Turmeric powder	¼ tsp	¼ tsp
		Lemon juice	1 tsp	1 tsp
		Sugar	½ tsp	½ tsp
		Oil as required		
		Salt to taste		
		Chopped coriander for garnish- ing		

Method of Preparation:

"Step 1: Take a microwave oven safe bowl, add all the ingredients other than fish, tomato puree, tamarind paste, lemon juice, coriander leaves, mix well, select category, enter weight, press start.

Step 2: When the oven beeps, remove and add the all remaining ingredients other than coriander leaves, mix well and press start. Remove and garnish with coriander leaves. Serve hot."

INDIA'S BEST RECIPES

Category	Recipe-	Ingredients:		
IB20	ACHARI CHICKEN	Boneless chicken	200 g	250 g
		Fennel seeds	¼ tsp	1 tsp
		Chili powder	¼ tsp	1 tsp
		Kalonji	¼ tsp	1 tsp
		Mustard seeds	½ tsp	1 tsp
		Cumin	¼ tsp	1 tsp
		Fenugreek seeds	½ tsp	1 tsp
		Ginger, Garlic paste	1 tsp	1½ tsp
		Turmeric powder	¼ tsp	¼ tsp
		Dry red chillies	3	4
		Vinegar	2 tbsp	2 tbsp
		Salt to taste		

Method of Preparation:

Step 1: Take a microwave oven safe bowl, add all the ingredients other than vinegar and salt. Mix well, select category, enter weight, press start, Step 2: When the oven beeps, remove and add the all remaining ingredients, mix well and press start. Remove and serve hot.

Category	Recipe-	Ingredients:	Weight 1	Weight 2
IB21	CHICKEN STEW	Chicken (Cut In To Pieces)	2 cups	2½ cups
		Potatoes (Cut In To Pieces)	½ cup	¾ cup
		Carrot Medium (Cut In To Pieces)	½ cup	¾ cup
		Onion (Cut In To Pieces)	½ cup	1 cup
		Tiny Pearl Onions (Peeled)	½ cup	¾ cup
		French Beans (Cut In To Pieces)	½ cup	½ cup
		Cauliflower Florets	½ cup	½ cup
		Garlic (Crushed)	few	few
		Corn Flour	½ cup	¾ cup
		Bay Leaves	few	few
		Parsley	1½ tbsp	2 tbsp
		Celery Stalk (Lightly Crushed)	1½ tbsp	2 tbsp
		Dried Thyme	few	few
		Block Pepper Corns (Crushed)	few	few
		Salt To Taste		
		Oil As Required		
		Water As Required		

Method of Preparation:

"Step 1: Take a microwave oven safe glass bowl, add all the ingredients other than chicken. Mix well and select category, enter weight, press start. Step 2: When the oven beeps, Remove and add remaining ingredients, mix well and Press start. Serve hot."

INDIA'S BEST RECIPES

Category	Recipe-	Ingredients:	Weight 1	Weight 2
IB22	AVIAL	Carrot	½ cup	¾ cup
		Potato	½ cup	¾ cup
		Drumstick	½ cup	¾ cup
		French beans	½ cup	¾ cup
		Bottlegourd	½ cup	¾ cup
		Coconut milk	½ cup	¾ cup
		Curd (beaten)	½ cup	¾ cup
		Curry leaves	few	few
		Mustard seeds	½ tsp	1 tsp
		Turmeric powder	¼ tsp	¼ tsp
		Salt to taste		
		Oil as required		
Method of Preparation:				
"Step 1: Take a microwave oven safe glass bowl, add all the ingredients other than coconut milk, curd and mix well and select category, enter weight, press start.				
Step 2: When the oven beeps, Remove and add remaining ingredients, mix well and Press start. Serve hot. "				

Category	Recipe-	Ingredients:		
IB23	BEAN SPROUTS	Mixed Bean Sprouts	200 gms	250 gms
		Onion Chopped	1 cup	1½ cup
		Tomato Chopped	¾ cup	1 cup
		Cumin Seeds	½ tsp	1 tsp
		Ginger, Garlic Paste	1 tsp	1½ tsp
		Green Chilies - Chopped	2	3
		Cumin Powder	1 tsp	1 tsp
		Coriander Powder	½ tsp	1 tsp
		Garam Masala	½ tsp	1 tsp
		Turmeric Powder	¼ tsp	¼ tsp
		Asafoetida	¼ tsp	¼ tsp
		Water As Required		
		Oil As Required		
		Coriander Leaves For Garnish		
		Salt To Taste		
Method of Preparation:				
"Step 1: Take a microwave oven safe glass bowl, add all the ingredients other than bean sprouts, tomato, water, coriander leaves. Mix well and select category, enter weight, press start.				
Step 2: When the oven beeps, remove and add remaining ingredients other than coriander leaves, mix well and Press start. Remove and garnish with coriander leaves, Serve hot."				

INDIA'S BEST RECIPES

Category	Recipe-	Ingredients:	Weight 1	Weight 2
IB24	USAL	Soaked pea	1½ cup	2 cup
		Garam masala	1 tbsp	2 tbsp
		Roasted jeera	1 tsp	2 tsp
		Turmeric powder	¼ tsp	¼ tsp
		Oil	2 tbsp	3 tbsp
		Salt to taste		
		Water as required		
		For Paste		
		Coriander leaves	1 cup	1½ cup
		Grated coconut	¾ cup	1 cup
		Green chilli	3 nos.	4 nos.
		Water (to make the paste)		

Method of Preparation:

"Make a paste of coriander leaves, grated coconut, green chilli, adding required amount of water in a mixer.

Step 1: Take a microwave oven safe bowl take oil, roasted jeera & coriander paste. Mix well. Select category & weight and press start. Step 2: When the oven beeps, add boiled peas, all the spices & water. Mix well and press start. Serve usal garnished with grated coconut & serve with pav. "

Category	Recipe-	Ingredients:		
IB25	MISAL PAV	Mixed Sprouts	200 gms	250 gms
		Tomato Puree	1 cup	1½ cup
		Chilli Powder	1 tsp	1 tsp
		Jeera	½ tsp	1 tsp
		Ginger Garlic Paste	1 tsp	1½ tsp
		Cumin Powder	½ tsp	1 tsp
		Misal Masala	1 tsp	1½ tsp
		Turmeric Powder	¼ tsp	¼ tsp
		Sugar	½ tsp	1 tsp
		Cloves	few	few
		Cinnamon Powder	¼ tsp	½ tsp
		Oil As Required		
		Coriander For Garnishing		
		Salt To Taste		
		Water As Required		

Method of Preparation:

Step 1: Take a microwave oven safe bowl, add all ingredients other than tomato puree, coriander leaves, mix well, select category, enter weight, press start. Step 2: When the oven beeps, remove and add all remaining ingredients other than coriander leaves, mix well & press start. Garnish with coriander leaves.

INDIA'S BEST RECIPES

Category	Recipe-	Ingredients:	Weight 1	Weight 2
IB26	KADAI CHICKEN	To marinate:		
		Chicken	200 gms	250 gms
		Red chilly powder	1 tsp	1 tsp
		Turmeric powder	¼ tsp	½ tsp
		Ginger garlic paste	1 tsp	1 tsp
		Lemon juice	1 tbsp	1 tbsp
		Salt to taste		
		To prepare Gravy:		
		Onion	1 cup	1½ cup
		Tomato	¾ cup	1 cup
		Chopped capsicum	½ cup	½ cup
		Cardamom	2	2
		Cloves	3	3
		Cinnamon	1	1
		Star anise	1	1
		Ginger garlic paste	1 tsp	1 tsp
		Coriander powder	½ tsp	½ tsp
		Cumin powder	½ tsp	½ tsp
		Bay leaf	3	3
		Red chilly powder	½ tsp	½ tsp
		Oil	2 tbsp	2 tbsp
		Coriander leaves for garnish		
		Salt to taste		
<p>Method of Preparation: "Marinate the chicken with all marinate ingredients for 20 minutes. Step 1: Take a microwave oven safe bowl, add all ingredients other than marinated chicken, tomato, coriander leaves, mix well and select category, enter weight, press start. Step 2: When the oven beeps, remove and add all remaining ingredients other than coriander leaves, mix well & Press start. Garnish with coriander leaves. Serve hot."</p>				

INDIA'S BEST RECIPES

Category	Recipe-	Ingredients:	Weight 1	Weight 2
IB27	SARSON KA SAG	Sarson (Green Mustard) Chopped	1½ cup	2 cup
		Palak Chopped	1½ cup	2 cup
		Onion Chopped	3	4
		Garlic, Ginger Paste	1½ tsp	2 tsp
		Green Chillies (Finely Chopped)	1½ tsp	2 tsp
		Makkai Ka Atta (Corn Flour)	1½ tbsp	2 tbsp
		Powdered Gul (Jaggery)	1½ tbsp	2 tbsp
		Red Chilli Powder	1½ tsp	2 tsp
		Ghee As Required		
		Salt To Taste		

Method of Preparation:

"Step 1: Take a microwave oven safe bowl, add all ingredients other than sarson, spinach, corn flour, mix well and select category, enter weight, press start.

Step 2: When the oven beeps, remove, add the remaining ingredients and mix well and press start. Remove, set to cool and grind the mixture to a rough paste and serve hot."

Category	Recipe-	Ingredients:	Weight 1	Weight 2
IB28	MUTTON LEVER CURRY	Mutton lever	2 cup	2½ cup
		Tomato (Chopped)	1 cup	1 cup
		Red chili powder	1½ tsp	2 tsp
		Onions (Chopped)	1 cup	1 cup
		Black Pepper Powder	¼ tsp	½ tsp
		Turmeric Powder	¼ tsp	¼ tsp
		Cinnamon	2	2
		Coriander seeds	1½ tsp	2 tsp
		Cumin seeds	¾ tsp	1 tsp
		Cloves	3	4
		Green Cardamoms	4	5
		Ginger and Garlic Paste.	1½ tsp	2 tsp
		Curry Leaves	few	few
		Oil as required		
		Salt to taste		
		Coriander Leaves for garnish		

Method of Preparation:

"Step 1: Take a microwave oven safe bowl, add all ingredients other than mutton, tomato, coriander leaves, mix well and select category, enter weight, press start.

Step 2: When the oven beeps, remove, add the remaining ingredients other than coriander leaves, mix well and press start. Serve hot."

INDIA'S BEST RECIPES

Category	Recipe-	Ingredients:		
IB29	CHANA MASALA	Chickpeas, Soaked	200 gms	250 gms
		Chopped Onion	1 cup	1 cup
		Chopped Tomato	¾ cup	¾ cup
		Mustard Seeds	½ tsp	½ tsp
		Curry Leaves	few	few
		Green Chili	1 tsp	1 tsp
		Bay Leafs	3	3
		Turmeric Powder	¼ tsp	¼ tsp
		Asafoetida	¼ tsp	¼ tsp
		Ginger-Garlic Paste	1 tsp	1 tsp
		Coriander Leaves For Garnishing		
		Salt As Required		
		Oil As Required		
		Water As Required		
		Oil As Required		
		For Roasting Masala:		
		Grated Coconut	¾ cup	¾ cup
		Cinnamon	3	3
		Fennel	1 tsp	1 tsp
		Cumin Seeds	1 tsp	1 tsp
		Coriander Seeds	1 tsp	1 tsp
		Red Chillies	2	2
		Cloves	few	few
		Cardamom	1	1
		Black Pepper	few	few
<p>Method of Preparation: "Step 1: Take a microwave oven safe bowl, add all ingredients other than chickpeas, tomato, coriander leaves, water, mix well and select category, enter weight, press start. Step 2: When the oven beeps, remove, add the remaining ingredients other than coriander leaves, mix well and press start. Remove and garnish with coriander leaves. Serve hot."</p>				

INDIA'S BEST RECIPES

Category	Recipe-	Ingredients:		
IB30	FISH CURRY	Fish - Washed & Sliced	200 gms	250 gms
		Coriander Leaves - Chopped	1 tbsp	1½ tbsp
		Tomatoes - Finely Chopped	2	2
		Garlic Cloves	5	6
		Green Chillies - Chopped	2	3
		Methi Seeds	1 tsp	1½ tsp
		Coriander Powder	1 tsp	1½ tsp
		Turmeric Powder	¼ tsp	½ tsp
		Salt To Taste		
		Oil As Required		

Method of Preparation:

"Marinate the fish in salt and turmeric powder for 15 minutes. Grind the coriander leaves, methi seeds, garlic and green chillies into a paste.

Step 1: Take a microwave oven safe bowl, add all the ingredients other than the fish and above paste. Mix well, select category, enter weight, press start.

Step 2: When the oven beeps, remove and add fish & coriander, methi seeds, green chili, garlic paste to the tadka and mix smoothly and press start. Remove and serve hot."

Category	Recipe-	Ingredients:		
Category	Recipe-	Ingredients:	Weight 1	Weight 2
IB31	TOMATO RASAM	Red Gram Dal	2½ tbsp	3 tbsp
		Tomatoes	4	5
		Garlic Paste	1½ tsp	2 tsp
		Garlic Grated	1½ tsp	2 tsp
		Ginger Chopped	¾ inch	1 inch
		Green Chillies Chopped	3	3
		Turmeric Powder	½ tsp	¾ tsp
		Mustard Seeds	1 tsp	1½ tsp
		Cumin Seeds	1 tsp	1½ tsp
		Dried Red Chillies	4	4
		Hing	a pinch	a pinch
		Curry Leaves	few	few
		Pepper Powder	1½ tsp	2 tsp
		Oil	2 tbsp	2 tbsp
		Salt To Taste		
		Water		
		Coriander Leaves For Garnish		

Method of Preparation:

"Step 1: In a microwave oven safe bowl, add all ingredients other than tomatoes, water, coriander, mix well. Place in the microwave, select category, enter weight, press start.

Step 2: After the beep, remove & add remaining ingredients other than coriander leaves, mix well and press start. Remove and garnished with coriander leaves. Serve hot"

INDIA'S BEST RECIPES

Category	Recipe-	Ingredients:		
IB32	PANEER MASALA	paneer (cut into cubes)	200 gms	250 gms
		tomatoes (chopped)	100 gms	1 cup
		oil	1 tbsp	1½ tbsp
		green chilli	4	4
		cumin seeds	1 tsp	1 tsp
		garlic ginger paste	1 tsp	1 tsp
		cloves	4	4
		turmeric powder	½ tsp	¾ tsp
		red chilli powder	2 tsp	2 tsp
		pepper powder	1 tsp	1 tsp
		cardamom powder	1 tsp	1 tsp
		salt to taste		
		water as required		
		coriander leaves for garnish		

Method of Preparation:

"Step 1: Take a microwave oven safe bowl, add all ingredients other than paneer, water and coriander leaves. Mix well, select category, enter weight, press start.

Step 2: When the oven beeps, remove and add paneer and water and mix well and press start. Remove, garnish with coriander and serve."

Category	Recipe-	Ingredients:	Weight 1	Weight 2
IB33	LEAFY VEGETABLE	Spinach Leaves, Washed & Chopped	1½ cup	2 cup
		Mustard Greens, Washed & Chopped	1½ cup	2 cup
		Cumin Seeds	½ tsp	1 tsp
		Green Chilli (Minced)	½ tsp	1 tsp
		Ginger Paste	½ tsp	1 tsp
		Garlic Paste	½ tsp	1 tsp
		Turmeric Powder	¼ tsp	½ tsp
		Red Chilli Powder	1 tsp	1½ tsp
		Hing A Pinch		
		Oil As Required		
		Salt To Taste		

Method of Preparation:

"Step 1: Take a microwave oven safe bowl, add all ingredients other than spinach leaves and mustard greens. Mix well, select category, enter weight, press start.

Step 2: When the oven beeps, remove and add the remaining ingredients, mix well. Cover the bowl with lid and place it in the microwave oven and press start. Serve hot."

INDIA'S BEST RECIPES

Category	Recipe-	Ingredients:		
IB34	TOMATO CURRY	Tomatoes (Chopped)	200 gms	250 gms
		Finely Chopped Onion	2	3
		Red Chilly Powder	1 tsp	1½ tsp
		Cumins	1 tsp	1 tsp
		Turmeric Powder	¼ tsp	½ tsp
		Garam Masala	1 tsp	1½ tsp
		Garlic Crushed	3	4
		Curry Leaves	few	few
		Oil As Required		
		Salt To Taste		

Method of Preparation:

"Step 1: Take a microwave oven safe bowl, add all ingredients other than tomato and garam masala. Mix well. select category, enter weight, press start.

Step 2: When the oven beeps, remove and add the remaining ingredients and mix well. Cover the bowl with lid and place it in the microwave oven and press start. Remove and serve hot."

Category	Recipe-	Ingredients:		
IB35	PRAWNS CURRY	Prawn - Shelled	200 gms	250 gms
		Onions Cut Into Small Pieces	2	3
		Garlic Paste	¼ tsp	½ tsp
		Ginger Paste	¼ tsp	½ tsp
		Chilli Powder	½ tsp	1 tsp
		Turmeric Powder	¼ tsp	½ tsp
		Mustard Seeds	¼ tsp	½ tsp
		Oil	½ tbsp	1 tbsp
		Salt To Taste		

Method of Preparation:

"Step 1: Take a microwave oven safe bowl, add all ingredients other than the prawns. Mix well, select category, enter weight, press start.

Step 2: When the oven beeps, remove and add the prawns and mix well. Place the bowl in the microwave oven and press start. Remove, and serve."

INDIA'S BEST RECIPES

Category	Recipe-	Ingredients:		
IB36	PALAK PANEER	Paneer	200 gms	250 gms
		Palak Paste	2 cup	3 cup
		Onion Paste	1 cup	2 cup
		Black Pepper Powder	½ tsp	½ tsp
		Ginger-Garlic Paste	1 tsp	1 tsp
		Green Chilli Paste	1 tsp	1 tsp
		Bay Leaves	2	3
		Cumin Seeds	1 tsp	1 tsp
		Garam Masala Powder	1 tsp	1 tsp
		Butter As Required		
		Salt To Taste		

Method of Preparation:

"Step 1: Take a microwave oven safe bowl, add all ingredients other than paneer, spinach paste, and salt. Mix well, select category, enter weight, press start.

Step 2: When the oven beeps, remove and add the remaining ingredients, mix well and press start. Serve hot."

Category	Recipe-	Ingredients:		
IB37	BHENDI FRY	Lady Finger (Okra / Bhendi)	200 gms	250 gms
		Gram Flour	½ cup	1 cup
		Sliced Onion	½ cup	1 cup
		Sliced Green Chilli	2	3
		Coriander Powder	½ tsp	1 tsp
		Red Chilli Powder	1 tsp	1½ tsp
		Garam Masala Powder	1 tsp	1½ tsp
		Cumin Seeds	½ tsp	1 tsp
		Turmeric Powder	¼ tsp	¼ tsp
		Oil As Required		
		Salt To Taste		

Method of Preparation:

Step 1: Take a microwave oven safe bowl, add all ingredients other than lady finger. Mix well, select category, enter weight, press start. Step 2: When the oven beeps, remove and add lady fingers, mix well and press start. Remove and serve hot.

INDIA'S BEST RECIPES

Category	Recipe-	Ingredients:	Weight 1	Weight 2
IB38	ALOO MATAR	Potatoes	1½ cup	2 cup
		Green Peas	1 cup	1½ cup
		Curd	1 cup	1½ cup
		Green Chillies	2	2
		Turmeric Powder	¼ tsp	¼ tsp
		Onion	1	2
		Tomatoes Puree	1 cup	1½ cup
		Ginger	½ tsp	½ tsp
		Coriander Powder	½ tsp	½ tsp
		Red Chilli Powder	1 tsp	1 tsp
		Garam Masala	1 tsp	1 tsp
		Oil As Required		
		Salt To Taste		
		Coriander Leaves For Garnish		

Method of Preparation:

"Step 1: Take a microwave oven safe bowl, add all ingredients other than tomato puree, salt, green peas, coriander leaves and curd. Mix well, select category, enter weight, press start.

Step 2: When the oven beeps, remove and add all remaining ingredients other than coriander leaves, mix well and press start. Remove, garnish with coriander leaves and serve."

Category	Recipe-	Ingredients:	Weight 1	Weight 2
IB39	PLAIN PALAK CURRY	Palak (Spinach) Finely Chopped	2 cup	2½ cup
		Red Chilly Powder	1 tsp	1 tsp
		Moong Dal	¼ cup	½ cup
		Garam Masala	1 tsp	1 tsp
		Turmeric Powder	¼ tsp	¼ tsp
		Garlic Paste	¼ tsp	¼ tsp
		Ginger Paste	¼ tsp	¼ tsp
		Oil As Required		
		Salt To Taste		

Method of Preparation:

"Step 1: Take a microwave oven safe bowl, add all ingredients other than palak and salt. Mix well, select category, enter weight, press start.

Step 2: When the oven beeps, remove and add the remaining ingredients, mix well and press start. Remove and serve hot."

INDIA'S BEST RECIPES

Category	Recipe-	Ingredients:	Weight 1	Weight 2
IB40	KADAI PANEER	Paneer	1½ cup	2 cup
		Tomatoes Chopped	¾ cup	1 cup
		Capsicums	¾ cup	1 cup
		Onions Cubed	1½ cup	2 cup
		Ginger Garlic Paste	1½ tsp	2 tsp
		Turmeric Powder	¼ tsp	½ tsp
		Coriander Seeds	¾ tsp	1 tsp
		Red Chillies	few	few
		Garam Masala	1½ tsp	2 tsp
		Kasoori Methi	¾ tsp	1 tsp
		Coriander Leaves Chopped	2½ tbsp	3 tbsp
		Cream	2½ tbsp	3 tbsp
		Salt To Taste		
		Oil As Needed		
<p>Method of Preparation: "Step 1: Take a microwave oven safe bowl, Add all ingredients other than paneer, capsicum, tomato, coriander leaves, creame and mix well and select category, enter weight, press start. Step 2: When the oven beeps, remove and add all remaining ingredients, mix well and press start. Serve hot."</p>				

INTERNATIONAL RECIPES

Category	Recipe-	Ingredients:	Weight 1	Weight 2
IN1	SPANISH RICE	Rice (Boiled)	1½ cup	2 cup
		Tomato (Chopped)	1½ cup	2 cup
		Tomato Puree	¾ cup	1 cup
		Onion (Chopped)	½ cup	½ cup
		Butter	1 tbsp	2 tbsp
		Pepper	½ tsp	½ tsp
		Salt To Taste		

Method of Preparation:

"Step 1: Take a microwave oven safe bowl; add butter, onion, tomato, tomato puree, salt and pepper stir and select category, enter weight, press start.

Step 2: When the oven beeps, remove and add boiled rice, mix well and press start. Serve hot."

Category	Recipe-	Ingredients:		
IN2	TOFU (THAI)	Tofu (Cut In To Cubes)	150 gram	200 gr
		Chopped Onion	½ cup	½ cup
		Sesame Oil	1 tsp	1½ tsp
		Olive Oil	1 tsp	1½ tsp
		Soya Sauce	2 tsp	2 tsp
		Grated Ginger	1 tsp	1 tsp
		Chunky Peanut Butter	¼ cup	¼ cup
		Flaked Coconut	1½ tbsp	2 tbsp
		Sesame Seeds	1 tbsp	1½ tbsp

Method of Preparation:

"Step 1: In a MWO safe bowl add olive oil, sesame oil, onion, tofu, Soya sauce, peanuts butter, ginger, stir carefully without breaking the tofu, until well incorporated, and select category, enter weight, press start.

Step 2: When the oven beeps, remove the bowl from microwave oven and add flaked coconut and sprinkle sesame seeds. Cover the bowl with lid and press start. Serve hot."

INTERNATIONAL RECIPES

Category	Recipe-	Ingredients:	Weight 1	Weight 2
IN3	ITALIAN VEGGIE PIZZA	Pizza Base	1	1
		Butter	1 tbsp	1 tbsp
		Chopped Cabbage	¼ cup	½ cup
		Chopped Green Pepper	¼ cup	½ cup
		Chopped Mushrooms	¼ cup	½ cup
		Sweat Peas	¼ cup	½ cup
		Chopped Carrot	¼ cup	½ cup
		Tomato Ketch Up		2 tbsp
		Red Chili Powder	1 tsp	1 tsp
		Grated Cheese	½ cup	½ cup
		Salt To Taste		

Method of Preparation:

Step 1: Take a pizza base, apply butter, ketchup, some grated cheese on the pizza base and arrange all vegetables on it, pour the remaining grated cheese on the top of vegetables. Put pizza base on the grill mesh rack, place it in the oven and select category, enter weight, press start. Cut in to pieces and Serve hot.

Category	Recipe-	Ingredients:	Weight 1	Weight 2
IN4	MOYETTES (MEXICAN)	Mushrooms (Quartered)	¾ cup	1 cup
		Tomatoes (Chopped)	¾ cup	1 cup
		Crushed Garlic	1 clove	1 clove
		Chopped Green Chillies	1 tsp	1 tsp
		Onions Chopped	¾ cup	1 cup
		Red Chilly Powder	½ tsp	½ tsp
		Roasted Cumin Seeds Powder	1 tsp	1 tsp
		Sugar	1 tsp	2 tsp
		Butter	2 tbsp	3 tbsp
		Salt To Taste	½ cup	½ cup
		Bread Buns	4	4
		Grated Cheese		
		(Option For The Topping)		
		Shredded Cabbage		
		Grated Carrot		
		Chopped Spring Onions		

Method of Preparation:

"Take a mixing bowl, add 2 tbsp butter, onion, mushrooms, tomato, garlic, green chilly, chilly powder. Cumin's seed powder, sugar, salt, mix all ingredients.

Step 1: Cut off the tops from the buns, scoop out the centers, and fill the centers with some mixed vegetable and top with some grated cheese; apply 1 table spoon butter lightly on to all buns. Arrange all buns in on a crusty plate and put it on grill rack and sselect category, enter weight, press start.Take out moyettes from oven and top with cabbage, carrot, spring onions and serve."

INTERNATIONAL RECIPES

Category	Recipe-	Ingredients:	Weight 1	Weight 2
IN5	SPANISH FLAN	White Sugar	1½ cup	2 cup
		Eggs	5	6
		Sweetened Condensed Milk	¾ cup	1 cup
		Evaporated Milk (Thick)	¾ cup	1 cup
		Vanilla Extract	¼ tsp	¼ tsp

Method of Preparation:

"Step 1: Take sugar in a microwave oven safe bowl, add little water and select category, enter weight, press start to melt sugar.

Step 2: When the oven beeps, remove and press start to preheat the oven.

Step 3:-After the oven beeps, add beaten eggs; condensed milk, evaporated milk and vanilla extract, in to melted sugar and blend all ingredients until smooth. Pour the egg mixture in a Baking dish. Set the baking dish in a pre-heated oven and press start. Let it cool completely and serve."

Category	Recipe-	Ingredients:	Weight 1	Weight 2
IN6	SPANISH BAKED FISH	Fish	200 g	300 g
		Butter	1½ tbsp	2 tbsp
		Sour cream	½ cup	½ cup
		Bread crumbs	1 cup	1 cup
		Grated cheese	¼ cup	¼ cup
		Parsley (for garnish)		

Method of Preparation:

"Marinate fish with butter and sour cream for 15 minutes.

Step 1: Put the marinade fish in a microwave oven safe bowl and cover with lid then select category, enter weight, press start.

Step 2: When the oven beeps, press start to preheat the oven.

Step 3: Sprinkle with bread-crumbs and grated cheese over fish and put in on high rack and press start. Garnish with parsley. Serve hot."

INTERNATIONAL RECIPES

Category	Recipe-	Ingredients:	Weight 1	Weight 2
IN7	LASAGNA (ITALIAN)	Butter (Melted)	1½ tbsp	2 tbsp
		Flour	1½ tbsp	2 tbsp
		Milk	¾ cup	1 cup
		Garlic	½ tsp	½ tsp
		Chicken Broth	½ cup	½ cup
		Cheese	¾ cup	1 cup
		Onions Chopped	2	2
		Salt To Taste		
		Basil (Dried)	½ tsp	½ tsp
		Oregano Leaves (Dried)	½ tsp	½ tsp
		Pepper	½ tsp	½ tsp
		Lasagna Layers (Cooked)	4	4
		Chicken Chunks	¾ cup	1 cup
		Spinach	50 gms	50 gms
		*Béchamel Sauce; *	1 Cup	1½ Cup
		*Béchamel Sauce; * 1½ Cup		
		Flour	10 gram	10 gram
		Butter	10 gram	10 gram
		Milk	100 gram	100 gram
		Bay Leave	3	3
		Nutmeg	a pinch	a pinch
		Salt	a pinch	a pinch
		A Pinch Of Block Pepper	few	few

Method of Preparation:

"Step 1: Take a microwave oven safe bowl, add butter, onions, spinach, flour, salt, milk, broth, cheese, basil, oregano, pepper, chicken chunks and stir. Select category, enter weight, press start. When the oven beeps, remove and keep it aside to cool. Spread the béchamel sauce mixture in the bottom of the baking dish and spread the cheese. Arrange Lasagna layer over the sauce. Pour some chicken, spinach mixture, cheese, over the lasagna layer and spread remaining sauce evenly over lasagna layers and sprinkle with cheese.

Step 2: Press start to preheat oven.

Step 3:- When the oven beeps, insert baking dish in preheated oven and press start to bake."

INTERNATIONAL RECIPES

Category	Recipe-	Ingredients:	Weight 1	Weight 2
IN8	CRUSTLESS MI-CROWAVE QUICHE (FRENCH)	Eggs	2	3
		Light Cream	½ cup	¾ cup
		Nutmeg	a pinch	a pinch
		Pepper	½ tsp	½ tsp
		Spinach (Broccoli, Optional)	200 gr	300 gr
		Bacon (Cooked & Crumbled)	2 slices	2 slices
		Cheese	½ cup	½ cup
		Chopped Onions	¼ cup	¼ cup
		Salt To Taste		
<p>Method of Preparation: "Step 1: Mix all ingredients together and pour it into lightly greased oven safe bowl, select category, enter weight, press start. Step 2: When the oven beeps, press start to preheat oven. Step 3: After the beep, remove and put quiche on the grill rack and press start to bake."</p>				

Category	Recipe-	Ingredients:	Weight 1	Weight 2
IN9	SPANISH COOKIES	All- Purpose Flour	1½ Cup	2 cups
		Melted Butter	¾ cup	1 cup
		White Sugar	½ cup	¾ cup
		Anise Extract	¼ tsp	¼ tsp
		Grounded Cinnamon	1/8 tsp	1/8 tsp
		Blanched Almonds	18	24
<p>Method of Preparation: "Combine flour, sugar, and cinnamon together, and add melted butter until all is mixed well. Stir in the anise extract and knead for 15 minutes. Roll it into 1 inch balls and place it on the ungreased baking dish. Place blanched almonds on the top of each cookie and push it down slightly. Step 1: Select category, enter weight, press start to pre heat the oven. Step 2: When the oven beeps, Put the baking dish in preheated oven and press start to bake. Let cookies cool on baking dish for 10 minutes."</p>				

INTERNATIONAL RECIPES

Category	Recipe-	Ingredients:	Weight 1	Weight 2
IN10	THAI CHIKEN BALLS	Ground Chicken	200 g	300 g
		Bread Crumbs	1 cup	1½ cup
		Green Onions (Sliced)	½ cup	¾ cup
		Ground Coriander Seeds	few	few
		Chopped Fresh Cilantro	2 tbsp	2 tbsp
		Sweat Chili Sauce	2 tbsp	2 tbsp
		Fresh Lemon Juice	1 tsp	1 tsp
		Oil	2 tbsp	2 tbsp

Method of Preparation:

"In a MWO safe bowl mix together the chicken and bread crumbs, onion, coriander, Cilantros, chili sauce, lemon juice. Mix well. Using damp hands, form the mixture into evenly shaped balls that are either small enough to eat as mini balls or large enough to use it as a filling for burgers. Apply oil lightly to all the balls from outside . Arrange the balls on the crusty plate.

Step 1: Select category, enter weight, press start to pre-heat the oven.

Step 2: When the oven beeps, place the crusty plate in on grill rack and press start to bake the balls. Serve hot."

Category	Recipe-	Ingredients:	Weight 1	Weight 2
IN11	ENGLISH MUFFINS. (ENGLAND)	Warm Milk	½ liter	¾ liter
		Desolved Yeast	¼ cup	½ cup
		Grounded Sugar	1 tsp	1 tsp
		Flour (Enough To Make Stiff Batter)		
		Butter	½ cup	½ cup
		Soda (Dissolved In A Little Water)	1 tsp	1 tsp

Method of Preparation:

"Take a mixing bowl, add warm milk, yeast, sugar and enough flour to make a stiff batter. Let it stand for 1 hour to rise. Add melted butter and soda. Take enough flour to make a very stiff batter and let it rise for one hour. Fill the batter into well greased muffin rings or plate.

Step 1: Select category, enter weight, press start to preheat the oven.

Step 2: Put the muffin rings in pre-heated oven and press start to bake."

INTERNATIONAL RECIPES

Category	Recipe-	Ingredients:		
IN12	CHOCOLATE-BREAD PUDDING (ENGLAND)	Bread Crumbs	200 gr	300 gr
		Milk	½ liter	½ liter
		Butter	40 gram	50 gram
		Sugar	80 gram	100 gram
		Chocolate	50 gram	70 gram
		Eggs (Yolk & White Suppurate)	3	4
		Vanilla Essence	¼ tsp	¼ tsp
<p>Method of Preparation: "Soak the bread crumbs in milk and dry them, add butter mixed sugar, chocolate, and egg yolks, vanilla essence and egg white. Mixes all the ingredients well and set it aside. Step 1: Select category, enter weight, press start to preheat the oven. Pour the pudding in lightly greased baking dish. Step 2: place the baking dish on the grill rack and press start. "</p>				

Category	Recipe-	Ingredients:	Weight 1	Weight 2
IN13	APPLE SOUFFLE (FRENCH)	Apples, Peeled & Chopped	2 big size	3 big size
		Eggs (Divide In To Yolks & White)	2	2
		Butter	2 tbsp	2 tbsp
		Sugar	2 tbsp	2 tbsp
		Lime Juice	1 tsp	1 tsp
		Lemon Rind	¼ tsp	¼ tsp
<p>Method of Preparation: "In a bowl, add apples and butter. Mash well. Take another mixing bowl, beat the yolk of eggs with sugar, apple mash, lime juice, rind of lemon, mix well and add the egg white to it. Mix properly. Step 1: Select category enter weight, press start to preheat the oven. Step 2: Pour the apple mixture in a buttered pudding dish and press start to bake."</p>				

INTERNATIONAL RECIPES

Category	Recipe-	Ingredients:	Weight 1	Weight 2
IN14	MEXICAN VEG - KEBABS	Green Peppers (Cut In To Large Slices)	¾ cup	1 cup
		Yellow Peppers (Cut In To Large Slices)	¾ cup	1 cup
		Baby Corns (Cut In To Two)	¾ cup	1 cup
		Cottage Cheese (Paneer) Large Slices	¾ cup	1 cup
		Mushrooms	¾ cup	1 cup
		White Onions (Cut In To Large Slices)	¾ cup	1 cup
		Chilly Powder	1 tsp	2 tsp
		Cocoa Powder	1 tsp	2 tsp
		Crushed Garlic	2 cloves	4 cloves
		Oregano	½ tsp	½ tsp
		Fresh Curd	1 tbsp	2 tbsp
		Sour Cream For Serve	¾ cup	1 cup
		Spring Onions (Chopped) For Garnish	½ cup	½ cup
		Salt To Taste		
		Sepper To Taste		
<p>Method of Preparation: "Take a mixing bowl; add green and yellow peppers, baby corns, cottage cheese, mushrooms, white onions, chilly powder, cocoa powder, garlic, oregano, curds, salt and pepper. Stir all ingredients and allow to marinade for 4 hours. Arrange one piece each of all vegetables on the skewer. Step 1: Select category, enter weight, press start to pre heat the oven. Step 2: When the oven beeps, insert skewer properly in oven and press start. Serve hot with sour cream and spring onions."</p>				

INTERNATIONAL RECIPES

Category	Recipe-	Ingredients:	Weight 1	Weight 2
IN15	CARROT CAKE (FRENCH)	Grated Carrots	1½ cup	2 cup
		Flour	¾ cup	1 cup
		Sugar	¾ cup	1 cup
		Cinnamon	½ tsp	½ tsp
		Nutmeg	½ tsp	½ tsp
		Baking Powder	1 tsp	1 tsp
		Baking Soda	½ tsp	½ tsp
		Egg	1	1
		Oil	½ cup	½ cup
		Vanilla Extract	¼ tsp	¼ tsp
		Chopped Walnuts	¼ cup	¼ cup
<p>Method of Preparation: "Take a mixing bowl, add flour sugar, cinnamon, nutmeg, baking soda, baking powder. Mix well. Now add oil, egg, carrots, vanilla and walnuts and stir. Step 1: Select category, enter weight, press start to pre heat the oven. Step 2: When the oven beeps, Pour the mixture in to Lightly greased baking dish put in preheated oven and press start to bake."</p>				

Category	Recipe-	Ingredients:	Weight 1	Weight 2
IN16	APPLE CAKE (FRENCH)	Finely Chopped Apples	1½ cup	2 cups
		Sugar	1 cup	1½ cup
		Egg (Beaten)	1	1
		Flour	½ cup	1 cup
		Cinnamon	½ tsp	½ tsp
		Baking Powder	½ tsp	½ tsp
		Vanilla Extract	¼ tsp	¼ tsp
		Raisins (Kismis)	2 tbsp	2 tbsp
		Nuts (Chopped)	2 tbsp	2 tbsp
<p>Method of Preparation: "Place apples in large mixing bowl, add sugar, stir and let stand for ½ hour. Add egg, flour, cinnamon, baking powder, nuts, and raisins and blend well. Step 1: Select category, enter weight, press start to preheat the oven. Step 2: When the oven beeps, pour the mixture in to lightly greased baking dish and press start to bake. Serve with powdered sugar sprinkled over cake."</p>				

INTERNATIONAL RECIPES

Category	Recipe-	Ingredients:		
IN17	CINNAMON HONEY WINGS (ITALIAN)	Chicken Wings	200 gr	300 gr
		Garlic (Chopped)	3 cloves	4 cloves
		Olive Oil	1½ tbsp	2 tbsp
		Soy Sauce	1½ tbsp	2 tbsp
		Rice Vinegar	¼ cup	¼ cup
		Honey	¼ cup	¼ cup
		Cinnamon (Ground)	¼ tsp	¼ tsp
		Thyme	1 tsp	1 tsp
		Ginger (Ground)	½ tsp	½ tsp
		Mustard (Dry)	½ tsp	½ tsp

Method of Preparation:

"Take a mixing bowl; add oil, garlic, ginger, mustard, thyme, cinnamon, honey, vinegar, soy sauce, chicken wings. Mix well and set it aside for 2 hours to marinade.

Step 1: Select category, enter weight, press start to pre heat the oven.

Step 2: When the oven beeps, Arrange the chicken wings on lightly greased baking dish and press start. Serve hot."

Category	Recipe-	Ingredients:		
IN18	BARBECUED ORANGE CHICKEN (ENGLAND)	Chicken	200 gr	300 gr
		Onions (Chopped)	1½	2
		Tomato (Cut In To Wedges)	¾ cup	1 cup
		Vinegar	1 tbsp	1 tbsp
		Pepper	1/8 tsp	1/8 tsp
		Salt To Taste		
		Oil To Taste		
		Orange Slices (With Out Rind) For Garnish		
		Bbq Sauce:		
		Oil	1 tbsp	1 tbsp
		Orange Juice	2 tbsp	2 tbsp
		Vinegar	1 tbsp	1 tbsp
		Tomato Paste	2 tbsp	2 tbsp
		Orange Zest (Removed With Grater)	1 tbsp	1 tbsp

Method of Preparation:

"Marinate the chicken with all BBQ ingredients for 30 minutes.

Step 1: Take a microwave oven safe bowl, add all ingredients other than marinated chicken, orange slices and mix well. Select category , enter weight, press start. Step 2: When the oven beeps, remove and add all remaining ingredients other than orange slices, mix well and arrange into a lightly greased baking dish and press start. Serve chicken with orange slices on the side."

INTERNATIONAL RECIPES

Category	Recipe-	Ingredients:	Weight 1	Weight 2
IN19	MACARONI AND CHEESE (FRENCH)	Butter	¼ cup	½ cup
		Onion, Finely Chopped	¾ cup	1 cup
		Flour	2 tbsp	3 tbsp
		Milk	1 cup	1½ cup
		Grated Tasty Cheese	½ cup	½ cup
		Cooked Macaroni (Drained Well)	2 cup	2½ cup
		Paprika	1 tsp	1 tsp

Method of Preparation:

"Step 1: Take onion, flour, milk, mix well and blend all smoothly. Pour the mixture into a microwave oven safe bowl and select category, enter weight, press start.

Step 2: When the oven beeps, add butter, macaroni, cheese and sprinkle with paprika, stir and press start.

Step 3: After the beep, remove and collect the mixture into another Grill safe utensil and top it with extra grated cheese. Put it on grill rack and Press start."

Category	Recipe-	Ingredients:	Weight 1	Weight 2
IN20	PIQUANT CHICKEN WINGS (CHINESE)	Chicken Lollipops	200 gms	300 g
		Orange Juice	½ cup	1 cup
		Corn Flour	2 tbsp	2 tbsp
		Crushed Black Pepper Corns	½ tsp	1 tsp
		Crushed Red Chilies	1 tsp	2 tsp
		Honey	2 tbsp	3 tbsp
		Lemon Juice	1 tbsp	2 tbsp
		Salt To Taste		

Method of Preparation:

"Place the chicken lollipops in a bowl and add orange juice and salt. Marinate the chicken for 30 minutes.

Step 1: Select category, enter weight, press start to cook the marinade chicken.

Step 2: When the oven beeps, remove and add crushed peppercorns, crushed red chilies, honey and press start.

Step 3: After the beep, remove and mix corn flour in a half cup of water. Add the flour mix and lemon juice onto chicken lollipops. Stir and press start. Serve hot."

INTERNATIONAL RECIPES

Category	Recipe-	Ingredients:	Weight 1	Weight 2
IN21	PRAWN CURRY (THAI)	French Beans	¾ cup	1 cup
		Prawns	1½ cup	2 cup
		Mushrooms (Sliced)	¾ cup	1 cup
		Red Pepper (Cut In To Slices)	¾ cup	1 cup
		Thai Red Curry Paste	2 tbsp	2 tbsp
		Chicken Stock		
		Thai Fish Sauce	2 tbsp	2 tbsp
		Coconut Milk	¾ cup	1 cup
		Basil	1 tsp	1 tsp
		Coriander	1 tbsp	2 tbsp
		Lime Juice	1 tsp	1 tsp
		Olive Oil	2 tbsp	2 tbsp
		Basmati Rice (Cooked)	2 cup	2 cup
		Thai Red Curry Paste		
		5 Red Chilies (Soaked In Warm Water/Drained)		
		¼ Cup Chopped Onions		
		2 Peeled Garlic Cloves		
		½ Tbsp Grated Ginger		
		1 Stalk Lemon Grass		
		1 Stalk Coriander		
		1 Tbsp Coriander Seeds (Dania)		
		½ Tbsp White Pepper		
		½ Tsp Salt		
Method of Preparation:				
"Step 1: Take a MWO safe bowl, add oil, beans, red peppers, mushrooms and thai red curry paste. Mix well and select category, enter weight, press start.				
Step 2: When the oven beeps, remove and add prawn, chicken stock, fish sauces, basil, coriander, coconut milk, lime juice, stir and press start. Serve over basmati rice."				

INTERNATIONAL RECIPES

Category	Recipe-	Ingredients:	Weight 1	Weight 2
IN22	FRITTATA (ITALIAN)	Eggs	3	4
		Red Capsicums	¼ cup	½ cup
		Yellow Capsicum	¼ cup	½ cup
		Zucchini	¼ cup	½ cup
		Fresh Basil Leaves	few	few
		Crushed Black Pepper	½ tsp	½ tsp
		Oil As Required		
		Salt To Taste		

Method of Preparation:

"Beat the eggs in a bowl with salt & pepper. Set it aside.

Step 1: Take a MWO safe bowl add oil, red capsicum, yellow capsicum, zucchini, basil, crushed black pepper, stir and select category, enter weight, press start.

Step 2: When the oven beeps, remove and pour the egg mixture in it, cover the bowl with lid, mix well and press start.

Step 3: When the oven beeps, remove and turn over and press start. Serve hot. "

Category	Recipe-	Ingredients:	Weight 1	Weight 2
IN23	MEXICAN RICE	Oil	2 tbsp	2 tbsp
		Rice	1½ cup	2 cup
		Salt	1 tsp	1 tsp
		Cumin	½ tsp	½ tsp
		Chopped Tomato	¾ cup	1 cup
		Tomato Puree	½ cup	½ cup
		Chicken Broth	2 cup	3 cup
		Onion (Chopped)	1 cup	1 cup

Method of Preparation:

"Step 1: In a microwave oven safe bowl add oil, cumin's, onions, salt, rice, mix well and select category, enter weight, press start.

Step 2: When the oven beeps, now add chicken broth and tomato sauce stir, and press start.

Step 3: After the beep, remove, mix well and cover the bowl with lid and press start. Let it stand for 5 minutes & serve."

INTERNATIONAL RECIPES

Category	Recipe-	Ingredients:		
IN24	FISH A LA MARSEILLES (FRENCH)	Fish (Use Two Kinds Of Fish Cut In To Slices)	200 g	300 g
		Onion (Sliced)	¾ cup	1 cup
		Tomato (Chopped)	¾ cup	1 cup
		Parsley (Minced)	¼ cup	¼ cup
		Thyme (Minced)	¼ cup	¼ cup
		Bay Leaves (Minced)	2	3
		Pepper	½ tsp	½ tsp
		Chilly Powder (Optional)	1 tsp	1 tsp
		Garlic (Minced)	2 cloves	3 cloves
		Butter	¼ cup	¼ cup
		Juice Of Lemon	1 tsp	2 tsp
		Water	1½ cup	2 cup
		Sherry (White Wine)	1 cup	1 cup
		Sugar		
		Salt To Taste		

Method of Preparation:

"Season the fish slices with salt, garlic, parsley, thyme, bay leaves and pepper. Set it aside.

Step 1: Take a oven safe bowl; add butter, onion, tomato, chilly powder, juice of lemon and seasoned fish slices.

Mix all ingredients well, then select category, enter weight, prsee start.

Step 2: When the oven beeps, remove and add water, sherry, sugar pour over the fish. Mix slowly and press start.

Serve with toast."

Category	Recipe-	Ingredients:	Weight 1	Weight 2
IN25	SCRAMBLED EGGS (ENGLAND)	Eggs	4	5
		Mozzarella Cheese	¼ cup	¼ cup
		Butter (Melted)	¼ cup	¼ cup
		Milk	2 tbsp	3 tbsp
		Onion (Chopped)	1½ cup	2 cup
		Mushrooms (Chopped)	1½ cup	2 cup

Method of Preparation:

"Step 1: Take a microwave oven safe bowl; add butter, onion, mushrooms stir and select category, enter weight, press start.

Step 2: When the oven beeps, remove and break eggs in to a bowl. Whip until fully beaten. Add milk, mix well and press start. Place cheese slice on the top of the eggs, cover with lid and stand until cheese melts. Serve hot."

INTERNATIONAL RECIPES

Category	Recipe-	Ingredients:	Weight 1	Weight 2
IN26	CHICKEN HUNTER'S STYLE {ITALIAN}	Chicken	200 g	300 g
		Butter	1½ tbsp	2 tbsp
		Oil	1 tbsp	1½ tbsp
		Finely Chopped Onion	1 cup	1½ cup
		Green Peppers Chopped	½ tsp	½ tsp
		Garlic Cloves Minced	2	2
		Basil	½ tsp	½ tsp
		Salt	1 tsp	1 tsp
		Pepper	½ tsp	½ tsp
		Stewed Tomato (Undrained)	¾ cup	1 cup
		Tomato Juice Or Chicken Broth	½ cup	½ cup
		Sliced Mushrooms For Garnish.		
<p>Method of Preparation: "Step 1: Take a microwave safe bowl; add butter, oil, onion, green pepper, garlic, basil, salt, pepper. Stir well and select category, enter weight, press start. Step 2: When the oven beeps, remove and add chicken stir and press start. Step 3: When the oven beeps, remove and add tomato, tomato juice or chicken broth or water, stir and press start. Garnish with mushroom slices, If desired. Serve hot."</p>				

Category	Recipe-	Ingredients:	Weight 1	Weight 2
IN27	PASTA CHICKEN (ITALIAN)	Chicken Breast (Diced)	200 g	300 g
		Broccolis (Diced)	¼	½
		Garlic Cloves (Minced)	4	5
		Basil	¼ tbsp	¼ tbsp
		Oregano	¼ tbsp	¼ tbsp
		Carrots (Cut In To Small Pieces)	½ cup	½ cup
		Ripe Tomatoes	½ cup	½ cup
		Shell Pasta	1 cup	1½ cup
		Olive Oil	2 tbsp	2 tbsp
		Grated Cheese (For Taste & Garnish)		
<p>Method of Preparation: "Step 1: Take a MWO safe bowl; add water, pasta, broccoli, mix well and select category, enter weight, press start. Keep it aside. Step 2: When the oven beeps, take another MWO safe bowl, add oil, tomatoes, garlic, basil, oregano, and chicken mix all ingredients and press start. Step 3: When the oven beeps, remove and drain the boiled pasta and broccoli add in to cooked chicken. Stir well and cover the bowl with lid and press start to cook. Garnish with grated cheese and serve."</p>				

INTERNATIONAL RECIPES

Category	Recipe-	Ingredients:	Weight 1	Weight 2
IN28	MOO GOO GAI PAN (CHINESE)	Chicken (Breast Halves, Skinned, And Sliced)	200 g	300 g
		Pepper	¼ tsp	1 tsp
		Garlic	2 cloves	3 cloves
		Water	¾ cup	1 cup
		Corn Starch	2 tbsp	3 tbsp
		Oil	2 tbsp	2 tbsp
		Sliced Mushrooms	½ cup	½ cup
		Chopped Cabbage	½ cup	¾ cup
		Sugar	2 tbsp	2 tbsp
		Soy Sauce	2 tbsp	2 tbsp
		Scallions (Chopped)	¾ cup	1 cup
		Salt To Taste		

Method of Preparation:

"In a bowl, toss chicken with salt and pepper, garlic and cornstarch mixture. Set it aside.

Step 1: Take an oven safe bowl add oil, mushrooms, cabbage, sugar Mix well and select category, enter weight, press start. Step 2: When the oven beeps, remove and add chicken, Soy sauce, scallions stir well and press start. Serve hot."

Category	Recipe-	Ingredients:	Weight 1	Weight 2
IN29	COUNTRY STYLE CHICK- EN STEW (ENGLAND)	Chicken (Cut In To Pieces)	200 g	300 g
		Potatoes (Cut In To Pieces)	¾ cup	1 cup
		Carrot (Cut In To Pieces)	½ cup	½ cup
		Onion, Cut In To Pieces	¾ cup	1 cup
		Tiny Pearl Onions (Peeled)	3	5
		French Beans (Cut In To Pieces)	½ cup	½ cup
		Cauliflower Florets	½ cup	½ cup
		Bay Leaves	3	3
		Springs Of Parsley	few	few
		Celery Stalk (Lightly Crushed)	1 inch	2 inch
		Dried Thyme	½ tsp	½ tsp
		Block Pepper Corns (Crushed)	3	3
		Oil	2 tbsp	2 tbsp
		Garlic (Crushed)	4 cloves	6 cloves
		Whole Wheat Flour	2 tbsp	2 tbsp
		Salt To Taste		
		Water As Required		

Method of Preparation:

"Step 1: Take oil in a oven safe bowl, add flour, chicken, garlic, stir and select category, enter weight, press start.

Step 2: When the oven beeps, remove and add potatoes, carrot, turnip, french beans, cauliflower, onions, bay leaf, parsley, celery, water, thyme, and pepper corns, salt. Stir all ingredients and press start. Serve hot."

INTERNATIONAL RECIPES

Category	Recipe-	Ingredients:		
IN30	CHICKEN CASSEROLE (ITALIAN)	Chicken (Cut In To Pieces)	200 gr	300 gr
		Baby Onions	¾ cup	1 cup
		Tomatoes	¾ cup	1 cup
		Tomato Paste	¾ cup	1 cup
		Marjoram	¼ tsp	¼ tsp
		Oregano	¼ tsp	¼ tsp
		Button Mushrooms	¾ cup	1 cup
		Block Olives	1 tsp	1 tsp
		Garlic	1 clove	1 clove
		Chopped Parsley	few	few
		Salt And Pepper To Taste		
		Water As Required		
		Oil As Required		
<p>Method of Preparation: "Step 1: Take a microwave oven safe bowl; add oil, garlic, onions, marjoram, oregano, chicken, block olives, stir well and select category, enter weight, press start. Step 2: When the oven beeps, remove and add tomatoes, tomato paste, mushrooms, water, parsley, salt & pepper. Stir and press star. Serve hot."</p>				

BREAKFAST/SNACKS

Category	Recipe-	Ingredients:	
BS1	SEMIYA PULIHORA	roasted vermicelli / semya	300 gms
		urad dal	1½ tsp
		chana dal	1½ tsp
		turmeric powder	¼ tsp
		green chillies	3
		oil	1 tbsp
		lemon	¾ tsp
		mustard seeds	¾ tsp
		cumin seeds	¾ tsp
		fenugreek seeds	¾ tsp
		broken dry chillies	3
		hing	a pinch
		curry leaves	few
		salt to taste	
Method of Preparation:			
"Step 1: Take a microwave oven safe bowl, add all ingredients other than roasted semya, lemon, hing, mix well and select category, enter weight, press start.			
Step 2: After the beep, remove and add all remaining ingredients, mix well and press start. serve hot."			

Category	Recipe-	Ingredients:	
BS2	VERMICELLI UPMA	vermicelli, roasted	2 cup
		onion, chopped	1½ cup
		curry leaves	few
		mustard seeds	½ tsp
		cumin	1 tsp
		urad dal	2 tbsp
		green chili, chopped	1 tsp
		red chili	2
		ginger	½ tsp
		salt as required	
		oil as required	
		water as required	
Method of Preparation:			
"Step 1: Take a microwave oven safe bowl, add all ingredients other than roasted vermicelli, water, mix well and select category, enter weight, press start.			
Step 2: After the beep, remove and add all remaining ingredients, mix well and press start. serve hot."			

BREAKFAST/SNACKS

Category	Recipe-	Ingredients:	
BS3	BREAD UPMA	Bread Slices (Cut Into Small Pieces)	250 gms
		Oil	1½ tbsp
		Mustard Seeds	1 tsp
		Jeera	1 tsp
		Curry Leaves	few
		Onion (Chopped)	1 cup
		Chopped Green Chillies	4 nos.
		Chopped Tomatoes	3 nos.
		Red Chilli Powder	
		Lemon Juice	
		Turmeric Powder	
		Salt to taste	
Method of Preparation: "Step 1: In a microwave oven safe bowl add all ingredients other than bread slices, tomatoes, lemon juice, mix well, Select category & weight and press start. Step 2: When the oven beeps, remove and add other remaining ingredients, mix well and press start. "			

Category	Recipe-	Ingredients:	
BS4	CHIVDA	Thin White Poha	2 cup
		Raw Peanuts	¾ cup
		Chana Dal	2 tbsp
		Cashew Nuts	½ cup
		Coconut Slices	½ cup
		Raisins	1 tbsp
		Curry Leaves	few
		Green Chili	2 tsp
		Turmeric Powder	¼ tsp
		Hing	a pinch
		Sugar	1 tsp
		Oil As Required	
		Salt To Taste	
Method of Preparation: "Step 1: Take a microwave oven safe bowl, add all ingredients other than poha, cashew nuts, raisins, mix well and select category, enter weight, press start. Step 2: After the beep, remove and add all remaining ingredients, mix well and press start. serve hot."			

BREAKFAST/SNACKS

Category	Recipe-	Ingredients:	
BS5	UGGANI	Puffed rice (murmura)	3 cup
		Besan (roasted)	2 tbsp
		Oil	1½ tbsp
		Mustard seeds (spluttered)	1 tsp
		Green chilli (chopped)	2 nos.
		Curry leaves	few
		Coriander leaves (chopped)	2 tbsp
		Onion (chopped)	2 nos.
		Tomato (chopped)	2 nos.
		Lemon juice (optional)	1 tbsp
		Red chilli powder	1 tsp
		Garam masala	1 tsp
		Turmeric powder	¼ tsp
		Salt to taste	
<p>Method of Preparation: "Step 1: Take a microwave oven safe bowl, add all ingredients other than puffed rice, tomato, lemon juice, mix well and select category, enter weight, press start. Step 2: After the beep, remove and add all remaining ingredients, mix well and press start. Serve hot."</p>			

Category	Recipe-	Ingredients:	
BS6	MUMPALLI ROAST	Mumpalli	250 gr
<p>Method of Preparation: "Step 1: In a microwave oven safe glass bowl, add mumpalli and select category, enter weight and press start. Step 2: When the oven beeps, remove and mix well and press start. Serve hot."</p>			

Category	Recipe-	Ingredients:	
BS7	TEA	Milk	4 cup
		Tea Powder	3 tsp
		Sugar To Taste	
		Water As Required	
<p>Method of Preparation: "Step 1: In a microwave oven safe bowl, add all ingredients other than sugar, mix well and select category, enter weight and press start. Step 2: When the oven beeps, remove and add sugar, mix well and press start. Serve hot."</p>			

BREAKFAST/SNACKS

Category	Recipe-	Ingredients:	
BS8	MASALA PEANUTS	Peanuts	250 gms
		Red Chilli Powder	1 tbsp
		Gram Flour (Besan)	1½ cup
		Rice Flour	1 tbsp
		Coriander Powder (Dhania)	1½ tsp
		Turmeric Powder	1 tsp
		Salt To Taste	2 tsp
		Water As Required	
<p>Method of Preparation: "Mix all ingredients in a mixing bowl and set aside for 20 minutes to marinate. Step 1: In a microwave oven safe glass bowl, add all marinated ingredients, Select category, enter weight, press start. Step 2: When the oven beeps, remove, stir well and press start. "</p>			

Category	Recipe-	Ingredients:	
BS9	KHANDVI	Besan	2 cup
		Butter Milk	4 cup
		Turmeric Powder	½ tsp
		Oil	¾ tbsp
		Sesame Seeds	2 tsp
		Mustard Seeds	¾ tsp
		Coconut Scraped	¾ tbsp
		Chopped Coriander	¾ tbsp
		Hing	a pinch
		Chopped Green Chillies	3
		Salt To Taste	
<p>Method of Preparation: "Step 1: Take butter milk in a microwave oven safe bowl, add besan, turmeric powder, oil, salt, sesame seeds, mustard, hing, coconut, coriander, green chillies & mix well to avoid lump formation. Place the bowl on the turn table in the microwave oven, select category, enter weight & press start. Step 2: When the oven beeps, remove, stir well and press start. When done, pour a cup full in a large flat plate. Spread as thin as possible with the back of a large flat spoon using circular outward movements. Allow to cool & cut into 1½ inch wide strips. Carefully roll each strip & Serve with chutney."</p>			

BREAKFAST/SNACKS

Category	Recipe-	Ingredients:	
BS10	BREAD CHIVDA	Bread Slices	250 gms
		Mustard Seeds	½ tsp
		Cumin Seeds	1 tsp
		Onion Finely Chopped	1
		Turmeric Powder	¼ tsp
		Hing	a pinch
		Curry Leaves	few
		Raw Peanuts	1 tbsp
		Oil As Required	
		Salt To Taste	
		Coriander Leaves For Garnish	
<p>Method of Preparation: "Step 1: Take a microwave oven safe bowl; add all the ingredients other than bread slices, hing and coriander leaves, mix well and select category, enter weight and press start. Step 2: When the oven beeps, remove and add all remaining ingredients other than the coriander leave and mix well and press start. Remove, garnish with grated coriander and serve."</p>			

Category	Recipe-	Ingredients:	
BS11	POHA	Poha	3 cup
		Green Peas	¾ tbsp
		Channa Dhal	1½ tsp
		Urad Dhal	1½ tsp
		Onions (Chopped)	2
		Green Chilli (Small Chopped)	3
		Carrot (Chopped)	¾ tbsp
		Turmeric Powder	¼ tsp
		Cumin Seeds	1 tsp
		Salt To Taste	
		Oil As Required	
		Grated Coconut For Garnish	
		Fresh Coriander For Garnish;	
<p>Method of Preparation: "Step 1: Take a microwave oven safe bowl; add all the ingredients other than pohe, salt, sugar, lime and garnish ingredients. mix well and select category, enter weight and press start. Step 2: When the oven beeps, remove and add the remaining ingredients other than garnish ingredients, mix well, cover the bowl with lid and place it in the microwave oven and press start. Remove, garnish with coriander and grated coconut. Serve hot."</p>			

BREAKFAST/SNACKS

Category	Recipe-	Ingredients:	
BS12	SABUDANA KICHDI	Sabudana (Soaked)	3 cup
		Ground Nut Powder	1½ cup
		Chopped Green Chillies	4
		Boiled & Peeled Potato	1 cup
		Oil	2 tbsp
		Hing	a pinch
		Cumin Seeds	¾ tsp
		Sugar	1½ tsp
		Lime Juice	¾ tsp
		Salt To Taste	
<p>Method of Preparation: "Step 1: Take a microwave oven safe bowl; add all the ingredients other than sabudana, salt, sugar and lime. mix well and select category, enter weight and press start. Step 2: When the oven beeps, remove and add the remaining ingredients and mix well. Cover the bowl with lid and place it in the microwave oven and press start. Remove and mix well and serve hot."</p>			

Category	Recipe-	Ingredients:	
BS13	ROTI KA CHIVDA	Leftover Chapattis, Cut In To Small Peices	4
		Mustard Seeds	½ tsp
		Cumin Seeds	1 tsp
		Onion Finely Chopped	1
		Turmeric Powder	¼ tsp
		Hing	a pinch
		Curry Leaves	few
		Raw Peanuts	1 tbsp
		Oil As Required	
		Salt To Taste	
		Coriander Leaves For Garnish	
<p>Method of Preparation: " Step 1: Take a microwave oven safe bowl; add all the ingredients other than chapatti, hing and coriander leaves, mix well and select Category, enter weight, press start Step 2: After the beep, remove, add the remaining ingredients other than the coriander leave, mix well and press start. Remove, garnish with grated coriander and serve."</p>			

BREAKFAST/SNACKS

Category	Recipe-	Ingredients:	
BS14	OMLETTE	Eggs - Beaten	4
		Onion - Finely Chopped	2
		Green Chillies - Finely Chopped	1 tsp
		Red Chilli Powder	1 tsp
		Oil	3 tsp
		Coriander Leaves For Garnish	
		Salt To Taste	

Method of Preparation:

"Step 1: Take a microwave oven safe bowl; add all the ingredients other than egg and coriander leaves. Mix well and select category, enter weight and press start.

Step 2: When the oven beeps, remove and add the beaten eggs, but not the coriander leaves, mix well and press start. Remove, garnish with coriander leaves and serve"

Category	Recipe-	Ingredients:	
BS15	MURMURA CHIDWA	Poha (Thin Flattened Rice)	1 cup
		Murmura (Puffed Rice)	2 cup
		Peanuts	1 cup
		Almonds	few
		Cashew Nuts	few
		Black Raisins	few
		Coconut Flakes	few
		Chopped Green Chillies	3
		Curry Leaves	few
		Mustard Seeds	½ tsp
		Turmeric Powder	¼ tsp
		Sugar	1 tsp
		Oil As Required	
		salt to taste	

Method of Preparation:

"Step 1: Take a microwave oven safe bowl; add all the ingredients other than the poha, murmura and sugar. Mix well and select category, enter weight and press start.

Step 2: When the oven beeps, remove and add the remaining ingredients, mix well and press start. Remove, and serve."

BREAKFAST/SNACKS

Category	Recipe-	Ingredients:	
BS16	IDLY	Idly batter	250 gr
Method of Preparation: Pour idly batter in lightly greased microwave safe idly stand. Pour some water in the bottom of the idly bowl and cover the bowl with lid. Place the bowl in the microwave oven, select category, enter weight & press start. Remove After the beep & serve hot with sambar and coconut chutney.			

Category	Recipe-	Ingredients:	
BS17	DOKHLA	Besan (Gram Flour)	2 cup
		Corn Flour	2 tsp
		Sugar	1½ tsp
		Turmeric Powder	½ tsp
		Citric Acid	1 tsp
		Soda-Bi-Carb	½ tsp
		Lemon Juice	2 tsp
		Mustard Seeds	¾ tbsp
		Green Chillies - Finely Chopped	2 tsp
		Amchoor Powder	½ tsp
		Salt To Taste	
		Oil As Required	
		Grated Coconut For Garnish	
		Coriander Leaves For Garnish	
		Water As Required	
Method of Preparation: "Take gram flour, curd, water, salt, mix well into a batter. Cover it and set aside for 4 hours to marinate. Add green chillies, ginger paste, turmeric, lime juice, oil, soda-bi-carb and mix into a smooth batter. Step 1: Pour into microwave oven safe lightly greased bowl, place in the microwave oven, select category, enter weight, and press start. For tampering use curry leaves, mustard seeds, oil, and green chillies. garnish with coriander leaves and grated coconut. Serve with chutney."			

BREAKFAST/SNACKS

Category	Recipe-	Ingredients:	
BS18	POP CORN	Pop Corn	250 gms
		Butter	2 tsp
		Red Chilli Powder (Optional)	½ tsp
		Turmeric Powder	½ tsp
		Salt To Taste	
Method of Preparation:			
"Step 1: Take a microwave oven safe large glass bowl, add all ingredients, mix well and place the bowl in the microwave oven, select category, set weight, press start. Remove and serve hot."			

Category	Recipe-	Ingredients:	
BS19	CHOCOLATE MUFFINS	Maida	1 cup
		Cocoa Powder	¼ cup
		Caster Sugar	½ tsp
		Dark Choc Bits	¼ cup
		Oil	2 tbsp
		Cup Milk	¼ cup
		Vanilla Extract	¼ tsp
		Eggs	1
Method of Preparation:			
"Step 1: Take a mixing bowl, add all ingredients to make a smooth batter, mix well and pour the batter in maffin tins and place the maffin tins in the microwave oven, select category, set weight, press start. Remove and serve hot."			

Category	Recipe-	Ingredients:	
BS20	CHOCOLATE BALLS	Milkmaid	1 cup
		Marie biscuit powder	1 cup
		Milk powder	½ cup
		Bournvita	½ cup
		Grated coconut	½ cup
Method of Preparation:			
Step 1: In a microwave oven safe glass bowl add milkmaid, marie biscuit powder, milk powder, bournvita. Mix well. Select category & press start. Allow to cool. Make balls out of the mixture. Roll out the balls in the grated coconut.Keep in refrigerator for half an hour.			

DESSERTS/ SOUPS

Category	Recipe-	Ingredients:	
DS1	KAJU KATLI	Roasted Cashew Nuts Powder	1½ cup
		Sugar	¾ cup
		Rose Water	1 tsp
		Cardamom Powder	¼ tsp
		Water As Required	
<p>Method of Preparation: "Step 1: Take a microwave oven safe bowl, Add sugar, cardamom powder and rose water, mix well and select category, enter weight, press start. Step 2: When the sugar melts off completely add the cashew nuts powder into it. Mix well and press start. After the beep, remove, mix well and blend the sugar syrup and powder. The mixture must be smooth. Pour the mixture in to a lightly greased baking dish. Set to cool and cut to it into desired shapes."</p>			

Category	Recipe-	Ingredients:	
DS2	APPLE PIE	Apples cut into slices	4 cup
		Corn starch	3 tbsp
		Honey	3 tbsp
		Raisins (optional)	3 tbsp
		Nutmeg to taste	
		Cinnamon to taste	
		Butter as required	
<p>Method of Preparation: "Marinate the apples with the all ingredients for ½ hour. Step 1: Arrange the marinate apples in a lightly greased baking dish and place the baking dish on the mesh rack in the microwave oven, select category, enter weight and press start. Turn once in-between."</p>			

Category	Recipe-	Ingredients:	
DS3	CARAMEL PUDDING	Milk	4 cup
		Sugar	2 cup
		Eggs	4
		Vanilla extract	¾ tsp
		water as required	
<p>Method of Preparation: Step 1: Take a grill safe deep bowl, add all the ingredients, mix well and place the bowl in on the mesh rack, select category, enter weight and press start. Remove, set to cool and refrigerate. Serve chilled.</p>			

DESSERTS/ SOUPS

Category	Recipe-	Ingredients:	
DS4	NAAN KHATAI	Maida	150 g
		Suji	50 g
		Powdered sugar	85 g
		Vanilla essence	1 tsp
		Butter	100 g
		Almonds & cashewnuts	A few

Method of Preparation:

"Cream the butter & sugar together till it turns fluffy. Add vanilla essence followed by maida & suji. Make a dough out of this mixture. Make medium sized balls & put cashewnut on the top of each piece.

Step 1: Arrange them on crusty plate and place the plate in on the grill mesh rack, Select category, enter weight & press start."

Category	Recipe-	Ingredients:	
DS5	BREAD PUDDING	bread crumbs	250 gms
		sugar	200 gram
		milk	¾ liter
		butter	50 gms
		chocolate	20 gram
		eggs (yolks& white suppurate)	4
		vanilla essence	1 tsp

Method of Preparation:

"Soak bread crumbs in milk and press dry, add butter mixed sugar, chocolate, egg yolks, Mix well and add vanilla essence, egg white, mix all ingredients well and set a side.

Step 1: Pour the pudding in lightly greased glass bowl and place it in the microwave, select category, enter weight and press start."

Category	Recipe-	Ingredients:	
DS6	KALAKAND	Condensed Milk	1 cup
		Crumbled Paneer	1½ cup
		Milk	¾ cup
		Cardamom Powder	½ tsp
		Nuts For Garnish	few

Method of Preparation:

Step 1: Take a microwave oven safe bowl, add all ingredients other than cardamom powder, nuts, mix well and select category, enter weight and press start. After the beep, remove and add cardamom powder, mix smoothly and garnish with nuts, cut it into desired shapes. Serve warm.

DESSERTS/ SOUPS

Category	Recipe-	Ingredients:	
DS7	APPLE CUSTARD	Apple Slices	2 cup
		Custard Powder	2½ tbsp
		Sugar	2½ tbsp
		Milk	2½ cup
Method of Preparation:			
Step 1: Take a microwave oven safe bowl, Add all ingredients other than apples, mix well and select category, enter weight, press start. After the beep, remove and add apples, mix well, set a side to cool. Serve warm or cool.			

Category	Recipe-	Ingredients:	
DS8	PEDA	Soft Khoya	250 gms
		Sugar Powdered	1 cup
		Cardamom Powder	¼ tsp
		Cardamom Seeds (Crushed)	¼ tsp
		Pistachios	few
Method of Preparation:			
Step 1: Take a microwave oven safe glass bowl, add all ingredients other than cardamom seeds and pistachios, mix well and select category, enter weight, press start. After the beep, remove and set to cool. When set well, make peda shape and garnish with cardamom seeds and pistachios on top and serve.			

Category	Recipe-	Ingredients:	
DS9	RICE KHEER	Rice	2 cup
		Milk	4 cup
		Cardamom Seeds	few
		Almonds	few
		Saffron Threads, Soaked	a pinch
		Pistachio Nuts	few
		Raisins (Optional)	few
		Sugar	1 cup
		Water As Required	
Method of Preparation:			
Step 1: Take a microwave oven safe bowl, add all the ingredients other than cardamom, almonds, saffron, pistachio and raisins mix well. Place the bowl in the microwave oven, select category, enter weight and press start.			
Step 2: When the oven beeps, remove and add cardamom, almonds, mix well and press start. After the beep remove and add all remaining ingredients, mix well and serve hot.			

DESSERTS/ SOUPS

Category	Recipe-	Ingredients:	
DS10	BROWNIE	Flour – Sifted	1½ cup
		Margarine	2 tbsp
		Sugar	1½ cup
		Baking Powder	1 tsp
		Cocoa Powder	¾ cup
		Walnuts	½ tbsp

Method of Preparation:

Mix the margarine and sugar in a mixing bowl until the sugar is completely dissolved. Add cocoa powder, flour, nuts, baking powder and mix well until smooth. Pour into a lightly greased flat glass bowl. Place in the microwave oven, select category, enter weight and press start. Remove, allow to cool and serve.

Category	Recipe-	Ingredients:	
DS11	BASUNDI	Milk	6 cups
		Sugar	2tbsp
		Chopped Almonds	6
		Lemon Juice	1½ tsp
		Crushed Cardamoms	6
		Chopped Charoli Nuts (Saara)	1 tsp

Method of Preparation:

Step 1: Take a microwave oven safe large bowl; add all ingredients other than almonds, cardamom and charoli, mix well. Place the bowl in the microwave oven, select category, enter weight and press start. Remove, add all remaining ingredients and serve.

Category	Recipe-	Ingredients:	
DS12	FRUIT CUSTURD	Custard Powder	1 cup
		Milk	5 cup
		Sugar	1 cup
		Apple	2
		Banana	3
		Pineapple Slices	½ cup
		Strawberries	½ cup
		Black Grapes (Seedless)	½ cup
		Green Grapes (Seedless)	½ cup
		Cherries To Garnish	½ cup

Method of Preparation:

"Step 1: Take a microwave oven safe large glass bowl; add milk, sugar and mix well. Place the bowl in the microwave oven, select category, enter weight and press start.

Step 2: When the oven beeps, remove and add custard powder, mix well and press start. Slice the apple, banana, pineapple into pieces and put them into a bowl which is large enough to hold all the contents. The grapes and the strawberries need not be cut and should be added along with it. Add custard to the fruits and mix gently. Set to cool and serve."

DESSERTS/ SOUPS

Category	Recipe-	Ingredients:	
DS13	SUJI KA HALWA	Suji - Roasted	2 cup
		Milk	2 cup
		Sugar	2 cup
		Ghee	1½ cup
		Cardamom Powder	1½ tsp
		Cashews	8
		Almonds	8
		Raisins	few
		Water As Required	
Method of Preparation: "Step 1: Take a microwave oven safe glass bowl; add the suji. Select category , enter weight, press start (Stir once in between). Step 2: When the oven beeps, remove and add all other ingredients mix well and press start. Serve hot."			

Category	Recipe-	Ingredients:	
DS14	COCONUT BURFI	Ghee	2 tbsp
		Grated Coconut	2 cups
		Khoya, Grated	1 cup
		Milk	1½ cups
		Sugar	1 cup
		Cardamom Powder	a pinch
		Chopped Pistachios	1 tbsp
		Saffron Strands	a pinch
Method of Preparation: Step 1: Take a microwave oven safe bowl, add all ingredients , mix well and select category , enter weight, press start. After the beep, remove and set to cool, cut in to required shapes and Serve.			

Category	Recipe-	Ingredients:	
DS15	PAYASAM	Milk	6 cups
		Vermicelli (Seviya)	1½ cups
		Sugar	1½ cup
		Cardamom	6
		Cashew Nuts	½ tbsp
		Almonds	½ tbsp
		Ghee	1 tbsp
Method of Preparation: "Step 1: Take a microwave oven safe bowl, add all the ingredients other than milk, sugar, cardamom, select category, enter weight, press start. Step 2: When the oven beeps, remove and add the remaining ingredients, mixwell and press start. Serve hot."			

DESSERTS/ SOUPS

Category	Recipe-	Ingredients:	
DS16	GAJAR HALWA	Carrots (Grated)	3 cup
		Kawa (Mawa Grated)	1 cup
		Sugar	2 cup
		Milk Condensed	1 cup
		Milk	1 cup
		Cardamoms	few
		Pistachio Flakes (Almonds)	few
		Ghee As Required	
		Raisins	few
Method of Preparation:			
"Step 1: Take a microwave oven safe bowl, add all the ingredients other than milk, condensed milk, cardamom, flakes and raisins, mix well and select category, enter weight, press start.			
Step 2: When the oven beeps, remove and add the remaining ingredients, mix well and press start."			

Category	Recipe-	Ingredients:	
DS17	SEVIYA KHEER	Seviya	3 cup
		Milk	6 cup
		Condensed Milk	1½ cup
		Sugar	1½ cup
		Raisins	1½ tbsp
		Cashew Nut Pieces (Roasted)	1½ tbsp
		Almonds (Roasted)	1tbsp
		Powdered Elaichi (Cardamom)	1½ tsp
		Water As Required	
Method of Preparation:			
"Step 1: Take a microwave oven safe bowl; add seviya and select category, enter weight, press start.			
Step 2: When the oven beeps, remove and add all the ingredients except elaichi powder and raisins mix well and press start.			
Step 3: When the oven beeps, remove and add all remaining ingredients. Mix well and press start. Serve hot."			

DESSERTS/ SOUPS

Category	Recipe-	Ingredients:	
DS18	PUMPKIN SOUP	Pumpkin	250 gms
		Chopped Onion	1 cup
		Green Chillies	2
		Garlic, Finely Chopped	3
		Curry Powder	1 tsp
		Chili Powder	1½ tsp
		Black Pepper	few
		Sugar	1½tsp
		Curry Leaves	few
		Chicken Broth	1 cup
		Evaporated Milk	1 cup
		Coconut Milk	1 cup
		Butter As Required	
		Salt To Taste	

Method of Preparation:

"Step 1: Take a microwave oven safe bowl, add all the ingredients other than pumpkin, chicken broth, evaporated milk and coconut milk, mix well and select category, enter weight, press start. Step 2: When the oven beeps, remove and add the remaining ingredients, mix well and press start."

Category	Recipe-	Ingredients:	
DS19	HOT & SOUR SOUP	Water	1½ cup
		Chilli sauce	2 tsp
		Soya sauce	2 tsp
		Vinegar	As per taste
		Chopped capsicum,	½ cup
		Spring onions	½ cup
		Carrots	½ cup
		Cabbage	½ cup
		Paneer	½ cup
		Tomato sauce	2 tbsp
		Cornflour	2 tbsp
		Pepper	1 tsp
		Sugar	1 tsp
		Ajinomoto	a pinch
		Salt to taste	

Method of Preparation:

"Step 1: In a microwave oven safe glass bowl add water, chili sauce, soya sauce, vinegar, sugar, salt, pepper powder and ajinomoto. Select category & press start. Step 2: When the oven beeps, stir well & add all the chopped vegetables, stir well & add corn flour, tomato sauce, paneer pieces & press start."

DESSERTS/ SOUPS

Category	Recipe-	Ingredients:	
DS20	VEGETABLE SOUP	Carrot - Chopped	½ cup
		Sweet Potato - Chopped	½ cup
		Onion - Chopped	½ cup
		Tomato Chopped	½ cup
		Vegetable Broth	2 cup
		Coconut Milk	1 cup
		Ginger Sliced	1 inch
		Garlic Chopped	2 clove
		Curry Powder	1 tsp
		Pepper Powder	1 tsp
		Salt To Taste	
<p>Method of Preparation: "Step 1: take a microwave oven safe bowl, add all the ingredients other than coconut milk & vegetable broth, mix well and select category, enter weight, press start. Step 2: When the oven beeps, remove and add coconut milk and vegetable broth mix well and press start. After the beep, Remove, allow to cool and blend in the vegetables in a juicer. Drain, reheat and serve."</p>			

PANEER/GHEE/ CURD

Category	Recipe-	Ingredients:	
PG1	PANEER	Milk	6 cup
		Curd	¼ cup
Method of Preparation: Step 1: Take a microwave oven safe bowl, add all the ingredients, mix well and select category, enter weight, press start. After the beep, remove and strain the milk in the cheesecloth. Drain the whey. Collect the cheesecloth together with the coagulated milk shredded tightly. Place it on a plate and keep a heavy weight on top of the cheesecloth. check after 30-40 minutes. the paneer would be set. once warm or cooled cut paneer into cubes or any shape.			

Category	Recipe-	Ingredients:	
PG2	GHEE	Butter Globules	3 cup
Method of Preparation: Step 1: Take a microwave oven safe deep glass bowl, add butter globules, mix well, cover the bowl with lid and select category, enter weight, press start. After the beep, remove and set to cool and store in a glass jar.			

Category	Recipe-	Ingredients:	
PG3	CURD	Milk	8 cup
		Curd	¼ cup
Method of Preparation: Step 1: Take a microwave oven safe deep glass bowl, add all ingredients, mix well and select category, enter weight, press start.			

FERMENTATION/KEEP WARM

Category	Recipe-	Ingredients:	
FE1	YOGURT	Curd	250 ml
		Milkmaid	100 ml
		Fresh cream	200 ml
		Essence	¼ tsp

Method of Preparation:

"Step 1: Select category, enter weight, press start to pre heat the oven. Take a mixing bowl, add all ingredients mix well.

Step 2: When the oven beeps, place the bowl in pre heated oven and press start."

Category	Recipe-	Ingredients:	
FE2	BREAD DOUGH	All-Purpose Flour	2 cups
		Warm Water	½ cup
		Active-Dry Yeast	2 tsp
		Unsalted Butter	1 tbsp
		Milk Powder	3 tbsp
		Sugar	1tsp
		Oil	2 tbsp
		Salt To Taste	
		Water As Required	

Method of Preparation:

Take warm water in a bowl, add dry yeast, sugar and 2 tsp flour, mix well and set a side for 5 minutes. Take another mixing bowl, add maida, oil, salt, milk powder, butter and dry yeast water, mix well to make a smooth, soft dough. Punch the dough for 10 minutes. Set it a side for 15 minutes. Punch the dough again for 5 minutes. Set the dough batter in a bowl. Select category & enter weight & press start.

Category	Recipe-	Ingredients:	
FE3	PIZZA DOUGH BATTER	All Purpose Flour (Maida)	2 cups
		Salt	1 tsp
		Dry Yeast	2 tsp
		Sugar	1 tsp
		Oil	3 tsp
		Oregano	1 tsp
		Chili Flakes	1 tsp
		Water As Required	

Method of Preparation:

Take half a cup of warm water, add sugar, yeast and a pinch of flour, stir and cover. Keep aside for 5 minutes. Sieve the flour, add salt, chili flakes, oregano and oil, mix well, add the yeast water. Make smooth and soft dough using of water as required. Set it aside for 15 minutes. Roll out the dough. Place on a dusted baking tray and prick with a fork. Cover and leave in the oven select category & enter weight & press start.

FERMENTATION/KEEP WARM

Category	Recipe-	Ingredients:	
FE4	DOSA BATTER	Parboiled Rice	½ cup
		Regular Rice	½ cup
		Urad Dal	¼ cup
		Methi Seeds	½ tsp
		Poha	3 tbsp
		Water For Soaking	
		Water For Grinding	
		Salt As Required	
		Oil As Required	
Method of Preparation:			
Soak & make a smooth batter with all above ingredients and take the batter in a large bowl, place it in the oven and select category, enter weight, press start.			

Category	Recipe-	Ingredients:	
FE5	JALEBI BATTER	All Purpose Flour	2 cup
		Besan	4 tbsp
		Turmeric Powder	1/8 tsp
		Baking Soda	1 pinch
		Water	2 cup
Method of Preparation:			
Soak & make a smooth batter with all above ingredients and take the batter in a large bowl, place it in the oven and select category, enter weight, press start.			

Category	Recipe-	Ingredients:	
FE6	IDLI BATTER	parboiled rice	½ cup
		regular rice	½ cup
		urad dal	¼ cup
		methi seeds	½ tsp
		poha	3 tbsp
		water for soaking	
		water for grinding	
		salt as required	
		oil as required	
Method of Preparation:			
Soak & make a smooth batter with all above ingredients and take the batter in a large bowl, place it in the oven and select category, enter weight, press start.			

FERMENTATION/KEEP WARM

Category	Recipe-	Ingredients:	
FE7	APPAM BATTER	Raw rice	2 cup
		Par boiled rice	2 cup
		Fenugreek seeds	2 tsp
		Urad dal	5 tbsp
		Coconut milk	6 tbsp
		Cooking soda	1 tsp
Method of Preparation: Soak & make a smooth batter with all above ingredients and take the batter in a large bowl, place it in the oven and select category, enter weight, press start.			

Category	Recipe-	Ingredients:	
FE8	NAAN DOUGH	All Purpose Flour	1 cup
		Wheat Flour	¼ cup
		Sugar	1 tsp
		Instant Yeast	½ tsp
		Water As Required	
		Curd	2 tbsp
		Butter, Melted	1 tbsp
		Salt As Required	
Method of Preparation: Take warm water in a bowl, add dry yeast, sugar, mix well and cover with lid, set a side for 5 minutes. Take another mixing bowl, Combine all the ingredients, including the yeast mixture and knead into a smooth, soft dough using enough water. Cover with a damp cloth and place it in the oven, Select category, enter weight & press start.			

Category	Recipe-	Ingredients:	
FE9	DHOKLA BATTER	gram flour	1½ cup
		rava (optional)	1 tbsp
		ginger-green chilies paste	3 tsp
		turmeric powder	¼ tsp
		asafoetida	a pinch
		baking soda	1 tsp
		lime juice	1 tsp
		water as required	
		salt to taste	
Method of Preparation: Combine all ingredients to make a smooth batter and pour the batter in a mixing bowl. Place it in the oven and select category, enter weight, press start.			

FERMENTATION/KEEP WARM

Category	Recipe-	Ingredients:	
FE10	KEEP WARM	Any Cooked Food	250 g
Method of Preparation: Place the cooked food bowl in the oven and select category, enter weight, press start.			

DEODORIZER/STEAM CLEAN

Category	Recipe-
DE	DEODORIZER
Method of Preparation: To use deodorizer press the category button once and press start.	

Category	Recipe-	Ingredients:	
SC	STEAM CLEAN	Water	1 cup
		Lime juice	1 tbsp
Method of Preparation: Take water in the microwave oven safe bowl, add lemon juice. To use steam clean, press the category button twice and press start. When the oven beeps, wipe the cavity with salt and clean napkin.			

CLEANING AND CARE

1. Turn off the oven and remove the power plug from the wall socket before cleaning.
2. Keep the inside of the oven clean. When food splatters or spilled liquids adhere to oven walls, wipe with a damp cloth. Mild detergent may be used if the oven gets very dirty. Avoid the use of spray and other harsh cleaners as they may stain, streak or dull the door surface.
3. The outside surfaces should be cleaned with a damp cloth. To prevent damage to the operating parts inside the oven, water should not be allowed to seep into the ventilation openings.
4. Wipe the door and window on both sides, the door seals and adjacent parts frequently with a damp cloth to remove any spills or spatters. Do not use abrasive cleaner.
5. Do not allow the control panel to become wet. Clean with a soft, damp cloth. When cleaning the control panel, leave oven door open to prevent oven from accidentally turning on.
6. If steam accumulates inside or around the outside of the oven door, wipe with a soft cloth. This may occur when the microwave oven is operated under high humidity condition. And it is normal.
7. It is occasionally necessary to remove the glass tray for cleaning. Wash the tray in warm sudsy water or in a dishwasher.
8. The roller ring and oven floor should be cleaned regularly to avoid excessive noise. Simply wipe the bottom surface of the oven with mild detergent. The roller ring may be washed in mild sudsy water or dishwasher. When removing the roller ring from cavity floor for cleaning, be sure to replace in the proper position.
9. Remove odors from your oven by combining a cup of water with the juice and skin of one lemon in a deep microwaveable bowl, microwave for 5 minutes. Wipe thoroughly and dry with a soft cloth.
10. When it becomes necessary to replace the oven light, please consult the nearest service center to have it replaced
11. The oven should be cleaned regularly and any food deposits removed. Failure to maintain the oven in a clean condition could lead to deterioration of the surface that could adversely affect the life of the appliance and possibly result in a hazardous situation.
12. Please do not dispose this appliance into the domestic rubbish bin; it should be disposed to the particular disposal center provided by the municipalities

TROUBLE SHOOTING

Before calling for service check the following list to be sure that a service call is necessary. Reviewing additional information on items in the following table may prevent an unneeded service call

PROBLEM	POSSIBLE CAUSE
If nothing on the oven operates	<ul style="list-style-type: none"> - Check for a blown circuit fuse or a tripped main circuit breaker - Check if oven is properly connected to the electric circuit in house - Check if controls are set properly
If oven does not work	<ul style="list-style-type: none"> - Check that the control panel was programmed correctly - Check that the door is firmly closed - Check that Start/Enter pad was touched
If oven takes longer than normal to cook or cooks too rapidly	<ul style="list-style-type: none"> - Be sure the power level is programmed properly
If the time of the day clock does not always keep the correct time	<ul style="list-style-type: none"> - Check that the power cord is fully inserted into the power outlet - Be sure the oven is the only appliance in the electrical circuit
If food cooks unevenly	<ul style="list-style-type: none"> - Be sure that the food is evenly placed - Be sure that the food is completely defrosted before cooking - Check placement of aluminum foil strips used to prevent over cooking
If food is under cooked	<ul style="list-style-type: none"> - Check recipe to be sure all directions (amount, time and power levels) were correctly followed - be sure the oven is the only appliance in the electrical circuit - Be sure that the food is completely defrosted before cooking
If food is over cooked	<ul style="list-style-type: none"> - Check recipe to be sure all directions (amount, time power levels & size of dish) were correctly followed
If arcing (sparks) occur	<ul style="list-style-type: none"> - Be sure microwavable dishes were used. - Be sure wire-twist ties were not used - Be sure that the oven was not operated when empty - Be sure that metal racks is not used in the microwave mode

FREQUENTLY ASKED QUESTION

QUESTION	ANSWER
Can I use a rack in my microwave oven so that I may reheat or cook in two rack positions at a time?	<p>It is recommended that while using the microwave mode to cook or reheat, place food on the turn table only.</p> <p>The metal rack provided along with the microwave oven (*Select models) is not to be used in the microwave mode.</p> <p>Only use the rack that is supplied with your microwave oven in the grill, combination or convection mode.</p> <p>Use of any other rack can result in poor cooking performance and/or arcing and may damage your oven.</p> <p>DO not use metal rack during Microwave or Combination (Micro +Grill, Micro + Convection) Cooking program.</p>
Can I use either metal or aluminum pans in my microwave oven?	<p>Usable metal includes aluminum foil for shielding (use small, flat pieces).</p> <p>Never allow metal to touch the walls or door.</p>
Sometimes the door of my microwave oven appears wavy. Is this normal?	This appearance is normal and does not affect the operation of your oven.
What are the humming noises I hear when my microwave oven is operating?	This is the sound of the transformer when the magnetron tube cycles on and off.
Why does the dish become hot when I microwave food in it?	<p>As the food becomes hot, it will conduct the heat to the dish. Use hot pads to remove food after cooking.</p> <p>The dish may not be microwave safe.</p>
What does standing time mean?	Standing time means that food should be left in the oven for a short period of time after the cooking is over which allows the cooking to finish
Can I pop popcorn in my microwave oven? How do I get the best results?	<p>Yes. Pop packaged microwave popcorn following manufactures guideline or use the pre programmed popcorn pad.</p> <p>Do not use regular paper bags.</p> <p>Use the listening test by stopping the oven as soon as the popping slows to a pop every 1 to 2 secs. Do not try to repop unpopped kernels.</p>
Why does steam come out of the air exhaust vent?	Steam is normally produced during cooking. The microwave oven has been designed to vent this steam out the top vent.

MICROWAVE OVEN WARRANTY

The Godrej Microwave Oven comes with a FOUR years warranty on the magnetron and a ONE year warranty (except for plastic parts, glass components and decorative strips, knobs etc.) against defective material or workmanship on all components of the microwave oven. Godrej & Boyce Mfg. Co. Ltd. Appliance Division undertakes repairs, free of charge during the warranty period.

INSTRUCTIONS FOR THE CUSTOMER

1. Kindly ensure that the dealer fills the warranty details correctly and completely.
2. You should retain the warranty page for record and produce the same in the event of any warranty repairs.
3. In the event of a defect developing in the product, contact the nearest authorised Godrej & Boyce Service Centre for obtaining warranty service and inform the defect, model details and Serial No.

TERMS AND CONDITIONS

1. Repairs and replacement of parts will be carried out through the authorised customer service centre.
2. For units installed beyond the municipal limits of the jurisdiction of the authorised customer care centre all expenses incurred in collecting the units or parts thereof from the company's customer care centre, as well as expenses incurred with depositing of service personnel/technician's towards conveyance and other incidents will be borne by the customer.
3. The concerned customer care centre will advise the customer whether to effect the repair at site or at the customer care centre.
4. While the company will make every effort to carry out the repairs at the earliest, it however is made expressly clear that the company is under no obligation to do so in a specified period of time.
5. The company or Its authorised customer care centre/service dealer reserves the right to retain any parts, components replaced at it's discretion.
6. Warranty does not cover accessories to the equipment.
7. The warranty is confined to the first purchaser of MWO only and non-transferable.
8. Call registered with the centralised helpline/authorised service centre, where in only cleaning of the unit/parts in the unit due to dust accumulation on portions of the units are not to be considered as defects.
9. **In case of any damages to the product, customer abuse, repairs by unauthorised personnel & misuse detected by the authorised service centre personnel, the warranty conditions are not applicable.**
10. If any coloured internal or external components are replaced, effort will be made to ensure that the shades match with the original or other components. However, the replaced shades, pattern, tints may vary from the customer's unit due to usage of the unit. Any matching components changed at customer's request will be charged, except the component which is actually needed.
11. **The unit shall be operated with variation +/-5% of the rated voltage. Fluctuation beyond specified tolerance will not be covered under warranty. Customer shall not operate the product below 210V under any circumstances.**
12. Parts not covered - Main door, Glass, Bulb, Rubber, Plastic Components.
13. This warranty does not cover any type of painting, plating including rusting etc. or defects thereof.
14. **The Appliance or any part thereof is subjected to neglect, abuse or misuse, tampering, alteration, accident, fire, floods or other acts of God, or Damage by rodents or insects, the COMPANY is not responsible for any damage caused to the appliance & Shall not be liable for any consequential loss or compensation. nor refund of purchase price or replacement of the appliance.**

Godrej & Boyce Mfg. Co. Ltd.- Appliance Division

MODEL NO.

UNIT SR. NO.

CUSTOMER'S NAME & ADDRESS _____ _____ _____
TEL. _____

WARRANTY DETAILS

UNIT SR. NO.

DEALER'S NAME & ADDRESS _____ _____ _____
TEL. _____

Customer's Signature:

Dealer's Signature:

This card is valid only if it is filled in and stamped by our authorised dealer on the date of purchase.

Warranty is Void If:

1. The warranty card is not completed properly at the time of purchase.
2. The completed warranty card is not presented to the authorised personnel at the time of service of the product.
3. The microwave is not operated according to instructions given in the 'User Guide'.
4. Defects are caused by improper or reckless use, which shall be determined by the company personnel.
5. Any repair work earned out by persons other than authorised company personnel.
6. Defects caused beyond control like abnormal voltage, acts of God, or while in transit to service centre or purchaser's residence.
7. The warranty is not valid in case the serial number is deleted, defaced or altered.
8. Damage to the microwave or any parts due to transportation or shifting is not covered by the warranty.
9. The warranty automatically expires after 12 month of original date of purchase, even if the microwave may not be in use for any time for whatever reasons during the warranty period.

GODREJ & BOYCE MFG. CO. LTD., Appliances Division

Branch	Address
Ahmedabad	4th Floor, APM Shopping Mall Near IOCL Petrol Pump, Shyamal-Karnavati, 100 ft. Road, Satellite, Ahmedabad - 380 015
Bangalore	3rd Floor, The Karnataka Film Chamber of Commerce Bldg. 28, 1st Main, Crescent Road, High Grounds Nr. Shivanand Circle, Bangalore - 560 001
Bhopal	217, Zone I, M.P. Nagar, Beh. Jyoti Talkies, Bhopal - 462 011
Bhubaneshwar	Highway Complex, NH-5, Rudrapur, Bhubaneshwar - 752 101
Chandigarh/Mohali	Plot No. A-40, Phase VIII-A, Industrial Area, Mohali - 160 059
Chennai	No. 1, Sidco Industrial Estate, Ambattur, Chennai - 600 098
Coimbatore	No. 585 - 590 3rd Floor, Sathya Towers, DB Road, R S Puram, Coimbatore - 641002
Delhi	Godrej Bhavan, 2nd Floor, Shershah Suri Marg, Mathura Road, Okhla, New Delhi - 110 065
Faridabad	Godrej Bhavan, 2nd Floor, Shershah Suri Marg, Mathura Road, Okhla, New Delhi - 110 065
Ghaziabad	Plot No. 229/230, Sardar Pashu Ahaar, Bulandshahar Road, Village-chaprolia, Ghaziabad
Guwahati	Basundhara Enclave, 1st & 2nd Floor Ulubari, Guwahati - 781007
Hyderabad	201 & 202, Lala-1 Land Mark, 5-4-94 to 97, 2nd Floor, Above Digital Shoppy, Ranigunj, M.G. Road, Secunderabad -500 003
Jaipur	502-506, 5th Floor, Gaurav Towers, Malviya Nagar, Jaipur - 302 017
Kochi	2nd floor, Angels Arcade, South Kalamasserry, Near CUSAT PO Kochi - 682022
Kolkata	Plot-30, Block-GN, Sector-V, Salt Lake city, Kolkata - 700 091
Lucknow	C-3/3 & C-3/4, Sanjay Complex, Near All India Radio, Vidhan Sabha Marg, Lucknow-226001
Mumbai	Appliance Division, Plant 4, Pirojshahnagar, Vikhroli, Mumbai - 400 079
Nagpur	Dr. Bhiwapurkar Chamber, 2nd Floor, Opp. Yashwant Stadium, Dhantoli, Nagpur - 440 012
Patna	Grand Plaza 6th Floor, 6001-6004, Dakbunglow Crossing, Frazer Road, Patna-800001
Pune	Apollo Building Square, Plot No. 60, Survey No. 599, Sahaney Sujan Park, Lullanagar, Bibewadi Road, Pune - 411 040
Raipur	9/1, Besides Bharat Petrol Pump, Opp, Hotel Picadelly, Mahoba Bazaar, G.E. Road, Raipur - 492 001, Chhatisgarh
Ranchi	C/o. Surya Motors, Near Krishi Bazaar Samiti Pandra, Ranchi (Jharkand) - 835 222
Toll-Free : 1800-209-5511	
Website: www.godrejappliances.com & www.godrejsmartcare.com E-mail: smartcare@godrej.com	

Protection of Environment:

Protection of environment" is one of the core values of Godrej and we seek your co-operation to make sure that the product, packaging and plastic material is not disposed as unsorted municipal waste.



This symbol is known as the "Crossed-out Wheellie Bin Symbol". It means that the product should not be disposed of with your general house-hold waste.

It should be disposed of only through the company's collection points with special treatment so as to prevent any damage to the environment. Please call: **1800 209 5511** for applicable buy back arrangement or **visit: www.godrejappliances.com/green-think** for details about Godrej Appliances authorised collection points.

Godrej | APPLIANCES