

Godrej eon®

HOW TO GET THE BEST OUT OF YOUR GODREJ MICROWAVE OVEN...



User Manual

GME 30CR1 BIM

**30 Ltr. Microwave, Grill, Convection,
& Rotisserie**

Thank you for purchasing Godrej Microwave Oven

Please record the model number and serial number of this unit for future reference.

Staple your receipt here for proof of purchase.

Model No: _____

Serial No: _____

Dealer: _____

Dealer Phone No: _____

SPECIFICATIONS

Model	GME 30CR1 BIM
Rated Voltage	230 V~50 Hz
Rated Input Power (Microwave)	1450W
Rated Output Power (Microwave)	900W
Rated Input Power (Grill)	1100W
Rated Input Power (Convection)	2500W
External Dimensions:	520mm(W)×480mm(D)×335mm(H)
Turn Table Diameter:	315mm
Oven Capacity:	30Litres
Net Weight:	Approx. 20.3 kg

TABLE OF CONTENT

IMPORTANT SAFETY INSTRUCTIONS	4
UTENSIL GUIDE	6
INSTALLATION INFORMATION	6
GROUNDING INSTRUCTIONS	6
ELECTRICAL REQUIREMENTS	7
RADIO INTERFERENCE	7
EXTENSION CORD INFORMATION	7
PART NAMES	7
CONTROL PANEL	9
OPERATION INSTRUCTIONS	10
INSTACOOK MENUS	16
CLEANING AND CARE	22
TROUBLESHOOTING	23
FAQs	24
WARRANTY	25

IMPORTANT SAFETY INSTRUCTIONS

READ CAREFULLY AND KEEP FOR FUTURE USE

Important Safety instructions

The Safety instructions mentioned below will tell you how to use your Microwave Oven without harming yourself and damaging your oven.

Warning – To reduce the risk of burns, electric shock, fire, injury to persons, or exposure to excessive microwave energy

- Read all the instructions before using your oven
- Do not allow children to use this oven without close supervision

Precautions to avoid possible exposure to excessive microwave energy:

- Do not attempt to operate this oven with the door open since open door operation can result in harmful exposure to microwave energy. It is important not to tamper with the safety interlocks.
- Do not place any object between the microwave oven cavity and the door or allow soil or cleaner residue to accumulate on sealing surfaces
- Do not operate the oven if it is damaged. It is particularly important that the oven door closes properly and that there is no damages to the:
 - Door (bent)
 - Hinges and latches (broken or loosened)
 - Door seals and sealing surfaces
- It is hazardous for anyone other than properly qualified competent service personnel to repair, adjust or remove the cover which gives protection against exposure to microwave energy

1. **Do not heat the following items in the microwave oven:** Whole eggs in the shell, water with oil or fat, sealed containers, or closed glass jars.

These items may explode.

- Do not cover or block any openings in the oven
- Use your oven only for the operations described in this manual
- Do not run the oven empty, without food in it
- Do not deep fry in your microwave oven
- Do not remove the turn table while using the microwave oven

- Do not make popcorn, peanuts and suji roast in plastic utensil. Use only microwaveable glass utensil.
- Only use utensils suitable for use in microwave oven
 - Remove wire twist-ties and metal handles from paper or plastic containers/bags before placing them in the oven
 - The oven should be cleaned regularly and any food deposits should be removed. Failure to maintain the oven in a clean condition could lead to deterioration of the surface, and could adversely affect the life of the appliance and possibly result in a hazardous situation.
 - When the appliance is operated in the combination mode, children should only use the oven under adult supervision due to the temperatures generated.
 - To avoid a fire hazard do not severely overcook food. Severely overcooked foods can start a fire in the oven.
 - When heating food in plastic or paper containers, keep an eye on the oven due to the possibility of ignition.
 - If smoke is observed, switch off or unplug the appliance and keep the door closed in order to stifle any flames
 - Do not use the cavity for storage purposes. Do not leave paper products, cooking utensils, or food in the cavity when not in use.
 - Do not use this oven for commercial purposes. This appliances is intended to be used in household and similar application such as:
 - Staff Kitchen areas in shops, offices and other working environments;
 - Farm Houses;
 - By clients in hotels, motels and other residential environments;
 - Bed and breakfast type environments.
 - When cleaning the door and the surfaces that touch the door, use only mild, non-abrasive soaps or detergents and a sponge or soft cloth
 - Do not use corrosive chemicals or vapours, in this appliance. This type of oven is specifically designed to heat, cook, or dry food. It is not designed for industrial or laboratory use

13. Do not use or store this appliance outdoors. Do not use this product near water for example near a kitchen sink, in a wet basement, or near a swimming pool, and the likes.
14. Do not tamper with the built-in safety switches on the oven door. The oven has several built-in safety switches to make sure the power is off when the door is open.
15. If the supply cord is damaged, it must be replaced by the manufacturer, its service agent or similarly qualified persons in order to avoid a hazard
16. If your oven is dropped or damaged, have it thoroughly checked by a qualified service technician before using it again
17. The temperature of accessible surfaces may be high when the appliance is operating. Keep cord away from heated surface, and do not cover the oven.
18. Do not immerse the electrical cord or plug in water
19. Pierce food with heavy skin such as potatoes, whole squashes, apples, tomatoes, brinjals, mutton, chicken before cooking
20. Cooking utensils may become hot because of heat transferred from heated food. Potholders may be needed to handle the utensils. Utensils should be checked to ensure that they are suitable for use in microwave ovens.
21. The microwave oven shall not be placed in a cabinet
22. Liquids, such as water, coffee, or tea can be overheated beyond the boiling point without appearing to be boiling. Visible bubbling or boiling when the container is removed from the microwave oven is not always present. **THIS COULD RESULT IN VERY HOT LIQUIDS SUDDENLY BOILING OVER WHEN THE CONTAINER IS DISTURBED OR A SPOON OR OTHER UTENSIL IS INSERTED INTO THE LIQUID.**
23. To reduce the risk of injury to persons:
 - Do not overheat the liquid
 - Stir the liquid both before and halfway through heating it
 - While cooking or reheating in microwave mode, ensure the vent of the lid is kept open at all times or the lid is partially open
 - After heating, allow the container to stand in the microwave oven for a short time before removing the container
 - Use extreme care when inserting a spoon or other utensil into the container
24. The contents of feeding bottles and baby food jars shall be stirred or shaken and the temperature checked before consumption, in order to avoid burns
25. The appliances is not intended for use by persons (including children) with reduced physical, sensory or mental capabilities, or lack of experience and knowledge, unless they have been given supervision or instruction concerning use of the appliance by a person responsible for their safety
26. The rear surface of the appliance shall be placed against the wall
27. Microwave oven is intended for heating food and beverages. Drying of food or clothing and heating of warming pads, slippers, sponges, damp cloth and similar may lead to risk of injury, ignition or fire.
28. Microwave heating of beverages can result in delayed eruptive boiling, therefore care must be taken when handling the container.
29. Details for cleaning door seals, cavities and adjacent parts are given on page **CLEANING AND CARE.**
30. No temperature sensing probe to be inserted into the food placed inside the cavity of this oven by user, during switched ON state.
A temperature probe may be placed on the food once the food is taken outside the oven.
31. The microwave is intended to be used freestanding.

UTENSIL GUIDE

1. The ideal material for a microwave utensil is transparent to microwave, it allows energy to pass through the container and heat the food.
2. Microwave cannot penetrate metal, so metal utensils or dishes with metallic trim should not be used.
3. Do not use recycled paper products when microwave cooking, as they may contain small metal fragments which may cause sparks and/or fires.
4. Round /oval dishes rather than square/oblong ones are recommend, as food in corners tends to overcook.
5. Narrow strips of aluminum foil may be used to prevent overcooking of exposed areas. But be careful don't use too much and keep a distance of 1 inch (2.54cm) between foil and cavity.

The list below is a general guide to help you select the correct utensils.

Cookware	Microwave	Grill	Convection	Combination*
Heat-Resistant Glass	Yes	Yes	Yes	Yes
Non Heat-Resistant Glass	No	No	No	No
Heat-Resistant Ceramics	Yes	Yes	Yes	Yes
Microwave-Safe Plastic Dish	Yes	No	No	No
Kitchen Paper	Yes	No	No	No
Metal Tray	No	Yes	Yes	No
Metal Rack	No	Yes	Yes	No
Aluminum Foil & Foil Container	No	Yes	Yes	No

* Combination: applicable for both "microwave+grill", and "microwave+convection" cooking.

INSTALLATION INFORMATION

- 1) Select a level surface that provides enough open space for the intake and/or outlet vents

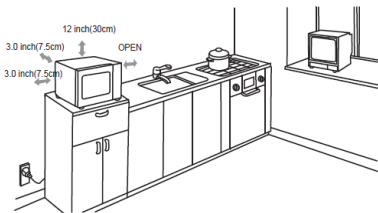

A minimum clearance of 7.5 cm is required between the oven and any adjacent walls. One side must be open.

- a) Leave a minimum clearance of 30 cm above the oven.
- b) Do not remove the legs from the bottom of the oven.

- c) Blocking the intake and/or outlet openings can damage the oven
- d) Place the oven as far away from radios and TV as possible

- 2) Plug your oven into a standard household outlet. Be sure the voltage and frequency is the same as the voltage and the frequency on the rating label at the back of the Microwave Oven.

- 3) Do not operate the oven without glass tray, roller support and shaft in their proper positions (applicable for microwave ovens with turn tables)

WARNING: Do not install oven over a range cooktop or other heat-producing appliance. If installed near or over a heat source, the oven could be damaged and the warranty would be void.

GROUNDING INSTRUCTIONS

This appliance must be grounded. This oven is equipped with a cord having a grounding wire with a grounding plug. It must be plugged into a wall receptacle that is properly installed and grounded. In the event of an electrical short circuit, grounding reduces risk of electric shock by providing an escape wire for the electric current. It is recommended that a separate circuit serving only the oven be provided. Using a high voltage is dangerous and may result in a fire or other accident causing oven damage.

WARNING Improper use of the grounding plug can result in a risk of electric shock.

Note:

- 1) If you have any questions about the grounding or electrical instructions, consult a qualified electrician or service person.
- 2) Neither the manufacturer nor the dealer can accept any liability for damage to the oven or personal injury resulting from failure to observe the electrical connection procedures.

The wires in this mains cable are colored in accordance with the following code:
Green and/or Yellow = EARTH
Blue and/or Black = NEUTRAL
Brown and/or Red = LIVE

ELECTRICAL REQUIREMENTS

The oven is designed to operate on a standard 230V~50Hz household outlet. Be sure the circuit is at least 15A or 20A and the

microwave oven is the **only appliance on the circuit**

RADIO INTERFERENCE

Operation of the microwave oven can cause interference to your radio, TV, or similar equipment.

When there is interference, it may be reduced or eliminated by taking the following measures:

1. Clean door and sealing surface of the oven.
2. Reorient the receiving antenna of radio or television.
3. Relocate the microwave oven with respect to the receiver.
4. Move the microwave oven away from the receiver.
5. Plug the microwave oven into a different outlet so that microwave oven and receiver are on different branch circuits.

EXTENSION CORD INFORMATION

1. A short power supply cord is provided to reduce the risks resulting from becoming entangled in or tripping over a longer cord
2. DO NOT USE AN EXTENSION CORD

PART NAMES

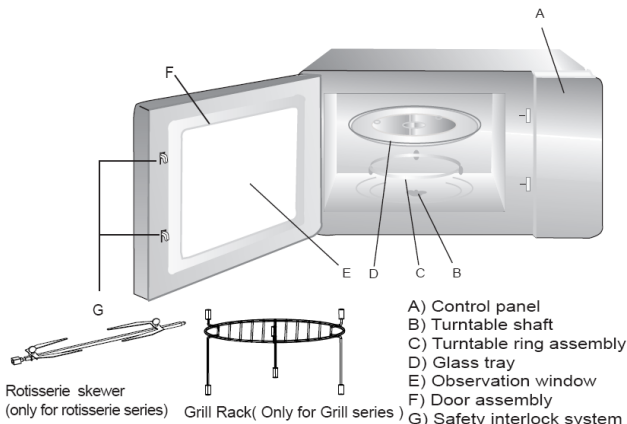

Rotisserie Skewer Installation

After putting the food on the rotisserie skewer, firstly, connection part 1 of the rotisserie skewer should be aimed at the shaft of the rotary motor. Then the shaft is put into the hole of the connection part. Secondly, put the supporting part 2 of the rotisserie skewer to the upside of the rotisserie skewer which is on the profile of the cavity. There is a semicircular position in the middle of the supporting part, the food can be put on it.

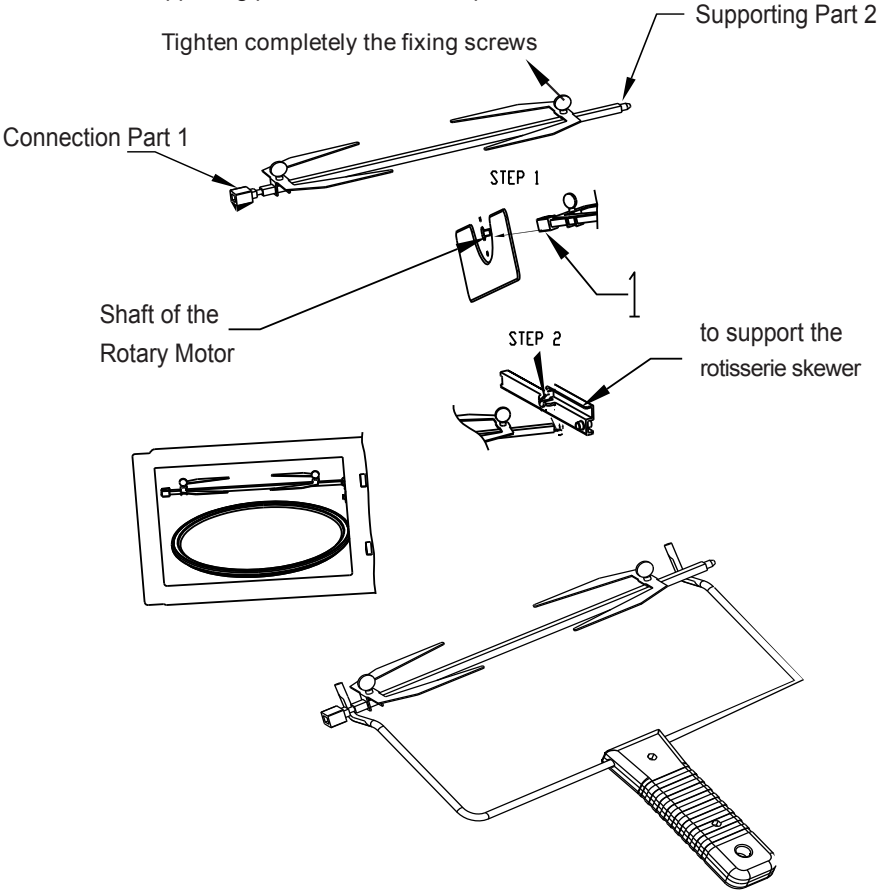

<p>Don't put the rotisserie skewer without food into the oven.</p>	<p>Tighten completely the fixing screws.</p>
--	--

Warning: using the rotisserie skewer under microwave is forbidden.

Control Panel and Features

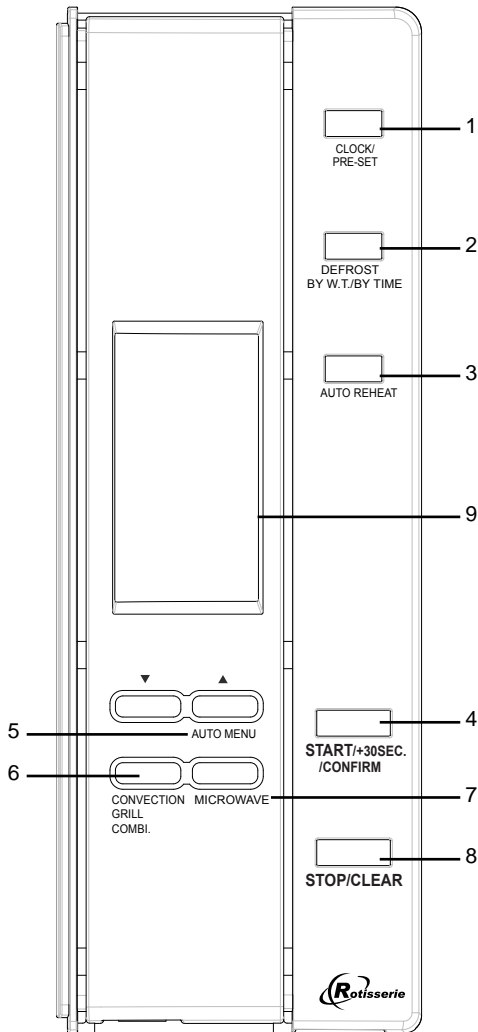

1. CLOCK/PRE-SET
2. DEFROST BY W.T./BY TIME
3. AUTO REHEAT
4. START/+30SEC./CONFIRM
5. AUTO MENU
6. CONVECTION/GRILL/COMBI.
7. MICROWAVE
8. STOP/CLEAR
9. DISPLAY

Operation Instructions

This microwave oven applies modern electronic control to adjust cooking parameters to meet your needs better for cooking.

1. Clock Setting

When the microwave oven is electrified, the LED will display "0:00", buzzer will ring once.

1) Press "**Clock/Pre-Set**" once or twice to choose 24 hours or 12 hours system, and 24H or 12H will be displayed.

2) Press " ▲ " or " ▼ " to adjust the hour figures, the input time should be within 0--23(for 24H) or 1--12(for 12H).

3) Press "**Clock/Pre-Set**", the minute figures will flash.

4) Press " ▲ " or " ▼ " to adjust the minute figures, the input time should be within 0--59.

5) Press "**Clock/Pre-Set**" to finish clock setting. ":" will flash and the time will light.

6) If you want to reset the clock, just to follow the above steps. If the "**Clock/Pre-set**" is not pressed to confirm, press "Stop/ Clear" or no operation within 1 minute, the clock that has been set will be canceled.

Note: 1. When power is supplied, time will not count (show 0:00) if clock is not set.
2. During setting the clock, if you press " **Stop/Clear** " key, the clock setting will be exit .

2. Microwave Cooking

Press "**Microwave**" different times to choose different microwave power, and "P100, P80, P50, P30, P10" will be displayed in cycle. Then press "▲" or "▼" to adjust the cooking time (up to 95 minutes). Press "**Start/ +30SEC./ Confirm**" to start cooking.

Example: If you want to use 50% power to cook for 20 minutes, you can operate the oven as the following steps.

1) Keep pressing " **Microwave** " till "P50" displays. And " ☺ " will light.

2) Press " ▲ " or " ▼ " to adjust the cooking time till the oven displays "20:00".

3) Press "**Start/ +30SEC./ Confirm**" to start cooking. ":" will light and " ☺ " will flash. Five beep will sound when cooking finishes.

Power	100%	80%	50%	30%	10%
Display	P100	P80	P50	P30	P10

Note: the step amount of the pressing of " ▲ " and " ▼ " keys are:

0----1 min	:	step 5 seconds
1----5 min	:	step 10 seconds
5----10 min	:	step 30 seconds
10----30 min	:	step 1 Minute
30----95 min	:	step 5 Minutes

3. Convection Cooking(with preheating function)

1) Press " **Convection/ Grill/ Combi.**", "140", "°C" will flash in the display, and " ☼ " will light. Choose different temperature by pressing "▲" or "▼" from 140°C to 230°C.

2) Press "**Start/ +30SEC./ Confirm**" to confirm the temperature.

3) Press "**Start/ +30SEC./ Confirm**" again to start preheating.

4) The temperature figure will flash when temperature arrives in advance and buzzer will ring twice reminding you to put food in, then close the door.

5) Press " ▲ " or " ▼ " to adjust the cooking time, the maximum time that can be set is 95 minutes.

6) Press "**Start/ +30SEC./ Confirm**" to start cooking, and the cooking time counts down. At the same time, ":" will light, " ☼ " will flash.

Note: a. Cooking time cannot be input until the preheating temperature arrives.

If the temperature arrives, door must be opened to input the cooking time.

b. If the time not input in 5 minutes, the oven will stop preheating. The buzzer sound five times and turn back to waiting states.

4. Convection Cooking(without preheating function)

1) Press " **Convection/ Grill/ Combi.**", "140" will flash in the display, and " ☼ " will light. Choose different temperature by pressing "▲" or "▼" from 140°C to 230°C.

2) Press "**Start/ +30SEC./ Confirm**" to confirm the temperature.

3) Press " ▲ " or " ▼ " to adjust the cooking time, the maximum time that can be set is 95 minutes.

4) Press "**Start/ +30SEC./ Confirm**" to start cooking, and the cooking time counts down. At the same time, ":" will light, " ☼ " will flash.

5. Grill Cooking

1) Press "**Convection/ Grill/ Combi.**", "140" will flash in the display, and "☼" will light. Choose grill function by pressing "▲" or "▼", and "G-1" will flash "∩∪" will display.

2) Press "**Start/ +30SEC./ Confirm**" to confirm the grill function.

3) Press " ▲ " or " ▼ " to adjust the cooking time, the maximum time that can be set is 95 minutes.

4) Press "**Start/ +30SEC./ Confirm**" to start cooking, and the cooking time counts down. At the same time, ":" will light, "∩∪" will flash.

Note: If half the grill time passes, the oven sounds twice to tell you to input the time. You can just leave it continue. But in order to have a better effect of grilling food, you should turn the food over, close the door, and then press "Start/ +30SEC./ Confirm" to continue cooking. If there is no operation, the oven will not pause and continue working.

6. Combination Cooking

1) Press "**Convection/ Grill/ Combi.**", "140" will flash in the display, and "☼" will light. Choose combination function by pressing "▲" or "▼", and "C-1, C-2, C-3, or C-4" will flash under this function. The related indicators will light.

2) Press "**Start/ +30SEC./ Confirm**" to confirm the combination function.

3) Press " ▲ " or " ▼ " to adjust the cooking time, the maximum time that can be set is 95 minutes.

4) Press "**Start/ +30SEC./ Confirm**" to start cooking, and the cooking time counts down. At the same time, ":" will light, and the related indicator will flash.

Function	Display	Microwave	Grill	Convection
Combi.1	C-1	●		●
Combi.2	C-2	●	●	
Combi.3	C-3		●	●
Combi.4	C-4	●	●	●

7. Defrost By Weight

- 1) Press "**Defrost By W.T./By Time**" once. "d-1" will be displayed.

- 2) Press " ▲ " or " ▼ " to adjust defrost weight. The "g" indicator will light, "☺" and "✖" indicators light. And the weight input should be 100-2000g.

- 3) Press "**Start/ +30SEC./ Confirm**" to start defrosting. The buzzer sounds once, and "☺", "✖" indicators will flash.

8 Defrost By Time

- 1) Press "**Defrost By W.T./By Time**" twice . "d-2" will be displayed.

- 2) Turn " ▲ " or " ▼ " to select the cooking time. "☺" and "✖" will light. The time input should be 00:05-95:00.

- 3) Press "**Start/ +30SEC./ Confirm**" to start defrosting. Buzzer sounds once, and "☺", "✖" will flash.

9. Multi-section cooking

At most 3 sections can be input for cooking. In multi-section cooking, if one section is defrosting, then defrosting shall be placed in the first section. When one stage finish, buzzer sounds once and the next stage begins.

Note: Auto menu cooking cannot work in the multi-section cooking.

Example: If you want to use "20 minutes of 100% microwave power + 5 minutes of 80% microwave power" to cook.

- 1) Press "**Microwave**" once, the screen display "P100".

- 2) Press " ▲ " or " ▼ " to choose the cooking time of 20 minutes.

- 3) Keep on pressing "**Microwave**" pad till "P80" is displayed.

- 4) Press " ▲ " or " ▼ " to choose the cooking time of 5 minutes.

- 5) Press "**Start/ +30SEC./ Confirm**" to start cooking.

10. Pre-set Function

- 1) Set the clock first. (Consult the instruction of clock setting.)

- 2) Input the cooking program. Three stages can be set at most. Defrosting should not be set under this function. Please do not press "**Start/ +30SEC./ Confirm**" at the last step.

- 3) Press "**Clock/Pre-Set**", the current time is displayed, and the hour figures will flash.

4) Press " ▲ " or " ▼ " to adjust the hour figures, the input time should be within 0--23(for 24H) or 1--12(for 12H).

5) Press "**Clock/Pre-Set**", the minute figures will flash.

6) Press " ▲ " or " ▼ " to adjust the minute figures, the input time should be within 0--59.

7) Press "**Start/ +30SEC./ Confirm**" to finish setting, and the current time will be displayed, ":" will not flash.

8) Buzzer sounds twice when time arrives. If the door is not closed well, the unit will wait.

Note: 1. Clock must be set first. Otherwise, preset cooking will not work.

2. Auto menu cooking and memory cooking can be set as one stage cooking only, but not multi-section cooking.

11. Auto Reheat

1) Press "**Auto Reheat**" for times to choose the kind of food referred to the auto reheat chart, and "h-1", "h-2", "h-3" or "h-4" will display in cycle for each added press.

2) Press " ▲ " or " ▼ " to choose the weight or portions, and "AUTO", " ☺ " will light.

3) Press "**Start/ +30SEC./ Confirm**" to start cooking, cooking time counts down, and "AUTO" and " ☺ " will flash.

Auto Reheat Chart

Kind	Weight(g)	Display
h-1 Auto Reheat	150	150
	250	250
	350	350
	450	450
	600	600
h-2 Dinner Plate	250	250
	350	350
	450	450
h-3 Beverage/Coffee	1(about 240g)	1
	2(about 480g)	2
	3(about 720)	3
h-4 Roll/Muffin	1(about 70g)	1
	2(about 140g)	2
	3(about 210g)	3

12. Speedy cooking

In waiting state, start operation at 100% microwave power for 30 seconds by pressing the "**Start/ +30SEC./ Confirm**" key. And 30 seconds will be increased by each pressing. The maximum cooking time is 95 minutes.

Note: in defrost, auto menu cooking, and multi-section cooking, time cannot be increased by pressing "**Start/ +30SEC./ Confirm**".

13. Child Lock Function

Lock: Press "**Stop/Clear**" key 3 seconds, after a long "beep". it shows the current time or "0:00", and "  " will be displayed.

Unlock: Press "**Stop/Clear**" key 3 seconds, "  " disappears and machine returns to normal status.

14. Inquiring Function

- (1) In cooking state, press "**Microwave**" or "**Convection/Grill/Combi.**" to check the microwave power or cooking type.
- (2) In pre-set state, press "**Clock/Pre-Set**" to inquire the time for delay start cooking.
- (3) In cooking state, press "**Clock/Pre-Set**" to check the current time.

15. Specification

- (1) Buzzer will sound five times when operation finish;
- (2) "**Start/ +30SEC./ Confirm**" must be pressed to continue cooking if the door is opened during cooking process;
- (3) Once the cooking state has been set, "**Start/ +30SEC./ Confirm**" key is not pressed within 5 minutes, LED displays the current clock, the setting procedure will not work;
- (4) Buzzer sounds once by efficient pressing and no response by inefficient pressing.

InstaCook Menus

For food or the following cooking mode, it is not necessary to program the duration and the cooking power. It is sufficient to indicate the type of food that you wish to cook as well as the weight of this food. The result of Insta cook depends on factors such as the shape and size of food, your personal preference as to the doneness of certain foods and even how well you happen to place the food in the oven. If you find the result at any rate not quite satisfactory, please adjust the cooking time a little bit accordingly.

To set menu cook program, please follow steps bellow:

1. In standby mode, press ▲ to select auto menu.
Then keep press ▼ or ▲ to select food code (see table below)
2. Press “**Start/+30Sec./Confirm**” to confirm the food.
3. Press ▼ or ▲ to select food weight or number of servings.
4. Press “**Start/+30Sec./Confirm**” to start.

InstaCook Food/cooking mode	Notes
Insta1 (g)	<p>1. Weight parameters are used to determine the time needed to do the job. As you press ▼ or ▲, the pre-set weight parameters will be displayed, when it comes up of the right figure which matches the weight of the food you have placed into the oven, press Start.</p> <p>2. InstaCook Recipe mentioned below you will require to decide the ingredients & their quantities as per your taste.</p>
Insta2 (ml)	
Insta3 (g)	
Insta4 (g)	
Insta5 (g)	
Insta6 (g)	
Insta7 (g)	
Insta8 (g)	
Insta9 (g)	
Insta10 (g)	

InstaCook Recipes

INSTA 1

IDLY: - Take idly batter in a suitable lightly greased MWO safe idly maker, Place it on the turn table in the Microwave oven, select Insta1, set weight and press start. Serve hot with chatni & sambaar.

DHOKLA: Take gram flour, curd, water and salt, mix well, cover it and set aside

for 4 hours. Add green chilies & ginger paste, turmeric, lime juice, oil, and soda-bi-carb and mix well until smooth (Quantities as per your taste and requirements). Pour into a lightly greased microwave oven safe bowl, place it on the turn table in the Microwave Oven, select Insta1, set weight and press start. For dressing use curry leaves, mustard seeds, oil, coriander leaves and green chilies.

EGG-BHURJI: - Prepare Tadka in a Microwave oven safe bowl as mentioned under Insta3. Add egg into it and beat well, place the bowl on the turn table in the microwave oven, select Insta1, set weight and press start. Mix well a couple of times in between. Serve Hot.

PEANUT ROAST :-(Masala Peanuts) - Take peanuts in a Microwave Oven safe glass bowl, add water, red chilly powder, salt to taste, mix well and set aside for 15 minutes. Drain out the water; place the glass bowl on the turn table in the Microwave oven. Select Insta1, set weight and press start. Mix once in between. Set aside for some time to cool and serve.

MUSHROOM MASALA: Prepare Tadka as under Insta3 mentioned below. Add Mushrooms, tomato puree, chili powder, salt, water and mix well, place the bowl on the turn table in the Microwave oven. Select Insta1, set weight and press start.

INSTA 2

SABUDANA KICHIDI - Prepare 'Tadka' as mentioned below under Insta3 (use oil, chopped chillies, ground peanut powder and small pieces of potato). Add sabudana (soaked over night), salt, pinch of sugar, few drops of lime juice, mix well, cover it with a lid, place on the turn table in the Microwave Oven, select Insta2, set weight and press start. Serve hot.

POHA: - Prepare 'Tadka' as mentioned below under Insta3. Add washed Poha, pinch of sugar, lime drops, stir well and place on the turn table in Microwave oven and select Insta2, set weight and press start. Garnish with coriander leaves. Serve hot.

OMLETTE: – Take a Microwave oven safe bowl; add oil, cumin, chopped green chillies, Tomato & Onion, salt to taste, add eggs and beat until all ingredients are uniformly mixed. Place the bowl on the

turn table in the Microwave oven. Select Insta2 set weight and press start. Serve hot.

GARAM MASALA ROAST: – Take coriander seeds, cloves, cumin, cinnamon, cardamom, bay leaves, salt (quantities as per your requirement) and mix well. Place the bowl on the turn table in the Microwave oven. Select Insta2, set weight and press start. Remove and set aside to cool. Grind well.

TOMATO SOUP – Take tomatoes (pierced on all sides with a fork for the steam to escape) in a microwave oven safe bowl, select Insta2, set weight and press start. Once done remove and set aside for 10 minutes, peel off the skin, take into a juicer jar, add water, masala powder to taste and grind well.

INSTA 3

TADKA: – Take oil, Chopped onion & chillies, cumin, mustard, Turmeric powder, salt, garam masala in a microwave oven safe bowl (Quantities & ingredients as per your requirement & taste) mix well, select Insta3, set weight and press start.

PANEER BHURJI: Prepare 'Tadka' in a Microwave Oven safe bowl as mentioned above in Insta3. Add grated Panner and tomato puree into it mix well and place the bowl on the turn table in a Microwave oven, select Insta3, set weight and press start. Garnish with grated cheese and coriander leaves. Serve Hot.

PRAWN CURRY: Prepare 'Tadka' in a Microwave Oven safe bowl as mentioned above in Insta3. Add Prawns, curd, water, stir well, place on the turn table in the Microwave oven, select Insta3, set weight and press start. Serve Hot

GREEN PEAS MASALA - Prepare Tadka under Insta3. Add green peas, tomato puree, mix well, place the bowl on the turn

table in the microwave oven, select Insta3, set weight and press start. Serve hot.

LEAFY VEGETABLES: – Prepare 'Tadka' in a Microwave Oven Safe Bowl as mentioned above under Insta3. Now add leafy vegetables into it, stir well and place it on the turn table in a Microwave oven select Insta3, set weight and press start. Serve hot.

INSTA 4

BREAD BROWNING: Apply butter to the both sides of bread slices. Arrange bread slices on the high grill rack placed on the turn table in the microwave oven, select Insta4, set weight and press start.

GRILLED PAPAD: Arrange Papads on the high grill rack, place the rack on the turn table in microwave oven, select Insta4 set weight and press start.

CASHEW /BADAM ROAST: Take ghee in a Microwave Oven safe bowl; add salt and cashew/ Badam. Mix all ingredients well and place on the turn table in the microwave oven. Select Insta4 set weight and press start. For the better perfection Mix twice in between.

BUTTER MELTING: – Take butter in a glass bowl and Place the bowl on high grill rack, Select Insta4, enter weight and press start.

INSTA 5

PIZZA:– Take a pizza base and coat with butter, grated cheese, and top with vegetables like cabbage, capsicum, tomato ketchup, grated cheese, mushrooms etc Arrange pizza base on the high metal grill rack, place it on the turn table in the oven, select Insta5, set weight and press start.

For non-veg pizza, use non-veg toppings as per your choice and taste.

FISH ROAST: - Marinate the cleaned fish with a mixture of butter (oil), garlic ginger paste, red chilly powder, salt, thick cream, (all as per your taste and requirement) and set aside for 2 hr. Toss marinade fish in bread crumbs or suji and arrange the fish on a high grill rack, place it on the turntable in the oven, select Insta5, set the weight and press start.

LOBSTER ROAST: – Marinate the cleaned Lobsters with a mixture of oil, red chili powder, lime juice, ginger garlic onion paste, salt, coconut milk (all as per your taste and requirement) and set aside for 2 hrs. Arrange the marinated lobsters in a high grill rack, place it on the turn table in the oven, select Insta5, set the weight and press start. For better result turn once.

CRABS ROAST: – Marinate the cleaned with a mixture of oil, red chili powder, lime juice, ginger garlic onion paste, salt, coconut milk (all as per your taste and requirement) and set aside for 1½ hrs. Arrange the marinated crabs in a high grill rack, place it on the turn table in the oven, select Insta5, set the weight and press start.

PRAWNS ROAST: – Marinate skinned and deveined king prawns with a mixture of Butter, lime juice, ginger onion paste, red chili powder, salt (all as per your taste and requirement) and set aside for 1 hr. Arrange the king Prawns on a high grill rack, Place it on the turn table in the oven, select Insta5, select weight and press start. For better result turn once while grilling.

INSTA 6

CAKE:-To make Cake batter use flour, ground sugar, baking powder, butter, condensed milk, cocoa powder, vanilla essence (all as per your taste and requirement), mix well and blend all ingredients until smooth. Pour the smooth batter into a lightly greased glass/steel/aluminum utensil and place it

on the turn table in the oven, select Insta6, and press start.

COOKIES:- To make cookies use flour (Maida), ground sugar, butter, cocoa powder, essence, baking soda, dry fruits, (all as per your taste and requirement) mix all ingredients to make dough. Shape the dough into small shapes as required; place it on lightly greased high grill rack on the turn table in the oven, select Insta6, and press start.

HONEY GARLIC, GINGER WHOLE CHICKEN:- Marinate the whole chicken with the mixture of Garlic ginger paste, oil, soya sauce, vanilla, honey, grounded cinnamon, mustard and set aside for 2 hours. Arrange the chicken on a low grill rack; place it on the turn table inside the Oven, select Insta6, and press start. For better result turn once while grilling.

MUTTON MINCE BALLS: – Take mutton mince, add egg, bread crumbs, garlic onion paste, milk, oil, tomato sauce, sugar, mustard, salt and pepper (all as per your taste and requirement). Mix all ingredients and blend with a blender or in a mixer. Make small or required size balls of this mix, arrange them on a high grill rack/ crispy plate, and place it on the turn table inside the oven. Select Insta6 and press start. For better result turn once while grilling.

DAL BHATI: –To make the dough for the bhati, use flour (Maida), ghee, ajwain, water, suji and salt (all as per your requirement and taste). Make small balls of the Dough; arrange them on the metal turn table or crispy plate in the microwave oven, select Insta6, and press start.

INSTA 7

PASTA/ MACARONI: - Take a microwave oven safe bowl, add pasta/ Macaroni, chopped tomatoes, onions, cumin, red chili powder, salt, pepper (all as per your requirement and taste), and water and mix

well. Place the bowl on the turn table in the Microwave oven and select Insta7, set weight and press start.

VEGETABLE PULAO:- Prepare Tadka as mentioned under Insta3. Add rice, chopped vegetable, water and mix well. Place the bowl on the turn table in the Microwave oven, select Insta7, set weight and press Start.

DAL TADKA: – Prepare Tadka as mentioned under Insta3, mentioned above. Add Dal and water. Place it on the turn table in the microwave oven, select Insta7, set weight and press start

KHEER: Take rice in a microwave oven safe bowl; add milk, sugar and mix well. Place the bowl on the turn table in the microwave oven, select Insta7, set weight and press start. For the better result stir twice and add condensed milk, raisins, cashew, almonds or pista. Garnish with finely powdered cardamom.

CHANNA MASALA:-Take a microwave oven safe bowl, add oil, chopped onion, chopped tomato, chopped green chili, Garlic Ginger paste, bay leaves, cinnamon, turmeric powder, salt, garam masala (all as per your requirement and taste), mix well and Prepare Tadka as mentioned under Insta7, mentioned above. Add Channa, water, stir and select Insta7, set weight and press start.

INSTA 8

VEGETABLE KABABS: – Marinate vegetable pieces with a mixture of red chilly powder, garlic, salt, pepper and thick cream (all as per your taste and requirement). Set aside for 1 hrs. Arrange the vegetable pieces on the rotisserie Skewers, press Insta8, select B1 and press start.

CHICKEN TANDOOR: – Marinate chicken with a mixture of curd, thick cream, oil, corn flour, red chilly powder, garam

masala, ginger garlic paste, orange color (optional), lime juice and salt (all as per your taste and requirements). Set aside for 2 hours. Arrange the tandoori chicken on a low grill rack, place it on the turn table in the microwave oven, press Insta8, select B2 and press start.

MUTTON ROAST: Grind Chili powder, Black pepper, Cloves, Ginger, Coriander powder and a little water into a smooth paste. Clean and cut the meat into small pieces. Apply the ground paste to the meat pieces along with the curd and keep it aside for 4 to 5 hrs to marinate. Grease a baking tray, put the meat pieces in it and pour melted Ghee / butter over it. Place the baking tray on the turn table in the microwave oven, press Insta8; select B3, press start.

BAKED FISH: – Take butter (oil) in a mixing bowl, add Tomato sauce, and salt, pepper (all as per your taste and requirements) and mix well. Add bread crumbs and mix again. Toss the fish pieces in it and place it on a lightly greased metal backing tray. Place it on the turn table in a microwave oven, press Insta8, select B4, press start.

CHICKEN KABABS: – Marinate Chicken pieces with a mixture of red chilly powder, garlic, salt, pepper and thick cream (all as per your taste and requirement). Set aside for 2 hrs. Arrange the Chicken pieces on the low grill rack, place the rack on the turn table in the oven, press Insta8, select B5 and press start.

CHICKEN TIKKA: – Marinate Chicken with a mixture of curd, cumin, thick cream, oil, corn flour, red chilly powder, garam masala, ginger garlic paste, limes juice and salt (all as per your taste and requirement). Set aside for 2 hours. Take a microwave oven safe bowl, add oil, chopped onion, and chopped capsicum, chopped tomato and add the marinated chicken and mix well. Place the bowl in the microwave oven, press Insta8, select

B6, and press start. Mix a couple of times in between.

INSTA 9

CORN CHAT: – Take corn in a microwave oven safe bowl, add chat masala as per taste, select Insta9, set the weight and press start.

VEG/ CHICKEN STOCK: - Take chopped vegetables / chicken in microwave oven safe bowl add 1 cup of water mix well, select Insta9 mode , set the weight and press start. Collect the boiled water (stock) in another bowl.

RAVA (SUJI) ROAST: – Take suji (rawa) in a paper envelop, place it on the turn table, select Insta9, set the weight and press start. For better result stir twice while roasting.

HOT CHOCOLATE:- Take milk in a microwave oven safe glass, add cocoa powder, stir well, place in Microwave oven, select Insta9, set the weight and press start. Serve Hot

SHEERA (SUJI KA HALWA): Roast Suji (Rawa) as mentioned in Insta9. Take the roasted Suji in a microwave oven safe bowl add sugar, water, ghee, cardamom powder, raisins, Cashew nuts, almonds into it, stir and cook in Insta9 mode, set the weight and press start. Serve hot.

INSTA 10

MIX VEGETABLES: Prepare Tadka in a Microwave safe bowl as mentioned under Insta3 above. Add potato, mushrooms, green peas, carrot, baby corns, broccoli, water and mix well. Place the bowl on the turn table in a microwave oven, select Insta10, set weight and press start.

UPMA: Prepare Tadka in a Microwave safe bowl as mentioned under Insta3. (Add groundnuts, channa dhal, urad dhal,

tomato, carrot, green peas, salt as per taste and requirement before preparing the tadka) Add roasted rava, water, mix well, select Insta10, set weight and press start.

Garnish with grated coconut & green coriander. Serve hot.

NOODLES: Take oil in a microwave oven safe bowl, add onion, tomatoes, carrots, beans, cabbage, red chili powder, turmeric powder, soya sauce, chilly flakes, and salt, stir all ingredients well, add soaked noodles, noodles masala, chopped capsicum, coriander leaves, mix well and place in on the turn table in the microwave oven. Select Insta10, set weight and press start.

FISH CURRY: Marinate the fish in salt and turmeric powder for 15 minutes. Take oil in a microwave oven safe bowl; add marinated fish in it and prepare Tadka in a

microwave safe bowl as mentioned under Insta3. Add the marinated fish. Add paste of Grinded coriander leaves, garlic and green chillies. Add tomatoes, powder masalas, and water, mix slowly and place the bowl on the turn table in the microwave oven. Select Insta10, set weight and press start.

PALAK PANEER: Grind the Spinach leaves with water till it turns into a smooth thick paste. Prepare Tadka as mentioned under Insta3 above. Add butter, pannier cubes, bay leave, kasoori methi, salt, spinach ground paste, milk, sugar, and stir all smoothly. Place the bowl on the turn table in the microwave oven, select Insta10, set weight and press start. Garnish with thick cream.

CLEANING AND CARE

1. Turn off the oven and remove the power plug from the wall socket before cleaning.
2. Keep the inside of the oven clean. When food splatters or spilled liquids adhere to oven walls, wipe with a damp cloth. Mild detergent may be used if the oven gets very dirty. Avoid the use of spray and other harsh cleaners as they may stain, streak or dull the door surface.
3. The outside surfaces should be cleaned with a damp cloth. To prevent damage to the operating parts inside the oven, water should not be allowed to seep into the ventilation openings.
4. Wipe the door and window on both sides, the door seals and adjacent parts frequently with a damp cloth to remove any spills or spatters. Do not use abrasive cleaner.
5. Do not allow the control panel to become wet. Clean with a soft, damp cloth. When cleaning the control panel, leave oven door open to prevent oven from accidentally turning on.
6. If steam accumulates inside or around the outside of the oven door, wipe with a soft cloth. This may occur when the microwave oven is operated under high humidity condition. And it is normal.
7. It is occasionally necessary to remove the glass tray for cleaning. Wash the tray in warm sudsy water or in a dishwasher.
8. The roller ring and oven floor should be cleaned regularly to avoid excessive noise. Simply wipe the bottom surface of the oven with mild detergent. The roller ring may be washed in mild sudsy water or dishwasher. When removing the roller ring from cavity floor for cleaning, be sure to replace in the proper position.
9. Remove odors from your oven by combining a cup of water with the juice and skin of one lemon in a deep microwaveable bowl, microwave for 5 minutes. Wipe thoroughly and dry with a soft cloth.
10. When it becomes necessary to replace the oven light, please consult a dealer to have it replaced.
11. The oven should be cleaned regularly and any food deposits removed. Failure to maintain the oven in a clean condition could lead to deterioration of the surface that could adversely affect the life of the appliance and possibly result in a hazardous situation.
12. Please do not dispose this appliance into the domestic rubbish bin; it should be disposed to the particular disposal center provided by the municipalities.

TROUBLE SHOOTING

Before calling for service check the following list to be sure that a service call is necessary. Reviewing additional information on items in the following table may prevent an unneeded service call

PROBLEM	POSSIBLE CAUSES
If nothing on the oven operates	<ul style="list-style-type: none"> - Check for a blown circuit fuse or a tripped main circuit breaker. - Check if oven is properly connected to the electric circuit in house. - Check if controls are set properly
If the oven interior light does not work	<ul style="list-style-type: none"> - The light bulb is loose or defective
If oven does not cook	<ul style="list-style-type: none"> - Check that the control panel was programmed correctly - Check that the door is firmly closed - Check that Start/Enter pad was touched
If over takes longer that normal to cook or cooks too rapidly	<ul style="list-style-type: none"> - Be sure the power level is programmed properly
If the time of the day clock does not always keep the correct time	<ul style="list-style-type: none"> - Check that the power cord is fully inserted into the power outlet - Be sure the oven is the only appliance in the electrical circuit
If food cooks unevenly	<ul style="list-style-type: none"> - Be sure that the food is evenly placed - Be sure that the food is completely defrosted before cooking - Check placement of aluminum foil strips used to prevent over cooking
If food is under cooked	<ul style="list-style-type: none"> - Check recipe to be sure all directions (amount, time and power levels) were correctly followed - Be sure the oven is the only appliance in the electrical circuit - Be sure that the food is completely defrosted before cooking
If food is over cooked	<ul style="list-style-type: none"> - Check recipe to be sure all directions (amount, time power levels & size of dish) were correctly followed
If arcing (sparks) occur	<ul style="list-style-type: none"> - Be sure microwavable dishes were used. - Be sure wire-twist ties were not used - Be sure that the over was not operated when empty - Be sure that metal racks is not used in the microwave mode

FREQUENTLY ASKED QUESTIONS

QUESTION	ANSWER
Can I use a rack in my microwave oven so that I may reheat or cook in two rack positions at a time	Only use the rack that is supplied with your microwave oven. Use of any other rack can result in poor cooking performance and/or arcing and may damage your oven.
Can I use either metal or aluminum pans in my microwave oven?	Usable metal includes aluminum foil for shielding (use small, flat pieces). Never allow metal to touch the walls or door
Sometimes the door of my microwave oven appears wavy. Is this normal?	This appearance is normal and does not affect the operation of your oven.
What are the humming noises I hear when my microwave oven is operating?	This is the sound of the transformer when the magnetron tube cycles on and off.
Why does the dish become hot when I microwave food in it?	As the food becomes hot, it will conduct the heat to the dish. Use hot pads to remove food after cooking. The dish may not be microwave safe.
What does standing time mean?	Standing time means that food should be left in the oven for a short period of time after the cooking is over which allows the cooking to finish
Can I pop popcorn in my microwave oven? How do I get the best results?	Yes. Pop packaged microwave popcorn following manufactures guideline or use the pre programmed popcorn pad. Do not use regular paper bags Use the listening test by stopping the oven as soon as the popping slows to a pop every 1 to 2 secs. Do not try to repop unpopped kernels. Do not pop popcorn in glass utensils
Why does steam come out of the air exhaust vent?	Steam is normally produced during cooking. The microwave oven has been designed to vent this steam out the top vent.

MICROWAVE OVEN WARRANTY

The Godrej Microwave Oven comes with a THREE years warranty on the magnetron and a ONE year warranty (except for plastic parts, glass components and decorative strips, knobs etc.) against defective material or workmanship on all components of the microwave oven. Godrej & Boyce Mfg. Co. Ltd. Appliance Division undertakes repairs, free of charge during the warranty period.

INSTRUCTIONS FOR THE CUSTOMER

1. Kindly ensure that the dealer fills the warranty details correctly and completely.
2. You should retain the warranty page for record and produce the same in the event of any warranty repairs.
3. In the event of a defect developing in the product, contact the nearest authorized Godrej & Boyce Service Centre for obtaining warranty service and inform the defect, model details and Serial No.

TERMS AND CONDITIONS

1. Repairs and replacement of parts will be carried out through the authorized customer service centre.
2. For units installed beyond the municipal limits of the jurisdiction of the authorized customer care centre all expenses incurred in collecting the units or parts thereof from the company's customer care centre, as well as expenses incurred with depositing of service personnel / technician's towards conveyance and other incidents will be borne by the customer.
3. The concerned customer care centre will advise the customer whether to effect the repair at site or at the customer care centre.
4. While the company will make every effort to carry out the repairs at the earliest, it however is made expressly clear that the company is under no obligation to do so in a specified period of time.
5. The company or its authorised customer care centre / service dealer reserves the right to retain any parts, components replaced at its discretion.
6. Warranty does not cover accessories to the equipment.
7. The warranty is confined to the first purchaser of MWO only and non-transferable.
8. Call registered with the centralized helpline / authorized service centre, where in only cleaning of the unit/ parts in the unit due to dust accumulation on portions of the units are not to be considered as defects.
9. **In case of any damages to the product, customer abuse, repairs by unauthorized personnel & misuse detected by the authorized service centre personnel, the warranty conditions are not applicable.**
10. If any coloured internal or external components are replaced, effort will be made to ensure that the shades match with the original or other components. However, the replaced shades, pattern, tints may vary from the customer's unit due to usage of the unit. Any matching components changed at customer's request will be charged, except the component which is actually needed.
11. **The unit shall be operated with variation +/-5% of the rated voltage. Fluctuation beyond specified tolerance will not be covered under warranty. Customer shall not operate the product below 210V under any circumstances.**
12. Parts not covered - Main door, Glass, Bulb, Rubber, Plastic Components.
13. This warranty does not cover any type of painting, plating including rusting etc. or defects thereof.
14. **The product must be maintained to keep hygiene. Any insects, rodents their causing obstruction to functioning the product, company is not responsible and in turn warranty stands terminated.**

Godrej & Boyce Mfg. Co. Ltd.- Appliance Division

WARRANTY DETAILS

MODEL NO.
UNIT SR. NO.

DATE OF PURCHASE

CUSTOMER'S NAME & ADDRESS

TEL. _____

DEALER'S NAME & ADDRESS

TEL. _____

Customer's Signature:

Dealer's Signature:

This card is valid only if it is filled in and stamped by our authorised dealer on the date of purchase.

Warranty is Void If:

1. The warranty card is not completed properly at the time of purchase.
2. The completed warranty card is not presented to the authorized personnel at the time of service of the product.
3. The microwave is not operated according to instructions given in the 'User Guide'.
4. Defects are caused by improper or reckless use, which shall be determined by the company personnel.
5. Any repair work carried out by persons other than authorised company personnel.
6. Defects caused beyond control like abnormal voltage, acts of God, or while in transit to service center or purchaser's residence.
7. The warranty is not valid in case the serial number is deleted, defaced or altered.
8. Damage to the microwave or any parts due to transportation or shifting is not covered by the warranty.
9. The warranty automatically expires after 12 month of original date of purchase, even if the microwave may not be in use for any time for whatever reasons during the warranty period.

SERVICE CENTRES

For any further assistance, please contact our call centre or the nearest branch office:

BRANCH	ADDRESS
Ahmedabad (Branch)	4th Floor, APM Shopping Mall, Near IOCL Petrol Pump, Shyamal-Karnavati, 100 Ft. Road, Satellite, Ahmedabad - 380 015.
Bangalore (Branch)	3rd Floor, The Karnataka Film Chamber of Commerce Bldg, 28, 1st Main, Crescent Road, High Grounds, Near Shivanand Circle, Bangalore - 560 001.
Bhopal (Branch)	217, Zone I, M.P. Nagar, Behind Jyoti Talkies, Bhopal - 462 011.
Bhubaneswar (Branch)	Highway Complex, NH-5, Rudrapur, Bhubaneswar - 752 101.
Chandigarh / Mohali (Branch)	Plot No. A-40, Phase-VIII-A, Industrial Area, Mohali, Punjab - 160 059.
Chennai (Branch)	No.1, Sidco Industrial Estate, Ambattur, Chennai - 600 098.
Coimbatore (Branch)	1st Floor, Gowtham Arcade, T.V. Samy Road East, R.S. Puram, Coimbatore - 641 002.
Delhi (Branch)	Godrej Bhavan, 2nd Floor, Shershah Suri Marg, Okhla, New Delhi - 110 065.
Faridabad (Branch)	Godrej Bhavan, 2nd Floor, Shershah Suri Marg, Okhla, New Delhi - 110 065.
Ghaziabad (Branch)	Godrej Bhavan, 2nd Floor, Shershah Suri Marg, Okhla, New Delhi - 110 065.
Goa Service Centre	Shed A-1, Corlim Industrial Estate, Opp. Telephone Exchange Corlim, Goa - 403 110.
Guwahati (Branch)	Godrej Building, G.S. Road, Ullubari, Flyover, Guwahati - 781 007.
Hyderabad (Branch)	201 & 202, Lala-1 Land Mark, 5-4-94 to 97, 2nd Floor, Above Digital Shoppy, Ranigunj, M.G. Road, Secunderabad - 500 003.
Jaipur (Branch)	502-506, 5th Floor, Gaurav Towers, Malviya Nagar, Jaipur - 302 017.
Kochi (Branch)	Near Info Park, Edachira, Thengode P.O., Kakkanad, Kochi - 682 030.
Kolkata (Branch)	Block GN, Sector V, Salt lake, Kolkata - 700 091.
Lucknow (Branch)	C 3/3 & C3/4, Sanjay Complex, Behind Akashwani Bhawan, Vidhan Sabha Marg, Lucknow.
Mumbai (Branch)	Appliance Divn., Plant 4, Pirojshanagar, Vikhroli, Mumbai - 400 079.
Patna (Branch)	Jeevan Deep Building, Exhibition Road, Patna - 800 001.
Pune (Branch)	Saraswati Sadan, 229/230, M.G. Road, Pune - 411 001.
Ranchi (Branch)	C/o. Surya Motors, Pandra, Ranchi, Jharkhand.

Call Centre

186030002030

(Reliance & other service providers)

/

Toll Free No.

1800225511

(MTNL/BSNL)

/

18002095511

(TATA & Other service providers)

SMS

<godrej><space><care>

to

53636

to receive
a call back
from our
call centre.

Website: www.godrejsmartcare.com | www.godrejappliances.com

E-mail: smartcare@godrej.com

Godrej eon[®]